

Conductive conductivity/ultra-pure water sensors  
with a 2-electrode system,  
types 202922, 202923, 202924, 202925  
Glass conductivity sensors, type 202922/30  
Diaphragm tubes, type 201083  
Compensation thermometer, type 201085  
N cable socket, type 202990

**B202900.01**  
Operating Manual



### **Warning**

A sudden sensor malfunction could potentially result in dangerous and imprecise dosing! Suitable preventive measures must be in place to prevent this from happening.



### **Note**

Please read these operating instructions before putting the instrument into operation. Keep the manual in a place which is accessible to all users at all times. All the necessary settings are described in these operating instructions. If any difficulties should nevertheless arise during startup, please do not tamper with the instrument in any way. By doing so, you could endanger your rights under the instrument warranty! Please contact your supplier.



### **Note**

Conductive conductivity sensors are not authorized for use in highly adherent, oily or glutinous media – we recommend using our inductive conductivity measuring instruments here!



### **Note**

A flat-rate charge of EUR 35 will be made if we receive instruments without a description of their fault. This fee will be added to the possible cost of repair.

|          |   |           |
|----------|---|-----------|
| <b>1</b> | <b>Conductive conductivity/ultra-pure water sensors with a 2-electrode system, types 202922, 202923, 202924, 202925 .....</b> | <b>5</b>  |
| 1.1      | Application .....   | 5         |
| 1.2      | Principle of measurement .....  | 5         |
| 1.3      | Measuring cells for laboratory and industrial use .....   | 5         |
| 1.4      | Measuring ranges .....  | 6         |
| 1.5      | Electrical connection .....   | 7         |
| 1.6      | Installation .....  | 8         |
| 1.7      | Maintenance/cleaning .....  | 9         |
| 1.8      | Troubleshooting .....   | 10        |
| 1.9      | Screwing the conductivity sensor into the fitting .....   | 11        |
| <b>2</b> | <b>Glass conductivity sensors, type 202922/30 .....</b>   | <b>12</b> |
| 2.1      | Application .....   | 12        |
| 2.2      | Technical data .....  | 12        |
| 2.3      | Mounting .....  | 13        |
| 2.4      | Maintenance .....   | 13        |
| 2.5      | Storage .....   | 13        |
| <b>3</b> | <b>Diaphragm tubes, type 201083 .....</b>   | <b>14</b> |
| 3.1      | Application .....   | 14        |
| 3.2      | Technical data .....  | 14        |
| 3.3      | Mounting .....  | 15        |
| 3.4      | Maintenance .....   | 16        |
| <b>4</b> | <b>Compensation thermometers, type 201085 .....</b>   | <b>17</b> |
| 4.1      | Application .....   | 17        |
| 4.2      | Technical data .....  | 17        |
| 4.3      | Mounting .....  | 18        |
| <b>5</b> | <b>N cable socket, type 201090 .....</b>  | <b>21</b> |
| 5.1      | Application .....   | 21        |
| 5.2      | Mounting .....  | 22        |

---

# Content

---

---

---

# **1 Conductive conductivity/ultra-pure water sensors with a 2-electrode system, types 202922, 202923, 202924, 202925**

## **1.1 Application**

Conductive conductivity sensors are used in conjunction with suitable transmitters in industrial analysis measurement technology to determine the electrolytic conductivity of liquid media (or the resistance, in the case of ultra-pure water).

## **1.2 Principle of measurement**

Two conductive electrodes of a defined area are immersed in the sample medium, a specific distance apart. An AC voltage of a specific measurement frequency (subject to the measuring range), is supplied to the electrodes by a separate transmitter. The conductive components (ions, salts) contained in the sample medium cause an alternating current to appear between the electrodes, which the transmitter uses to determine and display the conductivity, and convert it to a standard signal.

## **1.3 Measuring cells for laboratory and industrial use**

Conductivity cells consists of a plastic or stainless steel flow-through, immersion or screw-in body and the embedded electrodes. Depending on the type, application and measuring range, the two electrodes are made from materials such as stainless steel, titanium, platinum or special-purpose graphite.

The conductivity sensors come from the manufacturer with a fixed cell constant,  $K$  [1/cm].

Typical cell constants include:  $K = 0.01/0.1$  or  $1.0$ . Intermediate values are possible for customized versions.

The downstream transmitter must be set to the cell constant of the measuring cell. Additional temperature sensors can be installed in the measuring cells, subject to the particular application.

---

## 1.4 Measuring ranges

The measuring range of conductive conductivity sensors is physically restricted to max. 15 mS/cm.

The measuring ranges are roughly divided up according to cell constants, in the table below.



### Note

The actual measuring range limits will vary, depending on the electrode material, the design and the downstream transmitter!

| Cell constant K [1/cm] | Max. measuring range                                     |
|------------------------|--|
| 0.01                   | up to 5 $\mu\text{S/cm}$ or 20 $\text{M}\Omega\text{cm}$ |
| 0.01                   | up to 10 $\mu\text{S/cm}$                                |
| 0.1                    | up to 3000 $\mu\text{S/cm}$                              |
| 1.0                    | up to 15 $\text{mS/cm}$                                  |

---

## 1.5 Electrical connection

The measuring cells come with an attached cable or with a detachable plug connector, depending on the version.

---



### Caution

The connecting cable must not be routed via the terminal blocks, but must run directly to the transmitter. Use shielded cables only, and if possible, those that are recommended/supplied by the manufacturer.

Follow the instructions in the transmitter operating manual for electrical connection!

---

| Connection for           | Angled connector | Attached cable | M12 connector |
|--------------------------|------------------|----------------|---------------|
| Outer electrode          |                  | white          | 1             |
| Inner electrode          | 2                | brown          | 2             |
| Temperature compensation | 1                | yellow         | 3             |
|                          | 3                | green          | 4             |
| 3-wire circuit           | -                | -              | 5             |
| Shield                   | -                |                | -             |

---

## 1.6 Installation



### Caution

Please heed the technical data for your sensor (see data sheets 202922, 202923, 202924 and 202925). The sensor must be suitable for the temperature, pressure and medium conditions specified for the system (including chemical resistance).

Do not make any mechanical modifications to the sensor (electrodes shortened, drilled, bent or scratched). This can result in the loss of proper functionality, as well as the rights under the instrument warranty.

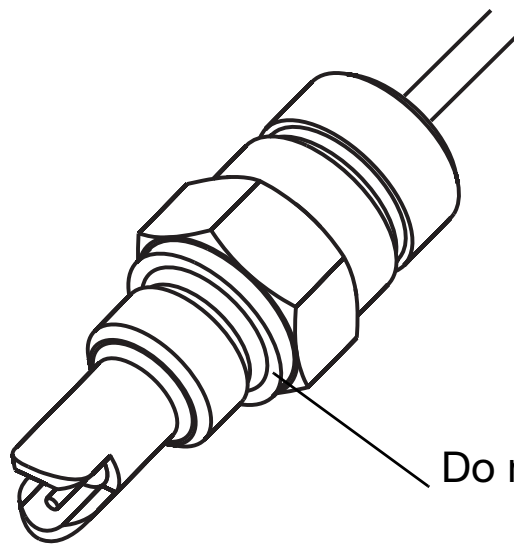

Do not use a metal seal!



### Note

Basically any installation position is possible. However, you must ensure that sufficient sample medium flows through and around the sensor (that is, the conductive sensor electrodes must always be completely surrounded by the medium). Structural measures must be taken to prevent flow separation or gas bubbles.

---

## 1.7 Maintenance/cleaning

The conductive conductivity sensor electrodes are in direct contact with the sample medium. **Regular cleaning must therefore be performed, relative to the susceptibility of the medium to contamination!**

All suitable, common household cleaning chemicals can be used for cleaning. Abrasive cleaners have limited suitability! The measurement electrodes must not be damaged mechanically! Dilute hydrochloric acid, or cleaning in ultrasonic baths, can be helpful to prevent various accumulations, for example.

---

## 1.8 Troubleshooting

Troubleshooting must always consider all the components of the conductivity measurement chain!

The transmitter and the connecting cable must be checked, as well as the sensor.

| <b>Error</b>  | <b>Possible cause</b>   | <b>Remedy</b>   |
|---|---|---|
| Measurement value is too high or too low                                | Sensor is dirty   | Section 1.7 „Maintenance/cleaning“, Seite 9   |
| No conductivity measurement (e.g. display shows "0")                    | Broken lead, incorrect terminal assignment<br>Sensor exposed to air (not fully immersed)                        | Carefully check the electrical connection again!<br>Check the sensor installation location: is liquid medium present?               |
| No temperature measurement (sensors with integrated temperature sensor) | Broken lead, incorrect electrical connection  | Carefully check the electrical connection again!  |
| Display value unstable, fluctuating                                     | Malfunction caused by incorrectly/insufficiently shielded connecting cable<br>Malfunction caused by gas bubbles | Check the cable connection and routing<br><br>Check the installation location and position of the sensor and modify where necessary |



### Note

The sensor can also be checked for short-circuits or internal contact problems. You need a continuity tester (such as the diode tester of a multimeter) to do this.

---

## 1.9 Screwing the conductivity sensor into the fitting

- \* Loosen the cable gland (1).
- \* Run the connecting cable (3) of the conductivity sensor (4) through the fitting (2).
- \* Screw the conductivity cell (4) into the fitting (2).  
Tightening torque approx. 2.5 Nm.
- \* Tighten the cable gland (1).  
Tightening torque approx. 2 Nm.



### Caution

When removing the conductivity sensor from the fitting:  
First loosen the cable gland (1)!

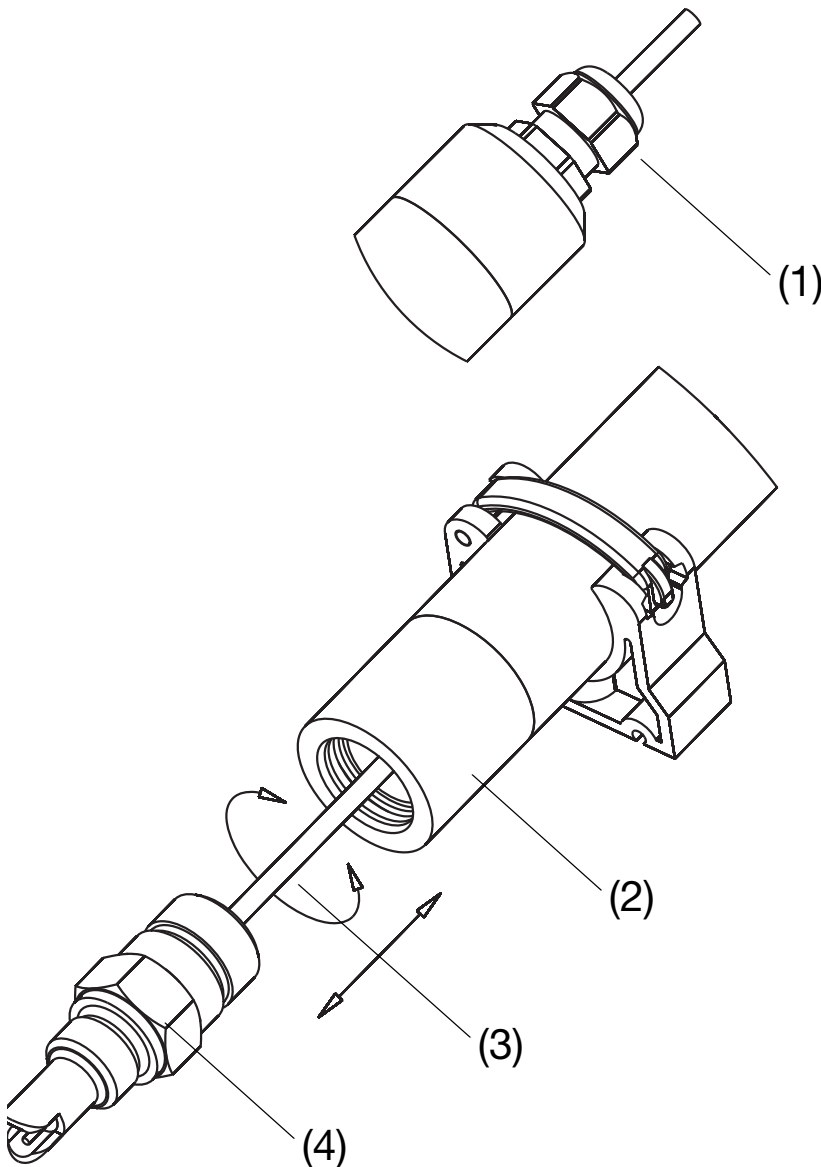

---

## 2 Glass conductivity sensors, type 202922/30

### 2.1 Application

With type 202922/30 glass conductivity sensors, the conductivity of liquids can be determined in conjunction with a conductivity transmitter.

The parts of the sensor that come into contact with the sample medium are composed of glass and platinum. This ensures extensive resistance to aggressive media. The active component (the platinum electrode) can be platinized for use at higher conductivities.

The connections must be kept perfectly clean and dry, to avoid creep currents. During assembly work with coaxial cables, make sure that the black, semi-conducting layer between the braided shield and the inner insulation is removed.

All instruments and components are carefully checked before leaving the factory. Should you nevertheless have cause for complaint, please send the device back to us, free of harmful contamination. Checking returned goods is extremely complicated. It is therefore essential for you to provide more detailed information about the fault.

### 2.2 Technical data

|                                |                        |
|--------------------------------|------------------------|
| Active component               | Platinum               |
| Measuring range, unplatinized  | up to 1 mS/cm          |
| Measuring range, platinized    | up to 100 mS/cm        |
| Cell constant                  | $k = 1 \pm 10 \%$      |
| Permissible medium temperature | -10 to +160 °C         |
| Stem length                    | 120 mm                 |
| Stem diameter                  | 12 mm                  |
| Permissible pressure           | 0 to 6 bar<br>at 25 °C |
| Connection                     |                        |

|   |                             |
|---|-----------------------------|
| • Type 202922/30-0100-xx-xxx-21-x-xxx/xxx | N plug cap                  |
| • Type 202922/30-0100-xx-xxx-22-x-xxx/xxx | N screw plug cap<br>Pg 13,5 |
| • Type 202922/30-0100-xx-xxx-83-x-xxx/xxx | M12 connector               |
| Temperature compensation                  | Pt100                       |

## 2.3 Mounting

Glass conductivity sensors are protected by a protective cap during delivery. This protective cap must be removed before it can be used.

Please follow the selection table for conductivity sensors.

## 2.4 Maintenance

Dirty platinum electrodes can be cleaned by rinsing them in lye. Carefully remove stubborn deposits with a soft brush.

To minimize polarization errors at high conductivities, platinized conductivity sensors (recognizable by their blackened platinum surfaces) can be re-platinized. Re-platinizing takes place galvanically.

## 2.5 Storage

The platinum-plated sensors are vulnerable to drying out and mechanical damage. They should therefore be kept in a watering cap filled with distilled water.

---

### 3 Diaphragm tubes, type 201083

---



#### Note

Diaphragm tubes come with three replacement diaphragms.

---

#### 3.1 Application

Diaphragm tubes are used in conjunction with reference electrodes in a KCl storage vessel, as a reference system, whenever an increased electrolyte flow rate into the sample medium is required, e.g. in emulsions, varnishes and paints.

An electrolyte bridge can be formed in conjunction with a KCl storage vessel, which is connected to the diaphragm tube by a hose. Electrolyte bridges are used if the sample medium poisons the reference system, e.g. media containing sulphides and photographic chemicals.

#### 3.2 Technical data

|   |  |
|---|--|
| Material, Sales no. 00084582                  | PP   |
| permis. medium temperature                    | -10 to +95 °C  |
| permis. pressure<br>(with KCl storage vessel) | 0 to 10 bar t 25 °C  |
| Diaphragm                                     | PTFE, Ø 5 mm   |
| Stem length                                   | 120 mm   |
| Stem diameter                                 | 12 mm  |
| Connection                                    | Crimp connection for<br>PU plastic hose<br>8 mm × 6 mm Ø<br>(pressure-resistant) |

---

### 3.3 Mounting

#### 3.3.1 Screw in the diaphragm tube

The diaphragm tube can be screwed into a Pg 13.5 receiving thread; max. tightening torque 10 Nm.

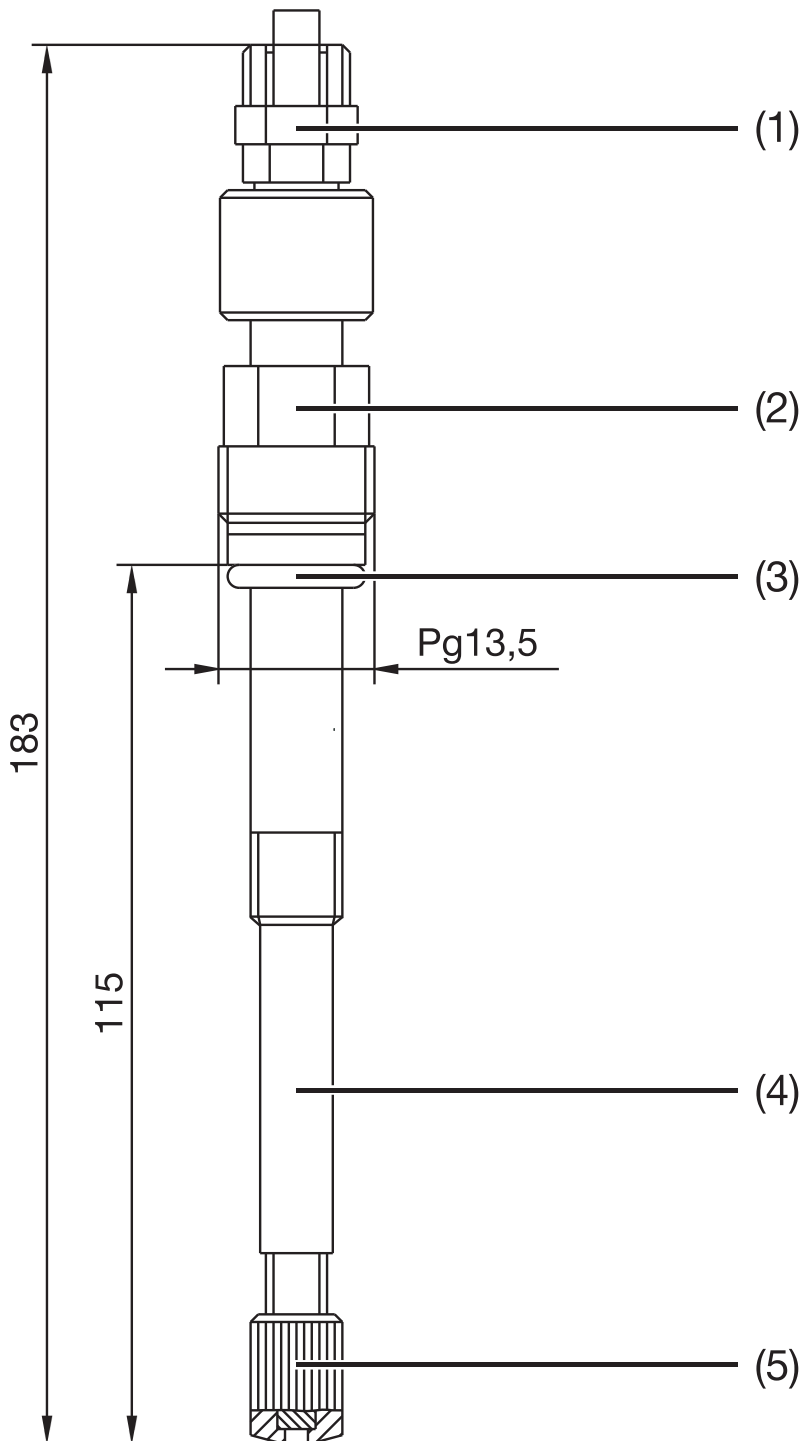

- |     |                                 |     |                |
|-----|---------------------------------|-----|----------------|
| (1) | Plastic screw-connection R 1/8" | (2) | Set screw      |
| (3) | O-ring 10 × 3.5 FPM             | (4) | Diaphragm tube |
| (5) | PTFE diaphragm                  |     |                |

---

### 3.4 Maintenance

The flow rate can be reduced by compressing the PTFE diaphragm. The set screw is tightened to achieve this.

If a greater flow rate is subsequently required, the compressed diaphragm must be replaced with a new one. Three replacement diaphragms are included with a new diaphragm tube.

Before cleaning the diaphragm, you must check the material compatibility of the cleaning method.

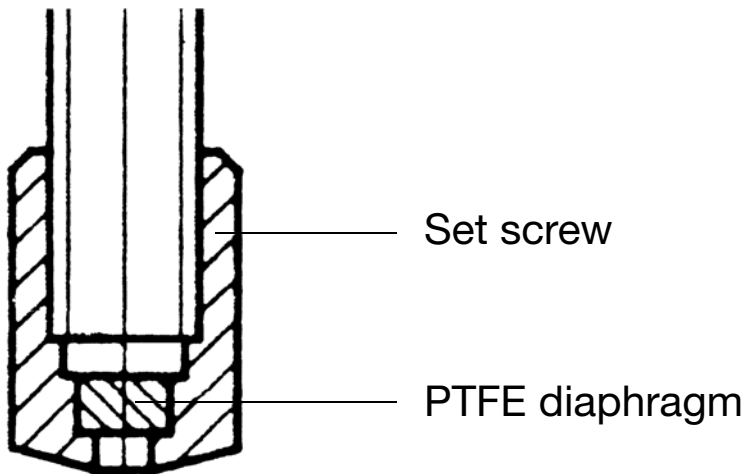

---

## 4 Compensation thermometers, type 201085

### 4.1 Application

Compensation thermometers are used in conjunction with a relevant transmitter for temperature measurement and for automatic temperature compensation during electrochemical measurements (pH, conductivity, etc.).

### 4.2 Technical data

|                              |  |
|------------------------------|--|
| Material                     | Glass  |
| permis. medium temperature   | -20 to +150 °C   |
| permis. pressure             | 0 to 10 bar at 25 °C   |
| Stem length                  | 120 mm   |
| Stem diameter                | 12 mm  |
| Active component             | Pt100<br>Basic values as defined<br>by DIN 43760,<br>Class A |
| Time constant                |  |
| • T <sub>05</sub>            | 0.8 s  |
| • T <sub>09</sub>            | 4 s  |
| Connection                   |  |
| • Type 201085/89-1003-21-120 | N plug cap   |
| • Type 201085/89-1003-22-120 | N screw plug cap Pg 13,5                                     |

---

## 4.3 Mounting

### 4.3.1 Type 201085/89-1003-21-120 – plug-in

The compensation thermometer can be plugged into a 12 mm  $\varnothing$   $+0.5$  mm/ $-0$  mm receiving hole. A PVDF M12 nut, AF19, is used as a seal.

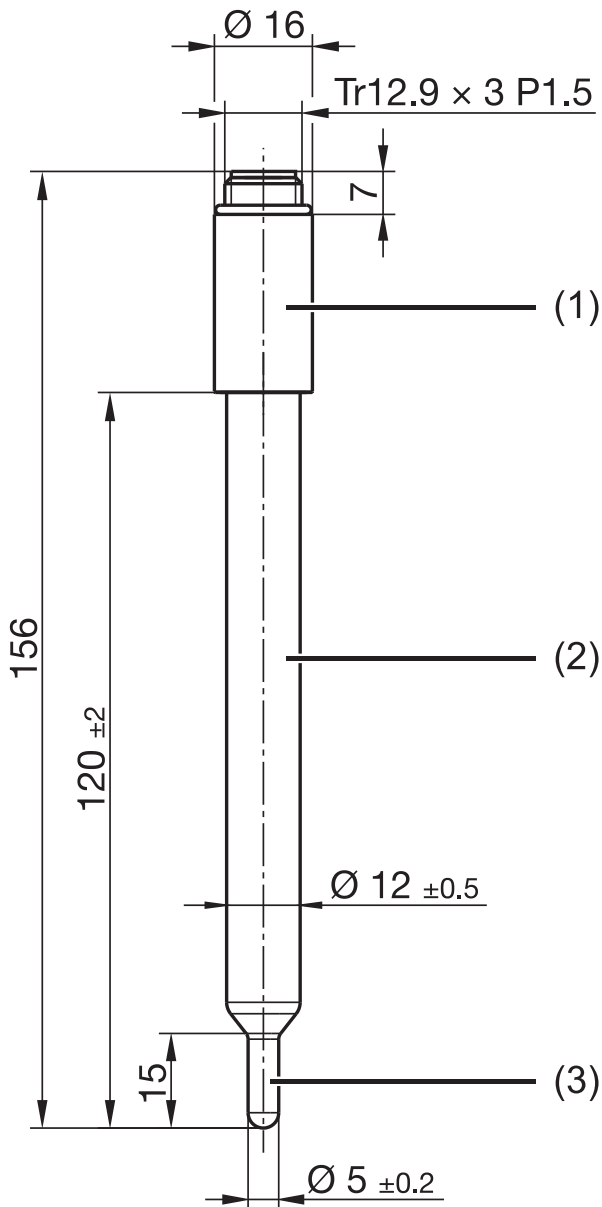

Type 201085/89-xxxx-21-120

- |     |                    |     |             |
|-----|--------------------|-----|-------------|
| (1) | S7 plug cap        | (2) | Glass shaft |
| (3) | 1x Pt100 or Pt1000 |     |             |

### 4.3.2 Type 201085/89-1003-22-120 and Type 201085/89-1003-70-120 – screw-in

The compensation thermometer can be screwed into a Pg 13.5 receiving thread; max. tightening torque 3 Nm.

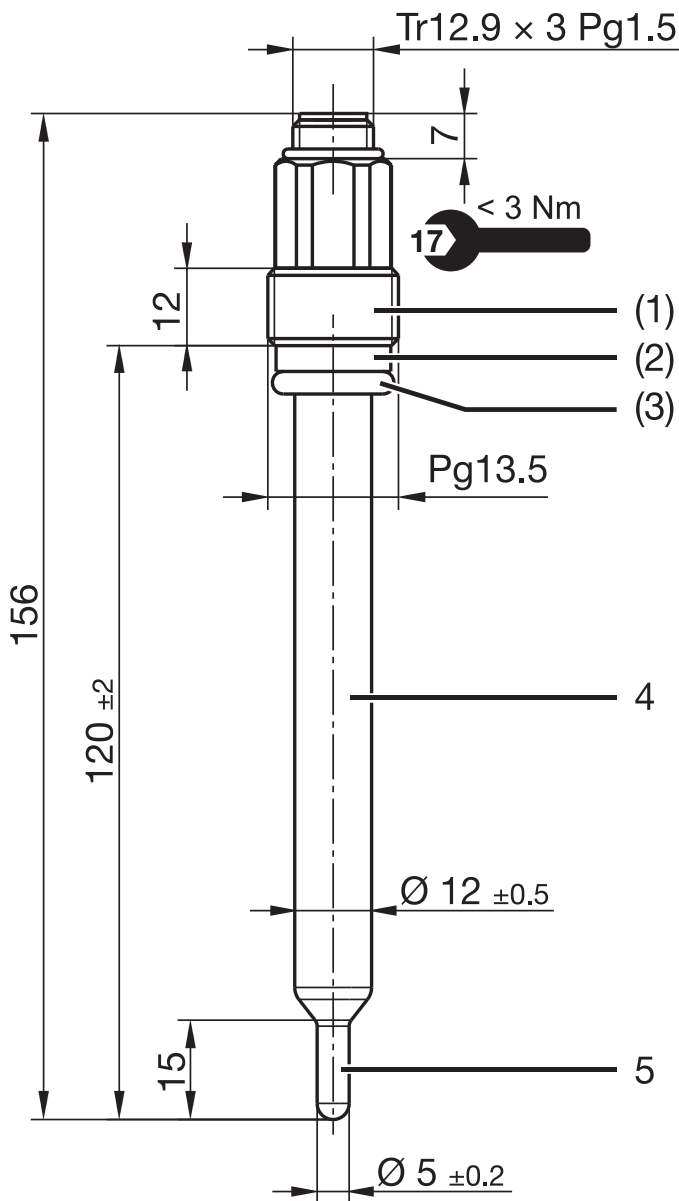

Type 201085/89-xxxx-22-120

- |     |                     |     |             |
|-----|---------------------|-----|-------------|
| (1) | Pg13.5 screw head   | (2) | Ring PSU    |
| (3) | O-ring 10 × 3,5 FPM | (4) | Glass shaft |
| (5) | 1 × Pt100 or Pt1000 |     |             |

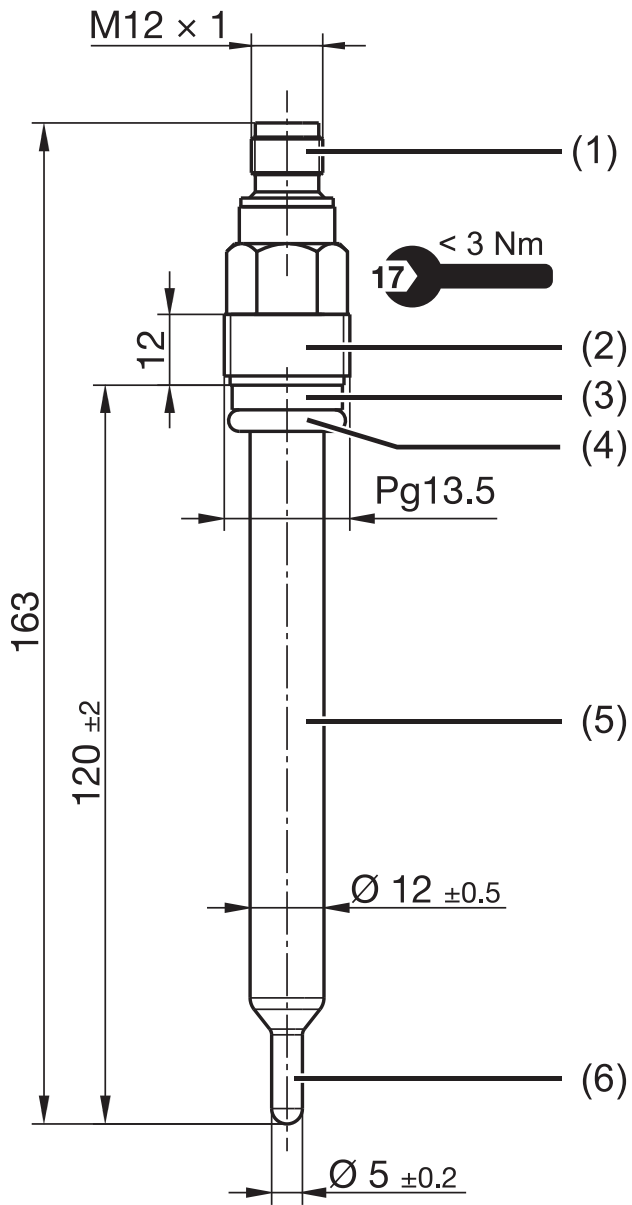

Type 201085/89-xxxx-70-120

- |     |                                    |     |                     |
|-----|------------------------------------|-----|---------------------|
| (1) | 4-pin flange connector, series 713 | (2) | Pg13.5 screw head   |
| (3) | Ring PSU                           | (4) | O-ring 10 × 3,5 FPM |
| (5) | Glass shaft                        | (6) | 1× Pt100 or Pt1000  |

---

## 5 N cable socket, type 201090

### 5.1 Application

The N cable socket is intended for subsequent assembly and is **not** included in the standard scope of delivery!

The sales no. for the N cable socket is 00057350.

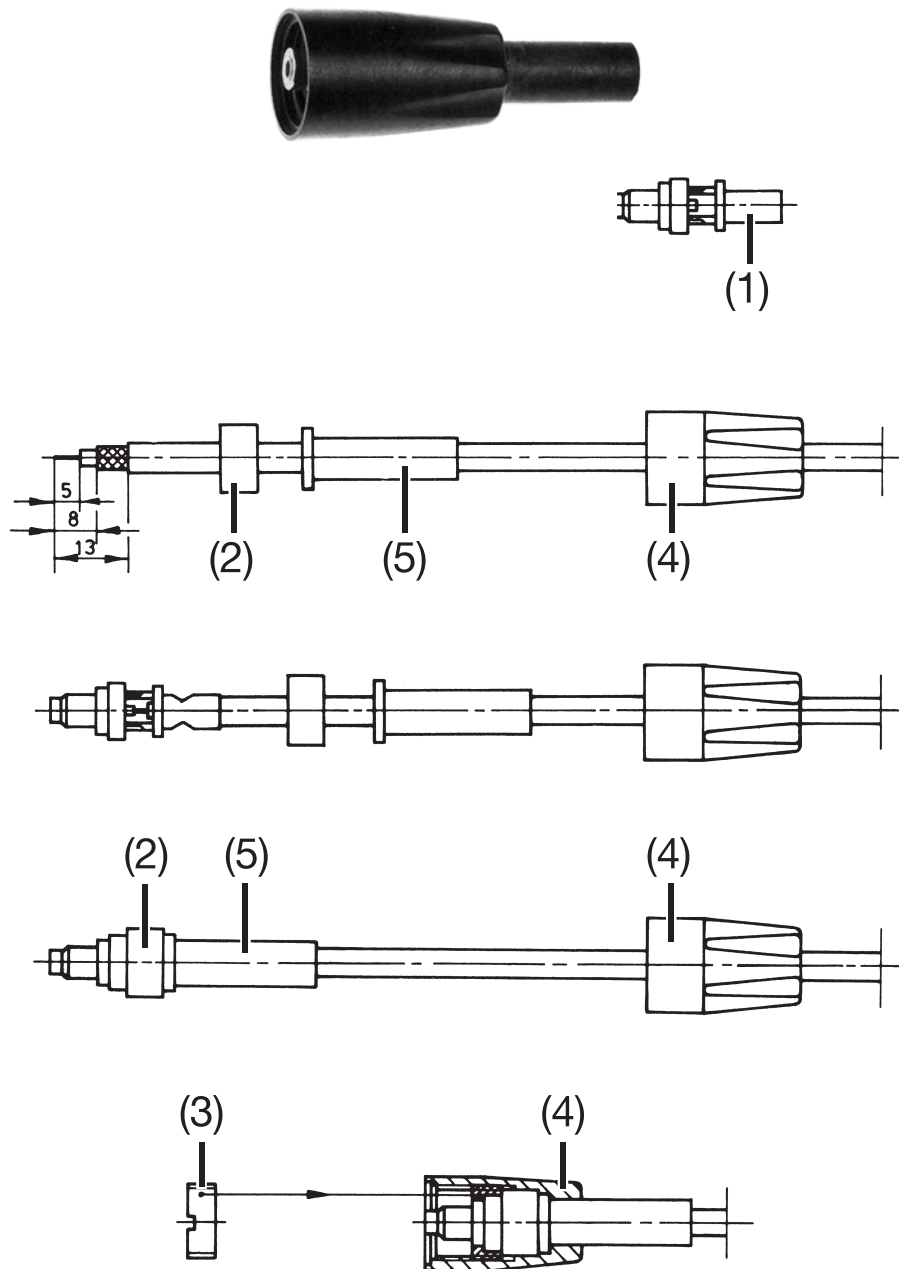

- |     |                |     |               |
|-----|----------------|-----|---------------|
| (1) | Clamping piece | (2) | Spacer sleeve |
| (3) | Set screw      | (4) | Cap           |
| (5) | Cable guide    |     |               |

---

## 5.2 Mounting

- \* Push the cap (4), cable guide (5) and spacer sleeve (2) onto the cable.
- \* Strip the cable as shown in the diagram.  
**Warning:** Remove the black, semiconducting layer!  
Do not damage the cable core when stripping the cable!
- \* Slide the clamping piece (1) over the braiding (shield) of the coaxial cable and apply pressure. Soft-solder the cable core with L-Sn 60 Pb Cu<sub>2</sub> as defined by DIN 1707.  
**Warning:** Do not use solder paste!
- \* Slide the spacer sleeve (2) over the clamping piece (1), push the cable guide (5) up to the end of the spacer sleeve (2), pull the cap (4) over it and screw it firmly into the cap (4) with the set screw (3).
- \* Check the complete coaxial cable for continuity and short-circuits.