

**James Walker**

# Compression Packing

Complete performance for all applications



High Performance Sealing Technology



# Contents

Complete performance	04
Quick reference chart	06
Lionpak® range	11
Lionpak® standard packings	12
Lionpak® specialised packings	38
Let's talk Expert2Expert	56
Supagraf® range	60
Tankatite® & TorrLid® ranges	68
Let's talk about value	78
Let's talk about manufacturing excellence	80

# Complete performance

Since the earliest days of our company, innovative James Walker products have won respect for their excellent performance and value.

Established

# 1882

Delivering the very best performance is at the heart of everything we do.



**We set new benchmarks with our standard materials, and overcome the toughest application and operational challenges in the development of our special products, so our customers can trust the James Walker name every time.**

Since 1882 our outstanding products have built a reputation for quality and reliability. From some of the earliest modern packing patents, through to the advanced materials used in today's high performance products - a desire to deliver the very best performance, value and service has remained at the heart of the James Walker business.

Through our commitment to rigorous testing and continuous improvement we stay at the forefront of compression packing sealing technology. We ensure the highest levels of product performance and value for our customers through a proven portfolio that is one of the most extensive on the market today.

#### Our ranges

##### **Lionpak®**

options to match all applications, plant operating conditions and maintenance regimes

##### **Supagraf®**

certified high performance packings for critical applications

##### **Tankatite® & TorrLid®**

the complete package for tank, crucible and furnace door sealing applications



#### Behind the brand

"...to my mind, 'The Lion' metallic packing is the best high pressure packing I have ever seen and is most economical. I have recommended your packing to other engineers and their experience in every instance has been the same as my own."

**Mr A Henderson, Chief Engineer**  
**SS Oithona, Aberdeen Steam Navigation Company**  
 1st March 1890

# Quick reference chart

Product	Valve	Rotary		Reciprocating		Static	pH
	Pressure MPa (psi)	Shaft Speed m/s (fpm)	Pressure MPa (psi)	Rod Speed m/s (fpm)	Pressure MPa (psi)	Pressure MPa (psi)	pH Range
<b>PTFE-based</b>							
Lionpak® 2100	25 (3626)	4 (787)	1 (145)	0.5 (98)	5 (725)	n/a	0-14
Lionpak® 2101	25 (3626)	4 (787)	1 (145)	0.5 (98)	5 (725)	n/a	0-14
Lionpak® 2102	25 (3626)	5 (984)	2 (290)	0.5 (98)	15 (2175)	n/a	0-14
Lionpak® 2200	15 (2175)	10 (1969)	2.5 (363)	1 (197)	10 (1450)	n/a	0-14
Lionpak® 2201	15 (2175)	10 (1969)	2.5 (363)	1 (197)	10 (1450)	n/a	0-14
Lionpak® 2202	15 (2175)	12 (2362)	2.5 (363)	1 (197)	15 (2175)	n/a	0-14
Lionpak® 2300	8 (1160)	22 (4331)	2 (290)	1 (197)	8 (1160)	n/a	0-14
Lionpak® 2302	8 (1160)	22 (4331)	1 (145)	1 (197)	8 (1160)	n/a	0-14
Lionpak® 2303	12 (1740)	17.5 (3445)	2 (290)	2 (394)	8 (1160)	n/a	0-14
Lionpak® 2500	25 (3626)	20 (3937)	2 (290)	2 (394)	10 (1450)	n/a	2-13
Lionpak® 2501	25 (3626)	20 (3937)	2 (290)	2 (394)	10 (1450)	n/a	1-13
Lionpak® 2502	25 (3626)	20 (3937)	2 (290)	2 (394)	20 (2900) <sup>‡</sup>	n/a	1-13
Lionpak® 2503	25 (3626)	20 (3937)	2 (290)	2 (394)	10 (1450)	n/a	1-13
Lionpak® 2504	25 (3626)	20 (3937)	2 (290)	2 (394)	10 (1450)	n/a	3-14
Lionpak® 2505	30 (4351)	n/a	n/a	n/a	n/a	n/a	0-14
Lionpak® 2506	25 (3626)	22 (4331)	2 (290)	2 (394)	10 (1450)	n/a	0-14
<b>Aramid-based</b>							
Lionpak® 3200	15 (2175)	20 (3937)	2.5 (363)	1.5 (295)	15 (2175)	n/a	2-13
Lionpak® 3301	15 (2175)	20 (3937)	2.5 (363)	1.5 (295)	15 (2175)	n/a	1-13
Lionpak® 3302	15 (2175)	20 (3937)	2.5 (363)	1.5 (295)	10 (1450)	n/a	0-13
<b>Graphite/Carbon-based</b>							
Lionpak® 5100	25 (3626)	25 (4921)	2.5 (363)	n/a	n/a	n/a	0-14
Lionpak® 5101	10 (1450)	20 (3937)	3.5 (508)	n/a	n/a	n/a	1-14
Lionpak® 5200	30 (4351)	n/a	n/a	n/a	n/a	n/a	0-14
Lionpak® 5201	30 (4351)	n/a	n/a	n/a	n/a	n/a	1-14
Lionpak® 5202	30 (4351)	n/a	n/a	n/a	n/a	n/a	0-14
Lionpak® 5300	15 (2175)	n/a	n/a	n/a	n/a	n/a	0-14
Lionpak® 5301	20 (2900)	20 (3937)	2 (290)	2 (394)	15 (2175) <sup>‡</sup>	n/a	0-14
Lionpak® 5302	25 (3626)	20 (3937)	2 (290)	2 (394)	10 (1450)	n/a	0-14
Lionpak® 5303	20 (2900)	20 (3937)	2 (290)	2 (394)	15 (2175) <sup>‡</sup>	n/a	0-14
Lionpak® 5304	20 (2900)	20 (3937)	2 (290)	2 (394)	15 (2175) <sup>‡</sup>	n/a	0-14
Lionpak® 5501	25 (3626)	Consult	Consult	n/a	n/a	n/a	0-14
Lionpak® 5503	25 (3626)	Consult	Consult	n/a	n/a	n/a	0-14
Lionpak® 5504	25 (3626)	Consult	Consult	n/a	n/a	n/a	0-14
Lionpak® 5505	25 (3626)	n/a	n/a	n/a	n/a	n/a	0-14

Key	
1	+450°C (+930°F) oxidising conditions, +550°C (+1202°F) steam, +850°C (+1562°F) non-oxidising
2	+450°C (+842°F) oxidising conditions, +550°C (+1022°F) steam
3	+500°C (+930°F) oxidising conditions, +650°C (+1202°F) steam, +1000°C (+1832°F) non-oxidising
4	+1000°C (+1832°F) constant, +1100°C (+2012°F) intermittent
5	+450°C (+930°F) oxidising conditions, +650°C (+1202°F) steam, +1000°C (+1832°F) non-oxidising

Temperatures		Media											More details on page	
Min °C (°F)	Max °C (°F)	Steam	Gases	Process Water	Potable Water	Strong Acids	Caustic Alkalis	Oils	Solvents	Oxygen	Food	Molten Salt		
<b>PTFE-based</b>														
-100 (-148)	+250 (+482)	✓	✓	✓	✓	✓	✓	✓	✓	✓	X	X	X	13
-100 (-148)	+250 (+482)	✓	✓	✓	X	✓	✓	✓	✓	✓	X	X	X	14
-200 (-328)	+280 (+536)	✓	✓	✓	✓	✓	✓	✓	✓	✓	X	✓	X	39
-100 (-148)	+250 (+482)	X	✓	✓	X	✓	✓	✓	✓	✓	X	X	X	15
-100 (-148)	+250 (+482)	X	✓	✓	X	✓	✓	✓	✓	✓	X	X	X	16
-100 (-148)	+280 (+536)	X	✓	✓	✓	✓	✓	✓	✓	✓	X	✓	X	40
-100 (-148)	+260 (+500)	✓	✓	✓	✓	✓	✓	✓	✓	✓	X	X	X	17
-100 (-148)	+250 (+482)	✓	✓	✓	X	✓	✓	✓	✓	✓	X	X	X	18
-100 (-148)	+260 (+500)	✓	✓	✓	X	✓	✓	✓	✓	✓	X	X	X	41
-50 (-58)	+260 (+500)	✓	✓	✓	✓	X	X	✓	✓	✓	X	X	X	19
-50 (-58)	+250 (+482)	✓	✓	✓	X	X	X	✓	✓	✓	X	X	X	42
-50 (-58)	+250 (+482)	✓	✓	✓	X	X	X	✓	✓	✓	X	X	X	43
-50 (-58)	+250 (+482)	✓	✓	✓	X	X	X	✓	✓	✓	X	X	X	20
-100 (-148)	+250 (+482)	X	✓	✓	X	✓	✓	✓	✓	✓	X	X	X	44
-200 (-328)	+260 (+500)	X	✓	✓	X	✓	✓	✓	✓	✓	X	X	X	45
-100 (-148)	+260 (+500)	✓	✓	✓	X	✓	✓	✓	✓	✓	X	X	X	46
<b>Aramid-based</b>														
-50 (-58)	+250 (+482)	✓	✓	✓	✓	X	X	✓	✓	✓	X	X	X	21
-50 (-58)	+250 (+482)	✓	✓	✓	X	X	X	✓	✓	✓	X	X	X	47
-50 (-58)	+285 (+545)	✓	✓	✓	X	X	X	✓	✓	✓	X	X	X	48
<b>Graphite/Carbon-based</b>														
-200 (-328)	+450 (+842) <sup>1</sup>	✓	✓	✓	X	✓	✓	✓	✓	✓	X	X	X	22
-200 (-328)	+450 (+842) <sup>2</sup>	✓	✓	✓	X	✓	✓	✓	✓	✓	X	X	X	23
-200 (-328)	+450 (+842) <sup>5</sup>	✓	✓	✓	X	✓	✓	✓	✓	✓	X	X	X	24
-200 (-328)	+450 (+842) <sup>2</sup>	✓	✓	✓	X	✓	✓	✓	✓	✓	X	X	X	25
-200 (-328)	+450 (+842) <sup>2</sup>	✓	✓	✓	X	✓	✓	✓	✓	✓	X	X	X	26
-50 (-58)	+550 (+1022)	✓	✓	✓	X	✓	✓	✓	✓	✓	X	X	X	27
-50 (-58)	+450 (+842)	✓	✓	✓	X	✓	✓	✓	✓	✓	X	X	✓	49
-50 (-58)	+450 (+842)	✓	✓	✓	X	✓	✓	✓	✓	✓	X	X	X	50
-50 (-58)	+350 (+662)	✓	✓	✓	X	✓	✓	✓	✓	✓	X	X	X	28
-100 (-148)	+260 (+500)	✓	✓	✓	X	✓	✓	✓	✓	✓	X	X	X	51
-200 (-328)	+500 (+932) <sup>3</sup>	✓	✓	✓	X	✓	✓	✓	✓	✓	X	X	X	29
-200 (-328)	+500 (+932) <sup>3</sup>	✓	✓	✓	X	✓	✓	✓	✓	✓	X	X	X	29
-200 (-328)	+500 (+932) <sup>3</sup>	✓	✓	✓	X	✓	✓	✓	✓	✓	X	X	X	29
-200 (-328)	+350 (+662)	✓	✓	✓	X	✓	✓	✓	✓	✓	X	X	X	52

Key	
‡	May be suitable for higher pressures on certain reciprocating duties: please consult James Walker
Consult	Dependent on application; consult James Walker
n/a	Not applicable
✓	Suitable for application
X	Not suitable for application

Operating limits quoted in this publication are not an indication that these values can be applied simultaneously, particularly when operating near to the extreme limits. Please contact James Walker if you need further guidance on the suitability of any product for your specific application.

This brochure is supported by further detailed product data sheets and product fitting instructions which are available to download from the James Walker website at [www.jameswalker.biz](http://www.jameswalker.biz)

# Quick reference chart

Product	Valve	Rotary		Reciprocating		Static	pH
	Pressure MPa (psi)	Shaft Speed m/s (fpm)	Pressure MPa (psi)	Rod Speed m/s (fpm)	Pressure MPa (psi)	Pressure MPa (psi)	pH Range
<b>Special fibre-based</b>							
Lionpak® 9100	10 (1450)	20 (3937)	2.5 (363)	1 (197)	10 (1450)	n/a	n/a
Lionpak® 9101	10 (1450)	10 (1969)	2 (290)	n/a	n/a	Consult	Consult
Lionpak® 9102	10 (1450)	10 (1969)	2 (290)	n/a	n/a	Consult	Consult
Lionpak® 9500	25 (3626)	17.5 (3445)	2 (290)	2 (394)	25 (3626)	n/a	n/a
Lionpak® 9501	10 (1450)	3 (591)	1 (145)	1 (197)	10 (1450)	n/a	n/a
Lionpak® 9600	n/a	n/a	n/a	n/a	n/a	Consult	Consult
Lionpak® 9601	n/a	n/a	n/a	n/a	n/a	Consult	Consult
Lionpak® 9602	8 (1160)	10 (1969)	2 (290)	n/a	n/a	Consult	Consult
Lionpak® 9603	n/a	n/a	n/a	n/a	n/a	Consult	Consult
Lionpak® 9605	n/a	n/a	n/a	n/a	n/a	0.5 (73)	0.5 (73)
<b>Fugitive emission packing</b>							
Supagraf® Premier	25 (3626)*	n/a	n/a	n/a	n/a	n/a	n/a
Supagraf® FE	25 (3626)*	n/a	n/a	n/a	n/a	n/a	n/a
Supagraf® Premipak	25 (3626)*	n/a	n/a	n/a	n/a	n/a	n/a
Supagraf® Control	25 (3626)	n/a	n/a	n/a	n/a	n/a	n/a
Supagraf® HT	10 (1450)	n/a	n/a	n/a	n/a	n/a	0-14
Supagraf® OX	25 (3626) <sup>6</sup>	n/a	n/a	n/a	n/a	n/a	n/a
<b>Static/tank lid seal</b>							
Tankatite® 250	n/a	n/a	n/a	n/a	n/a	0.05 (7)	0.05 (7)
Tankatite® 440	n/a	n/a	n/a	n/a	n/a	0.07 (10)	0.07 (10)
Tankatite® 660	n/a	n/a	n/a	n/a	n/a	0.06 (9)	0.06 (9)
Tankatite® 880 ACR	n/a	n/a	n/a	n/a	n/a	0.2 (29)	0.2 (29)
Tankatite® 880 Super	n/a	n/a	n/a	n/a	n/a	0.2 (29)	0.2 (29)
TorrLid® 162B	n/a	n/a	n/a	n/a	n/a	0.9 (131)	0.9 (131)
TorrLid® 297	n/a	n/a	n/a	n/a	n/a	0.9 (131)	0.9 (131)

Key	
1	+450°C (+930°F) oxidising conditions, +550°C (+1202°F) steam, +850°C (+1562°F) non-oxidising
2	+450°C (+842°F) oxidising conditions, +550°C (+1022°F) steam
3	+500°C (+930°F) oxidising conditions, +650°C (+1202°F) steam, +1000°C (+1832°F) non-oxidising
4	+1000°C (+1832°F) constant, +1100°C (+2012°F) intermittent
5	+450°C (+930°F) oxidising conditions, +650°C (+1202°F) steam, +1000°C (+1832°F) non-oxidising
6	These values are for use with gaseous oxygen

Temperatures		Media											More details on page
Min °C (°F)	Max °C (°F)	Steam	Gases	Process Water	Potable Water	Strong Acids	Caustic Alkalis	Oils	Solvents	Oxygen	Food	Molten Salt	
<b>Special fibre-based</b>													
-50 (-58)	+270 (+518)	X	✓	✓	X	✓	✓	✓	X	X	X	X	30
-50 (-58)	+250 (+482)	X	✓	✓	X	✓	✓	✓	X	X	X	X	31
-50 (-58)	+250 (+482)	X	✓	✓	X	✓	✓	✓	X	X	X	X	32
-30 (-22)	+120 (+248)	X	✓	✓	X	X	X	✓	X	X	X	X	33
-40 (-40)	+100 (+212)	X	X	✓	X	X	X	✓	X	X	X	X	34
-50 (-58)	+1000 (+1832) <sup>4</sup>	X	✓	✓	X	✓	X	✓	✓	X	X	X	35
-50 (-58)	+1000 (+1832) <sup>4</sup>	X	✓	✓	X	✓	X	✓	✓	X	X	X	53
-50 (-58)	+550 (+1022)	X	✓	✓	X	✓	X	✓	✓	X	X	X	54
-50 (-58)	+550 (+1022)	X	✓	✓	X	✓	X	✓	✓	X	X	X	36
-10 (+14)	+680 (+1256)	✓	✓	X	X	X	X	X	X	X	X	X	55
<b>Fugitive emission packing</b>													
-200 (-328)**	+450 (+842)	X	✓	X	X	X	X	✓	✓	X	X	X	62
-200 (-328)**	+450 (+842)	X	✓	X	X	X	X	✓	✓	X	X	X	63
-200 (-328)**	+450 (+842)	X	✓	X	X	X	X	✓	✓	X	X	X	64
-200 (-328)**	+350 (+662)	X	✓	X	X	X	X	✓	✓	X	X	X	65
-200 (-328)**	+650 (+1202)	✓	✓	✓	X	✓	✓	✓	✓	X	X	✓	66
-200 (-328)	+300 (+572) <sup>6</sup>	X	✓	X	X	X	X	✓	✓	✓	X	X	67
<b>Static</b>													
-30 (-22)	+100 (+212)	X	X	✓	X	✓	✓	✓	✓	X	X	X	70
-50 (-58)	+120 (+248)	X	✓	✓	X	✓	✓	✓	✓	X	X	X	71
-50 (-58)	+230 (+446)	X	X	✓	X	✓	✓	✓	✓	X	X	X	72
-50 (-58)	+250 (+482)	X	✓	✓	X	✓	✓	✓	✓	X	X	X	73
-50 (-58)	+120 (+248)	X	✓	✓	X	✓	✓	✓	✓	X	X	X	74
Consult	Consult	X	✓	X	X	X	X	✓	X	X	X	X	75
Consult	Consult	X	✓	X	X	X	X	✓	X	X	X	X	76

Key	
‡	May be suitable for higher pressures on certain reciprocating duties: please consult James Walker
Consult	Dependent on application; consult James Walker
n/a	Not applicable
✓	Suitable for application
X	Not suitable for application
**	For low temperature fugitive emissions performance please contact James Walker
*	Consult James Walker for use at higher pressures

Operating limits quoted in this publication are not an indication that these values can be applied simultaneously, particularly when operating near to the extreme limits. Please contact James Walker if you need further guidance on the suitability of any product for your specific application.

This brochure is supported by further detailed product data sheets and product fitting instructions which are available to download from the James Walker website at [www.jameswalker.biz](http://www.jameswalker.biz)

# over 30

products in the  
Lionpak® portfolio



## Lionpak® Range

The complete package for exceptional performance and value across the widest range of applications.

**Lionpak® is a comprehensive range of compression packing products offering exceptional performance and value.**

With over 30 products to choose from, Lionpak® is a range of packing options, designed and manufactured using the latest techniques and materials to meet a wide variety of technical and commercial expectations across industrial and geographical markets.

Lionpak® compression packing products are available in materials to match all applications, plant operating conditions and maintenance regimes.

- PTFE
- Aramid
- Carbon
- Graphite
- Acrylic
- Silica
- Natural fibres

In addition, Lionpak® meets the following criteria to ensure high integrity sealing in applications involving the supply of food and water:

- WRAS approved
- FDA approved
- EU 1935/2004 compliant

**For ease of understanding and navigation, we have split our Lionpak® range into two sub categories;**

### **Standard packings** Pages 12 - 36

Mainstream products used in the majority of operational applications and manufactured in a range of standard material types.

### **Specialised packings** Pages 38 - 55

Products developed to tackle the specific demands of particular applications or operating conditions. These products will usually contain unique lubricating packages, different fibre blends, or be constructed to a modified design in order to optimise performance when faced with conditions such as highly abrasive or corrosive media, for example.

### **Behind the brand**

The Lion name and icon were chosen by the company's founder to protect his very first patented packing innovation. The famous Walker Lion trade mark, for steam and hydraulic packings, first appeared in March 1889.



# Standard Packings

Lionpak® standard packings are our core products used in the majority of operational applications.

## Page reference guide

<b>Lionpak®</b> 2100	13	<b>Lionpak®</b> 2500	19	<b>Lionpak®</b> 5201	25	<b>Lionpak®</b> 9101	31
<b>Lionpak®</b> 2101	14	<b>Lionpak®</b> 2503	20	<b>Lionpak®</b> 5202	26	<b>Lionpak®</b> 9102	32
<b>Lionpak®</b> 2200	15	<b>Lionpak®</b> 3200	21	<b>Lionpak®</b> 5300	27	<b>Lionpak®</b> 9500	33
<b>Lionpak®</b> 2201	16	<b>Lionpak®</b> 5100	22	<b>Lionpak®</b> 5303	28	<b>Lionpak®</b> 9501	34
<b>Lionpak®</b> 2300	17	<b>Lionpak®</b> 5101	23	<b>Lionpak®</b> 5501/5503/5504	29	<b>Lionpak®</b> 9600	35
<b>Lionpak®</b> 2302	18	<b>Lionpak®</b> 5200	24	<b>Lionpak®</b> 9100	30	<b>Lionpak®</b> 9603	36

# Lionpak® 2100

High purity PTFE

Previously known as Fluolion® Filament D

**Lionpak® 2100 is a high-purity white packing, cross-plaited from tough thermally stable PTFE fibre yarn.**

This yarn is impregnated with densified particles of PTFE to generate extra lubrication. The packing is then cleansed of all organic matter and volatile content.

#### Prime features

- High purity, with excellent chemical resistance.
- Long life valve sealing with minimum maintenance.
- Clean and highly conformable for ease of fitting.

#### Typical applications

The purity of Lionpak® 2100 allows it to be used as a valve packing for potable water applications. It is also suitable for slow speed pumps handling chemicals.

#### Chemical properties

Compatible with media in the range pH 0-14, including corrosive acids and alkalis but excluding molten alkali metals, fluorine compounds and aqua regia.

#### How supplied

All popular square sections from 3 mm to 25 mm (1/8" to 1") in boxes containing 8 m (26' 3"), in coil form or on spools as detailed in the table below. Also supplied as split preformed rings and sets.

Spool ordering information			
Size		Packaged ± 10%	
mm	inch	kg	lbs
3.0	1/8	0.9	2
5.0	3/16	0.9	2
6.5	1/4	0.9	2
8.0	5/16	2.3	5
10.0	-	2.3	5
11.0	7/16	2.3	5
12.5	1/2	4.5	10
14.0	9/16	4.5	10
16.0	5/8	4.5	10
20.0	13/16	4.5	10
22.0	7/8	4.5	10
25.0	1	4.5	10



#### VALVE STEM DUTIES

**Maximum Operating Temperature:**  
+250°C (+482°F)  
**Minimum Operating Temperature:**  
-100°C (-148°F)  
**Maximum System Pressure:**  
25 MPa/250 bar (3626 psi)



#### CENTRIFUGAL PUMPS AND ROTARY EQUIPMENT

**Maximum Operating Temperature:**  
+250°C (+482°F)  
**Minimum Operating Temperature:**  
-100°C (-148°F)  
**Maximum Shaft Speed:**  
4 m/s (787 fpm)  
**Maximum System Pressure:**  
1 MPa/10 bar (145 psi)



#### RECIPROCATING PUMPS AND RAMS

**Maximum Operating Temperature:**  
+250°C (+482°F)  
**Minimum Operating Temperature:**  
-100°C (-148°F)  
**Maximum Rod Speed:**  
0.5 m/s (98 fpm)  
**Maximum System Pressure:**  
5 MPa/50 bar (725 psi)

#### APPROVALS



WRAS approved for use with hot and cold potable water at up to 85°C (185°F).



# Lionpak<sup>®</sup>

## 2101

Pure dry PTFE packing  
with low friction capabilities



### VALVE STEM DUTIES

Maximum Operating Temperature:  
+250°C (+482°F)

Minimum Operating Temperature:  
-100°C (-148°F)

Maximum System Pressure:  
25 MPa/250 bar (3626 psi)



### CENTRIFUGAL PUMPS AND ROTARY EQUIPMENT

Maximum Operating Temperature:  
+250°C (+482°F)

Minimum Operating Temperature:  
-100°C (-148°F)

Maximum Shaft Speed:  
4 m/s (787 fpm)

Maximum System Pressure:  
1 MPa/10 bar (145 psi)



### RECIPROCATING PUMPS AND RAMS

Maximum Operating Temperature:  
+250°C (+482°F)

Minimum Operating Temperature:  
-100°C (-148°F)

Maximum Rod Speed:  
0.5 m/s (98 fpm)

Maximum System Pressure:  
5 MPa/50 bar (725 psi)

### Lionpak<sup>®</sup> 2101 is an interlocked braided packing made of pure dry PTFE fibre yarn.

It is non-toxic, and contains no lubricants  
or additives.

#### Prime features

- Very low coefficient of friction.
- Minimal wear on shafts and sleeves.
- Long service-free life, with virtually no volume loss due to chemical action.
- Very little gland adjustment needed after initial installation.

#### Typical applications

Valves, pumps, mixers, reactors, agitators and extruders, in applications where the low friction characteristics of pure PTFE are required. Recommended for duties in compressed air systems.

#### Chemical properties

Inert to chemicals within the range pH 0-14, excluding molten alkali metals, fluorine compounds and aqua regia.

#### How supplied

All popular square sections from 3 mm to 50 mm (1/8" to 2") in boxes containing 8 m (26' 3"), in coil form or on spools as detailed in the table below. Also supplied as split preformed rings and sets.

Spool ordering information			
Size		Packaged ± 10%	
mm	inch	kg	lbs
3.0	1/8	0.9	2
5.0	3/16	0.9	2
6.5	1/4	0.9	2
8.0	5/16	0.9	2
10.0	-	2.3	5
11.0	7/16	2.3	5
12.5	1/2	2.3	5
14.0	9/16	2.3	5
16.0	5/8	4.5	10
20.0	13/16	4.5	10
22.0	7/8	4.5	10
25.0	1	4.5	10

# Lionpak<sup>®</sup>

## 2200

Cross-plaited thermally  
stable PTFE packing

Previously known as Fluolion<sup>®</sup> Filament L



### VALVE STEM DUTIES

Maximum Operating Temperature:  
+250°C (+482°F)

Minimum Operating Temperature:  
-100°C (-148°F)

Maximum System Pressure:  
15 MPa/150 bar (2175 psi)



### CENTRIFUGAL PUMPS AND ROTARY EQUIPMENT

Maximum Operating Temperature:  
+250°C (+482°F)

Minimum Operating Temperature:  
-100°C (-148°F)

Maximum Shaft Speed:  
10 m/s (1969 fpm)

Maximum System Pressure:  
2.5 MPa/25 bar (363 psi)



### RECIPROCATING PUMPS AND RAMS

Maximum Operating Temperature:  
+250°C (+482°F)

Minimum Operating Temperature:  
-100°C (-148°F)

Maximum Rod Speed:  
1.0 m/s (197 fpm)

Maximum System Pressure:  
10 MPa/100 bar (1450 psi)

### Lionpak<sup>®</sup> 2200 is a cross-plaited packing made from tough thermally stable PTFE fibre yarn.

Impregnated with densified particles of  
PTFE to generate additional lubrication.

#### Prime features

- Excellent chemical resistance.
- High performance sealing in valve and pump applications.
- Long and efficient working life with minimum maintenance requirements.
- Clean and highly conformable for ease of fitting.

#### Typical applications

This high performance packing is used where its exceptional chemical resistance is required in valves, rotary equipment and reciprocating plant.

#### Chemical properties

Compatible with media in the range pH 0-14, including corrosive acids and alkalis but excluding molten alkali metals, fluorine compounds and aqua regia.

#### How supplied

All popular square sections from 3 mm to 25 mm (1/8" to 1") in boxes containing 8 m (26' 3"), in coil form or on spools as detailed in the table below. Also supplied as split preformed rings and sets.

Spool ordering information			
Size		Packaged ± 10%	
mm	inch	kg	lbs
3.0	1/8	0.9	2
5.0	3/16	0.9	2
6.5	1/4	0.9	2
8.0	5/16	2.3	5
10.0	-	2.3	5
11.0	7/16	2.3	5
12.5	1/2	4.5	10
14.0	9/16	4.5	10
16.0	5/8	4.5	10
20.0	13/16	4.5	10
22.0	7/8	4.5	10
25.0	1	4.5	10



# Lionpak®

## 2201

Dimensionally stable PTFE  
for chemical processing



### VALVE STEM DUTIES

Maximum Operating Temperature:

+250°C (+482°F)

Minimum Operating Temperature:

-100°C (-148°F)

Maximum System Pressure:

15 MPa/150 bar (2175 psi)



### CENTRIFUGAL PUMPS AND ROTARY EQUIPMENT

Maximum Operating Temperature:

+250°C (+482°F)

Minimum Operating Temperature:

-100°C (-148°F)

Maximum Shaft Speed:

10 m/s (1969 fpm)

Maximum System Pressure:

2.5 MPa/25 bar (363 psi)



### RECIPROCATING PUMPS AND RAMS

Maximum Operating Temperature:

+250°C (+482°F)

Minimum Operating Temperature:

-100°C (-148°F)

Maximum Rod Speed:

1.0 m/s (197 fpm)

Maximum System Pressure:

10 MPa/100 bar (1450 psi)

### Lionpak® 2201 is a duplex braided packing of pure PTFE fibre yarns.

It contains James Walker's proprietary break-in lubricant and a PTFE dispersion.

#### Prime features

- Non-toxic and inert to protect the purity and safety of fluid media.
- Dimensionally stable to ensure trouble-free operational life with reduced maintenance costs.
- Inlube break-in lubricant provides additional lubrication during the complete operational life of the product.
- PTFE dispersion acts as a blocking agent and antifriction additive.

#### Typical applications

Recommended for both static and dynamic operations with pumps, valves, mixers, reactors, agitators, dryers and air compressors. Suitable for duties with acids and alkalis of any concentration, solvents, organic and inorganic chemicals, petrochemicals, dyestuffs, paints and synthetic resins.

#### Chemical properties

Compatible with media in the range pH 0-14, excluding strong oxidisers, molten alkali metals and fluorine compounds and aqua regia.

#### How supplied

All popular square sections from 3 mm to 50 mm (1/8" to 2") in boxes containing 8 m (26' 3"), in coil form or on spools as detailed in the table below. Also supplied as split preformed rings and sets.

Spool ordering information			
Size		Packaged ± 10%	
mm	inch	kg	lbs
3.0	1/8	0.9	2
5.0	3/16	0.9	2
6.5	1/4	0.9	2
8.0	5/16	0.9	2
10.0	-	2.3	5
11.0	7/16	2.3	5
12.5	1/2	2.3	5
14.0	9/16	2.3	5
16.0	5/8	4.5	10
20.0	13/16	4.5	10
22.0	7/8	4.5	10
25.0	1	4.5	10

# Lionpak®

## 2300

100% GFO® yarn packing  
Previously known as Fluograt®



### Lionpak® 2300 is a highly versatile product that adds a new dimension to compression packing reliability and performance.

Made totally from WL Gore & Associates' highly developed GFO® yarn - combining the benefits of ePTFE, graphite and high temperature lubricants - this cross-plaited packing offers the ideal balance between density, resilience, strength and durability.

#### Prime features

- Extended service life - by up to 400% in harsh environments.
- Well proven with aggressive media.
- High thermal conductivity for cool running.
- Low coefficient of friction and minimal shaft wear.
- Very good start-up and emergency running characteristics.
- Non-hardening.

#### Typical applications

Valves and pumps handling aggressive chemical media in the petrochemical, pulp and paper, power generation and metallurgical sectors - as well as potable water, and steam at up to 260°C (500°F).

#### Chemical properties

Compatible with media in the range pH 0-14 including steam, but excluding strong oxidising agents such as aqua regia, fuming nitric acid, oleum, and molten alkali metals.

#### How supplied

All popular square sections from 3 mm to 25 mm (1/8" to 1") in boxes containing 8 m (26' 3"), in coil form or on spools as detailed in the table below. Also supplied as split preformed rings and sets.

Spool ordering information			
Size		Packaged ± 10%	
mm	inch	kg	lbs
3.0	1/8	0.9	2
5.0	3/16	0.9	2
6.5	1/4	0.9	2
8.0	5/16	2.3	5
10.0	-	2.3	5
11.0	7/16	2.3	5
12.5	1/2	4.5	10
14.0	9/16	4.5	10
16.0	5/8	4.5	10
20.0	13/16	4.5	10
22.0	7/8	4.5	10
25.0	1	4.5	10

#### Notes:

\*Refer to James Walker for duties up to 28 m/s (5512 fpm).

\*\*More severe duties can be sealed with specially designed arrangements. GFO® is a registered trademark of WL Gore & Associates.



### VALVE STEM DUTIES

Maximum Operating Temperature:

+260°C (+500°F)

Minimum Operating Temperature:

-100°C (-148°F)

Maximum System Pressure:

8 MPa/80 bar (1160 psi)



### CENTRIFUGAL PUMPS AND ROTARY EQUIPMENT

Maximum Operating Temperature:

+260°C (+500°F)

Minimum Operating Temperature:

-100°C (-148°F)

Maximum Shaft Speed:

22 m/s (4331 fpm)\*

Maximum System Pressure:

2 MPa/20 bar (290 psi)



### RECIPROCATING PUMPS AND RAMS

Maximum Operating Temperature:

+260°C (+500°F)

Minimum Operating Temperature:

-100°C (-148°F)

Maximum Rod Speed:

1.0 m/s (197 fpm)

Maximum System Pressure:

8 MPa/80 bar (1160 psi)\*\*

### APPROVALS



WRAS approved for use with potable water up to 85°C (185°F)



# Lionpak®

## 2302

PTFE/graphite for resilience  
and excellent chemical resistance

**Lionpak® 2302 is an improved duplex braided packing of expanded PTFE with high quality graphite intimately entrapped in the porous structure of the PTFE resin.**

The product is further lubricated with molybdenum disulphide (MoS<sub>2</sub>).

#### Prime features

- A dense packing offering a high degree of resilience and dimensional stability.
- The graphite provides heat dissipation to enhance the product's long and efficient working life, which is also improved by the excellent thermal conductivity of molybdenum disulphide.
- Molybdenum disulphide enhances high speed rotary operations by minimising friction and wear.
- The molybdenum disulphide content also provides good chemical resistance.

#### Typical applications

Centrifugal and reciprocating pumps, valves, large diameter shafts, reactor vessels, agitators, mixers and autoclaves. Suitable for duties with acids and alkalis of any concentration, phosphoric acid, hydrocarbons, solvents, raw water, demineralised water, condensate and cooling water.

#### Chemical properties

Compatible with media in the range pH 0-14, excluding strong oxidisers, molten alkali metals and fluorine compounds.

#### How supplied

All popular square sections from 3 mm to 50 mm (1/8" to 2") in boxes containing 8 m (26' 3"), in coil form or on spools as detailed in the table below. Also supplied as split preformed rings and sets.

Spool ordering information			
Size		Packaged ± 10%	
mm	inch	kg	lbs
3.0	1/8	0.9	2
5.0	3/16	0.9	2
6.5	1/4	0.9	2
8.0	5/16	2.3	5
10.0	-	2.3	5
11.0	7/16	2.3	5
12.5	1/2	4.5	10
14.0	9/16	4.5	10
16.0	5/8	4.5	10
20.0	13/16	4.5	10
22.0	7/8	4.5	10
25.0	1	4.5	10



#### VALVE STEM DUTIES

Maximum Operating Temperature:

+250°C (+482°F)

Minimum Operating Temperature:

-100°C (-148°F)

Maximum System Pressure:

8 MPa/80 bar (1160 psi)



#### CENTRIFUGAL PUMPS AND ROTARY EQUIPMENT

Maximum Operating Temperature:

+250°C (+482°F)

Minimum Operating Temperature:

-100°C (-148°F)

Maximum Shaft Speed:

22 m/s (4331 fpm)

Maximum System Pressure:

1 MPa/10 bar (145 psi)



#### RECIPROCATING PUMPS AND RAMS

Maximum Operating Temperature:

+250°C (+482°F)

Minimum Operating Temperature:

-100°C (-148°F)

Maximum Rod Speed:

1.0 m/s (197 fpm)

Maximum System Pressure:

8 MPa/80 bar (1160 psi)



# Lionpak®

## 2500

Tough, high performance  
packing with elastomer core  
Previously known as Hornet

**Lionpak® 2500 is a high performance packing that absorbs the eccentric action of worn shafts, spindles and bearings. It has a central core of temperature resistant elastomer.**

This square sectioned packing is cross-plaited with tough aramid fibres at the corners to resist abrasion and wear. PTFE/graphite yarn at the centre of each side dissipates heat and presents a low friction face to the shaft or spindle.

#### Prime features

- Excellent abrasion resistance.
- Superior compression and recovery characteristics with out-of-true shafts and spindles.
- Excellent extrusion resistance.
- Low shaft wear.
- The high density elastomeric core provides resilience and resistance to high working pressures, and can absorb the vibration and eccentric movement created by worn running surfaces.

#### Typical applications

Valves and pumps handling abrasive and aggressive slurries in pulp and paper mills, petrochemical plants, sewage works, metallurgical plants and china clay works. Also suitable for potable water and steam.

#### Chemical properties

Compatible with media in the range pH 2-13, including water, steam, fuels, oils, solvents, waxes, and mild acids and alkalis.

#### How supplied

All popular square sections from 5 mm to 25 mm (3/16" to 1") in boxes containing 8 m (26' 3"), in coil form or on spools as detailed in the table below. Also supplied as split preformed rings and sets.

Spool ordering information			
Size		Packaged ± 10%	
mm	inch	kg	lbs
5.0	3/16	0.9	2
6.5	1/4	0.9	2
8.0	5/16	2.3	5
10.0	-	2.3	5
11.0	7/16	2.3	5
12.5	1/2	4.5	10
14.0	9/16	4.5	10
16.0	5/8	4.5	10
20.0	13/16	4.5	10
22.0	7/8	4.5	10
25.0	1	4.5	10



#### VALVE STEM DUTIES

Maximum Operating Temperature:

+260°C (+500°F)

Minimum Operating Temperature:

-50°C (-58°F)

Maximum System Pressure:

25 MPa/250 bar (3626 psi)



#### CENTRIFUGAL PUMPS AND ROTARY EQUIPMENT

Maximum Operating Temperature:

+260°C (+500°F)

Minimum Operating Temperature:

-50°C (-58°F)

Maximum Shaft Speed:

20 m/s (3937 fpm)

Maximum System Pressure:

2.5 MPa/20 bar (290 psi)



#### RECIPROCATING PUMPS AND RAMS

Maximum Operating Temperature:

+260°C (+500°F)

Minimum Operating Temperature:

-50°C (-58°F)

Maximum Rod Speed:

2.0 m/s (394 fpm)

Maximum System Pressure:

10 MPa/100 bar (1450 psi)

#### APPROVALS



WRAS approved for use with cold and hot potable water up to 85°C (185°F)



# Lionpak®

## 2503

PTFE/graphite/aramid for highly abrasive chemical media

**Lionpak® 2503 is a combination packing, with tough but smooth aramid fibre yarn at the corners, ePTFE/graphite solid yarn with a break-in lubricant at the faces, and a solid core of extruded elastomeric cord.**

The aramid yarn is impregnated with an antifriction fluoropolymer dispersion and a special break-in lubricant.

#### Prime features

- Exceedingly durable packing, with inherent dimensional stability, that offers high integrity sealing throughout its long operational life.
- PTFE/graphite running faces provide excellent heat dissipation with cool running.
- Aramid yarn at its corners helps to withstand the rigours of reciprocating plunger pump operation.
- The high density elastomeric core provides resilience and resistance to high working pressures, and can absorb the vibration and eccentric movement created by worn running surfaces.

#### Typical applications

Pumps, valves, reactors, autoclaves, mixers, agitators, refiners, pistons, hydraulic presses and hammers. It can also be used as a replacement for traditional lip seals in certain applications.

Recommended for duties with ammonia and carbamate solutions. Also suitable for use with oxidising and non-oxidising liquids and gases, fine chemical slurries, hydrazine, trisodium phosphate, sodium hexametaphosphate, black and green liquor, paper pulp, pulp diluted with water, water slurries, acids, alkalis and molasses.

#### Chemical properties

Compatible with media in the range pH 1-13.

#### How supplied

All popular square sections from 6.5 mm (1/4" to 1") in boxes containing 8 m (26' 3"), in coil form or on spools as detailed in the table below. Also supplied as split preformed rings and sets.

Spool ordering information			
Size		Packaged ± 10%	
mm	inch	kg	lbs
6.5	1/4	0.9	2
8.0	5/16	0.9	2
10.0	-	2.3	5
11.0	7/16	2.3	5
12.5	1/2	2.3	5
14.0	9/16	2.3	5
16.0	5/8	4.5	10
20.0	13/16	4.5	10
22.0	7/8	4.5	10
25.0	1	4.5	10

# Lionpak®

## 3200

Tough, high performance aramid packing resistant to chemicals at high temperature  
Previously known as Duramid®

**Lionpak® 3200 is a tough, high performance packing, cross-plaited from texturised aramid yarns.**

Each yarn is uniformly impregnated with PTFE dispersion and a silicone-based lubricant that resists chemical attack at high temperatures.

#### Prime features

- Suitable for a very wide range of media.
- Excellent abrasion resistance.
- Long service life with minimal shaft wear.
- Resilient and responsive in operation.

#### Typical applications

Valves and pumps handling abrasive and aggressive media in pulp and paper mills, petrochemical plants, power stations, metallurgical plants, sewage works and china clay works. Also suitable for potable water, medium pressure steam, and hardening fluids such as tar and bitumen.

#### Chemical properties

Compatible with media in the range pH 2-13, including water, oils, solvents, medium strength acids and alkalis.

#### How supplied

All popular square sections from 3 mm to 25 mm (1/8" to 1") in boxes containing 8 m (26' 3"), in coil form or on spools as detailed in the table below. Also supplied as split preformed rings and sets.

Spool ordering information			
Size		Packaged ± 10%	
mm	inch	kg	lbs
3.0	1/8	0.9	2
5.0	3/16	0.9	2
6.5	1/4	0.9	2
8.0	5/16	2.3	5
10.0	-	2.3	5
11.0	7/16	2.3	5
12.5	1/2	4.5	10
14.0	9/16	4.5	10
16.0	5/8	4.5	10
20.0	13/16	4.5	10
22.0	7/8	4.5	10
25.0	1	4.5	10

Notes: \*Refer to James Walker for higher speed duties.



#### VALVE STEM DUTIES

Maximum Operating Temperature: +250°C (+482°F)  
Minimum Operating Temperature: -50°C (-58°F)  
Maximum System Pressure: 15 MPa/150 bar (2175 psi)

#### CENTRIFUGAL PUMPS AND ROTARY EQUIPMENT

Maximum Operating Temperature: +250°C (+482°F)  
Minimum Operating Temperature: -50°C (-58°F)  
Maximum Shaft Speed: 20 m/s (3937 fpm)\*  
Maximum System Pressure: 2.5 MPa/25 bar (363 psi)

#### RECIPROCATING PUMPS AND RAMS

Maximum Operating Temperature: +250°C (+482°F)  
Minimum Operating Temperature: -50°C (-58°F)  
Maximum Rod Speed: 1.5 m/s (295 fpm)  
Maximum System Pressure: 15 MPa/150 bar (2175 psi)

#### APPROVALS

 WRAS approved for use with cold and hot potable water up to 85°C (185°F)



#### VALVE STEM DUTIES

Maximum Operating Temperature: +250°C (+482°F)  
Minimum Operating Temperature: -50°C (-58°F)  
Maximum System Pressure: 25 MPa/250 bar (3626 psi)



#### CENTRIFUGAL PUMPS AND ROTARY EQUIPMENT

Maximum Operating Temperature: +250°C (+482°F)  
Minimum Operating Temperature: -50°C (-58°F)  
Maximum Shaft Speed: 20 m/s (3937 fpm)  
Maximum System Pressure: 2 MPa/20 bar (290 psi)



#### RECIPROCATING PUMPS AND RAMS

Maximum Operating Temperature: +250°C (+482°F)  
Minimum Operating Temperature: -50°C (-58°F)  
Maximum Rod Speed: 2.0 m/s (394 fpm)  
Maximum System Pressure: 10 MPa/100 bar (1450 psi)



# Lionpak<sup>®</sup>

## 5100

High purity exfoliated graphite packing  
Previously known as Ribbonpak

**Lionpak<sup>®</sup> 5100 is a high purity exfoliated 98% graphite ribbon, plaited into a length-form packing for convenient on-site maintenance.**

**Prime features**

- Excellent chemical resistance across an exceptionally wide temperature range.
- Replaces moulded graphite sealing rings.
- Flexible and compressible.
- Easy to install - no special tools needed.
- Reduces stockholding requirements.

**Typical applications**

High speed rotary pumps handling water or slurry in pulp and paper processing. Also a general purpose valve stem packing for steam and chemical processing duties.

**Chemical properties**

Compatible with media in the range pH 0-14, excluding strong oxidising agents. Negligible volatile content. Low in extractable trace impurities such as chloride and sulphur.

**How supplied**

All popular square sections from 3 mm (1/8") upwards in boxes containing 8 m (26' 3"), in coil form or on spools as detailed in the table below. Also supplied as split preformed rings and sets.

Spool ordering information			
Size		Packaged ± 10%	
mm	inch	kg	lbs
3.0	1/8	0.9	2
5.0	3/16	0.9	2
6.5	1/4	2.3	5
8.0	5/16	2.3	5
10.0	-	2.3	5
11.0	7/16	2.3	5
12.5	1/2	2.3	5
14.0	9/16	4.5	10
16.0	5/8	4.5	10
20.0	13/16	4.5	10
22.0	7/8	4.5	10
25.0	1	4.5	10



**VALVE STEM DUTIES**

Maximum Operating Temperatures: Steam

+550°C (+1022°F)

Oxidising conditions

+450°C (+842°F)

Non-oxidising

+850°C (+1562°F)

Minimum Operating Temperature:

-200°C (-328°F)

Maximum System Pressure:

25 MPa/250 bar (3626 psi)



**CENTRIFUGAL PUMPS AND ROTARY EQUIPMENT**

Maximum Operating Temperatures: Steam

+550°C (+1022°F)

Oxidising conditions

+450°C (+842°F)

Non-oxidising

+850°C (+1562°F)

Minimum Operating Temperature:

-200°C (-328°F)

Maximum Shaft Speed:

25 m/s (4921 fpm)

Maximum System Pressure:

2.5 MPa/25 bar (363 psi)



# Lionpak<sup>®</sup>

## 5101

Reinforced graphite for high integrity sealing with aggressive media

**Lionpak<sup>®</sup> 5101 is a braided packing comprising expanded graphite fibre, with 99% minimum purity, reinforced with a non-metallic filament.**

It is impregnated with James Walker's proprietary high temperature, graphite-based dispersion to enhance sealability.

**Prime features**

- High integrity sealing over long operational periods.
- Excellent chemical resistance across a very wide temperature range.
- Lubrication system assists self-adjustment when the gland is tightened.

**Typical applications**

Centrifugal pumps, valves, dryers and reactors. Suitable for use with superheated and saturated steam, gases, petrochemicals, hydrocarbons, hot oil, thermic fluid, acids and alkalis, solvents, organic chemicals, emissive fluids and nitrous oxide.

Please note that this packing is unsuitable for reciprocating duties.

**Chemical properties**

Compatible with media in the range pH 0-14, excluding strong oxidising agents.

**How supplied**

All popular square sections from 3 mm to 50 mm (1/8" to 2") in boxes containing 8 m (26' 3"), in coil form or on spools as detailed in the table below. Also supplied as split preformed rings and sets.

Spool ordering information			
Size		Packaged ± 10%	
mm	inch	kg	lbs
3.0	1/8	0.9	2
5.0	3/16	0.9	2
6.5	1/4	0.9	2
8.0	5/16	0.9	2
10.0	-	2.3	5
11.0	7/16	2.3	5
12.5	1/2	2.3	5
14.0	9/16	2.3	5
16.0	5/8	4.5	10
20.0	13/16	4.5	10
22.0	7/8	4.5	10
25.0	1	4.5	10



**VALVE STEM DUTIES**

Maximum Operating Temperatures: Steam

+550°C (+1022°F)

Oxidising conditions

+450°C (+842°F)

Minimum Operating Temperature:

-200°C (-328°F)

Maximum System Pressure:

10 MPa/100 bar (1450 psi)



**CENTRIFUGAL PUMPS AND ROTARY EQUIPMENT**

Maximum Operating Temperatures: Steam

+550°C (+1022°F)

Oxidising conditions

+450°C (+842°F)

Minimum Operating Temperature:

-200°C (-328°F)

Maximum Shaft Speed:

20 m/s (3937 fpm)

Maximum System Pressure:

3.5 MPa/35 bar (508 psi)



# Lionpak<sup>®</sup>

## 5200

High purity exfoliated graphite packing with Inconel<sup>®</sup> reinforcement

Previously known as Ribbonpak Type M

**Lionpak<sup>®</sup> 5200 is a premium grade packing comprising exfoliated graphite fibre of high 98% carbon content, reinforced with Inconel<sup>®</sup> wires.**

The graphite fibres are reinforced with fine Inconel<sup>®</sup> wires and are dry having no additives or dispersion in order to maximise temperature capabilities.

#### Prime features

- Wire reinforcement enhances the mechanical strength of the packing to resist high pressures.
- Exceptional temperature range.
- Low friction and high thermal conductivity.
- Easy to cut, shape and install.
- Excellent chemical resistance.
- Long service life with rotary or rising stem valves.
- Conforms to Shell material specification MESC SPE 85/204.

#### Typical applications

Valves handling steam, condensate, fuel, oils, gases, chemicals, process water or effluent. This product is widely used in petrochemical plants, refineries, power stations and steel mills.

#### Chemical properties

Compatible with media in the range pH 0-14, excluding strong oxidising agents. Negligible volatile content. Low in extractable trace impurities such as chloride and sulphur.

#### How supplied

All popular square sections from 3 mm (1/8") upwards in boxes containing 8 m (26' 3"), in coil form or on spools as detailed in the table below. Also supplied as split preformed rings and sets.

Spool ordering information			
Size		Packaged ± 10%	
mm	inch	kg	lbs
3.0	1/8	0.9	2
5.0	3/16	0.9	2
6.5	1/4	0.9	2
8.0	5/16	0.9	2
10.0	-	2.3	5
11.0	7/16	2.3	5
12.5	1/2	2.3	5
14.0	9/16	4.5	10
16.0	5/8	4.5	10
20.0	13/16	4.5	10
22.0	7/8	4.5	10
25.0	1	4.5	10

**Notes:** Inconel<sup>®</sup> is a registered trademark of Special Metals Corporation.



#### VALVE STEM DUTIES

Maximum Operating Temperatures: Steam

+650°C (+1202°F)

Oxidising conditions

+450°C (+842°F)

Non-oxidising

+1000°C (+1832°F)

Minimum Operating Temperature:

-200°C (-328°F)

Maximum System Pressure:

30 MPa/300 bar (4351 psi)

#### APPROVALS

Shell MESC SPE 85/204



# Lionpak<sup>®</sup>

## 5201

Expanded graphite packing reinforced with Inconel<sup>®</sup> wire

**Lionpak<sup>®</sup> 5201 is a packing comprising soft expanded graphite fibre of high 99% carbon content, reinforced with multiple Inconel<sup>®</sup> wires in each strand.**

The fibres are impregnated with James Walker's proprietary, high temperature, graphite-based dispersion, and the packing is further treated with an inorganic passive corrosion inhibitor.

#### Prime features

- Multiple wire reinforcement enhances the mechanical strength of the packing where pressure fluctuations and/or surges occur.
- Graphite-based dispersion acts as a blocking agent.
- Corrosion inhibitor safeguards metallic interfaces from galvanic corrosion.
- Easy to cut, shape and install.
- Excellent chemical resistance.
- Third-party tested and certified to: API 607 Edition 7 Fire Safety / ISO 10497:2010.

#### Typical applications

Mainly valves and soot blowers, although it can be used at low speeds on rotary kilns and dryers. Suitable for use with superheated and saturated steam, hydrocarbons, petrochemicals, solvents, thermic fluid, acids, alkalis and gases.

#### Chemical properties

Compatible with media in the range pH 0-14, excluding strong oxidising agents.

#### How supplied

All popular square sections from 3 mm to 50 mm (1/8" to 2") in boxes containing 8 m (26' 3"), in coil form or on spools as detailed in the table below. Also supplied as split preformed rings and sets.

Spool ordering information			
Size		Packaged ± 10%	
mm	inch	kg	lbs
3.0	1/8	0.9	2
5.0	3/16	0.9	2
6.5	1/4	0.9	2
8.0	5/16	0.9	2
10.0	-	2.3	5
11.0	7/16	2.3	5
12.5	1/2	2.3	5
14.0	9/16	2.3	5
16.0	5/8	4.5	10
20.0	13/16	4.5	10
22.0	7/8	4.5	10
25.0	1	4.5	10

**Notes:** Inconel<sup>®</sup> is a registered trademark of Special Metals Corporation.



#### VALVE STEM DUTIES

Maximum Operating Temperatures: Steam

+550°C (+1022°F)

Oxidising conditions

+450°C (+842°F)

Minimum Operating Temperature:

-200°C (-328°F)

Maximum System Pressure:

30 MPa/300 bar (4351 psi)

#### APPROVALS

API 607 Edition 7  
Fire Safety



# Lionpak<sup>®</sup>

## 5202

Expanded graphite packing reinforced with Inconel<sup>®</sup> wire

**Lionpak<sup>®</sup> 5202 is an economical packing made of expanded high purity 99% graphite fibre reinforced with a single Inconel<sup>®</sup> wire in each strand.**

The packing is reinforced with Inconel<sup>®</sup> wire and is impregnated with James Walker's proprietary graphite-based dispersion to enhance sealability, and further treated with a corrosion inhibitor.

#### Prime features

- Single wire reinforcement enhances the mechanical strength of the packing to resist continuous pressure.
- Graphite-based dispersion acts as a blocking agent.
- Corrosion inhibitor safeguards metallic interfaces from galvanic corrosion.
- Easy to cut, shape and install.
- Excellent chemical resistance.

#### Typical applications

Valves and autoclaves, but can also be used on slow speed rotary duties with rotary kilns. Suitable for use with superheated steam and saturated steam, hydrocarbons, petrochemicals, thermic fluids and hot oils.

#### Chemical properties

Compatible with media in the range pH 0-14, excluding strong oxidising agents.

#### How supplied

All popular square sections from 3 mm ( $\frac{1}{8}$ " to 2") in boxes containing 8 m (26' 3"), in coil form or on spools as detailed in the table below. Also supplied as split preformed rings and sets.

Spool ordering information			
Size		Packaged $\pm$ 10%	
mm	inch	kg	lbs
3.0	$\frac{1}{8}$	0.9	2
5.0	$\frac{3}{16}$	0.9	2
6.5	$\frac{1}{4}$	0.9	2
8.0	$\frac{5}{16}$	0.9	2
10.0	-	2.3	5
11.0	$\frac{7}{16}$	2.3	5
12.5	$\frac{1}{2}$	2.3	5
14.0	$\frac{9}{16}$	2.3	5
16.0	$\frac{5}{8}$	4.5	10
20.0	$\frac{13}{16}$	4.5	10
22.0	$\frac{7}{8}$	4.5	10
25.0	1	4.5	10

**Notes:** Inconel<sup>®</sup> is a registered trademark of Special Metals Corporation.



# Lionpak<sup>®</sup>

## 5300

Premier quality graphite packing with corrosion inhibitors

Previously known as Grafpak

**Lionpak<sup>®</sup> 5300 is a dense, high strength packing of cross-plaited premier quality graphite filament yarns.**

Treated with pure graphite before and after plaiting, and further treated with corrosion inhibitors.

#### Prime features

- Suitable for a wide range of aggressive media at elevated temperatures.
- Low friction for low torque valve action.
- Tough and resistant to fretting and extrusion.

#### Typical applications

Control valves and main stop valves on high temperature/pressure steam circuits at power stations, chemical plants, industrial services, and on marine installations. Also suitable for duties with water, condensate, alkalis, acids, solvents and most chemicals.

#### Chemical properties

Compatible with media in the range pH 0-14, excluding strong oxidising agents.

#### How supplied

All popular square sections from 3 mm ( $\frac{1}{8}$ " upwards in boxes containing 8 m (26' 3"), in coil form or on spools as detailed in the table below. Also supplied as split preformed rings and sets.

Spool ordering information			
Size		Packaged $\pm$ 10%	
mm	inch	kg	lbs
3.0	$\frac{1}{8}$	0.9	2
5.0	$\frac{3}{16}$	0.9	2
6.5	$\frac{1}{4}$	0.9	2
8.0	$\frac{5}{16}$	2.3	5
10.0	-	2.3	5
11.0	$\frac{7}{16}$	2.3	5
12.5	$\frac{1}{2}$	4.5	10
14.0	$\frac{9}{16}$	4.5	10
16.0	$\frac{5}{8}$	4.5	10
20.0	$\frac{13}{16}$	4.5	10
22.0	$\frac{7}{8}$	4.5	10
25.0	1	4.5	10

#### Notes:

\*Significantly higher, refer to James Walker.  
\*\*Refer to James Walker for higher pressures.



#### VALVE STEM DUTIES

Maximum Operating Temperatures:  
Steam

+550°C (+1022°F)

Oxidising conditions

+450°C (+842°F)

Minimum Operating Temperature:

-200°C (-328°F)

Maximum System Pressure:

30 MPa/300 bar (4351 psi)



#### VALVE STEM DUTIES

Maximum Operating Temperatures:  
Steam

+550°C (+1022°F)

Oxidising conditions

+550°C (+1022°F)

Non-oxidising\*

Minimum Operating Temperature:

-50°C (-58°F)

Maximum System Pressure:

15 MPa/150 bar  
(2175 psi) typical\*\*



# Lionpak<sup>®</sup> 5303

Carbon fibre strength  
with dry running capability

**Lionpak<sup>®</sup> 5303 is a tough, carbon fibre packing, thoroughly impregnated with James Walker's proprietary suspension to enhance sealability.**

This suspension is based on PTFE, high temperature lubricant and corrosion inhibitors.

**Prime features**

- Recommended for applications with corrosive chemicals.
- Tough carbon fibre construction capable of handling steam and operating on dry running shafts.
- Entrapping the suspension in a braided carbon fibre matrix provides a compression packing with excellent lubrication as well as superior blocking of body leakage.

**Typical applications**

Pumps, valves, and other static or dynamic equipment handling corrosive chemicals. Suitable for duties with steam and hot water, acids and alkalis, organic chemicals, dry powder and thermic fluids.

**Chemical properties**

Compatible with media in the range pH 0-14, excluding strong oxidising agents.

**How supplied**

All popular square sections from 3 mm to 50 mm (1/8" to 2") in boxes containing 8 m (26' 3"), in coil form or on spools as detailed in the table below. Also supplied as split preformed rings and sets.

Spool ordering information			
Size		Packaged ± 10%	
mm	inch	kg	lbs
3.0	1/8	0.9	2
5.0	3/16	0.9	2
6.5	1/4	0.9	2
8.0	5/16	2.3	5
10.0	-	2.3	5
11.0	7/16	2.3	5
12.5	1/2	4.5	10
14.0	9/16	4.5	10
16.0	5/8	4.5	10
20.0	13/16	4.5	10
22.0	7/8	4.5	10
25.0	1	4.5	10

**Notes:** \*May be suitable for higher pressures on certain reciprocating duties; please consult James Walker.



**VALVE STEM DUTIES**

Maximum Operating Temperature:  
+350°C (+662°F)

Minimum Operating Temperature:  
-50°C (-58°F)

Maximum System Pressure:  
20 MPa/200 bar (2900 psi)



**CENTRIFUGAL PUMPS AND ROTARY EQUIPMENT**

Maximum Operating Temperature:  
+350°C (+662°F)

Minimum Operating Temperature:  
-50°C (-58°F)

Maximum Shaft Speed:  
20 m/s (3937 fpm)

Maximum System Pressure:  
2 MPa/20 bar (290 psi)



**RECIPROCATING PUMPS AND RAMS**

Maximum Operating Temperature:  
+350°C (+662°F)

Minimum Operating Temperature:  
-50°C (-58°F)

Maximum Rod Speed:  
2.0 m/s (394 fpm)

Maximum System Pressure:  
15 MPa/150 bar (2175 psi)\*



# Lionpak<sup>®</sup> 5501/5503/5504

Graphite moulded rings  
with outstanding qualities

**Lionpak<sup>®</sup> graphite moulded rings are high-efficiency, moulded graphite sealing rings, produced to precise density and size. They are manufactured from expanded high purity flexible graphite foil with an oxidation inhibitor. They do not contain binders, elastomers or fillers.**

The difference between the three model numbers is the purity of the graphite foil from which the rings are manufactured.

**Prime features**

- Outstanding sealing performance over long adjustment-free periods.
- Excellent chemical resistance.
- Very wide temperature range.
- Lionpak<sup>®</sup> 5503 moulded rings conform to Shell material specification MESC SPE 85/203.

**Typical applications**

Valves and rotary equipment handling virtually any media. These rings are ideal for duties with high-temperature steam, demineralised water, heat transfer media, petroleum products, inorganic and organic acids, alkalis, hot waxes and oils.

**Material properties**

- Compatible with media in the range pH 0-14.
- Sulphur content (typical): ≤300 ppm.
- No loss of volatiles at high temperature.
- Lower limiting temperatures apply when used with oxidising agents, e.g. nitric acid.
- Thermal conductivity, ring of density 1.4g/cm<sup>3</sup>: (SG 1.4): axial: 400W/mK; radial: 6W/mK.
- Coefficient of friction to steel: 0.05.

**How supplied**

Precision moulded rings in endless form, or with single split or matched scarf-split halves. Sections 1.5 mm to 40 mm (1/16" to 1 9/16"); diameters 2 mm to 1200 mm (or 3/32" to 47 1/4").

	Lionpak <sup>®</sup> 5501	Lionpak <sup>®</sup> 5503	Lionpak <sup>®</sup> 5504
Graphite purity [%]	98	99	99.85
Ash content [%]	2	1	0.15
Density range [g/cm <sup>3</sup> /SG]	1.4 -1.8	1.4 -1.8	1.4 -1.8
Sulphur content [ppm]	≤300	≤300	≤300
Chloride content [ppm]	≤25	≤10	≤10
Fluoride content [ppm]	≤25	≤10	≤10
Halogen content [ppm]	≤100	≤50	≤50
Oxidation rate in air at 670°C (1238°F) [%/hour]	<5	<4	<4
Passive oxidation inhibitor	Yes	Yes	Yes



**VALVE STEM DUTIES**

Maximum Operating Temperatures:  
Steam

+650°C (+1202°F)

Oxidising conditions  
+500°C (+932°F)

Non-oxidising  
+1000°C (+1832°F)

Minimum Operating Temperature:  
-200°C (-328°F)

Maximum System Pressure:  
25 MPa/250 bar (3626 psi)



**CERTAIN ROTARY EQUIPMENT**

Consult James Walker for details.



**RECOMMENDED RING DENSITIES**

For valve stem duties:  
1.6 g/cm<sup>3</sup> (SG 1.6)

For rotary duties:  
1.5 g/cm<sup>3</sup> (SG 1.5)

For special applications:  
Mixture of ring densities

# Lionpak®

## 9100

Synthetic packing with  
silicone-free lubrication

Previously known as Fluolion® Emulsion XA-P



### VALVE STEM DUTIES

Maximum Operating Temperature:  
+270°C (+518°F)

Minimum Operating Temperature:  
-50°C (-58°F)

Maximum System Pressure:  
10 MPa/100 bar (1450 psi)



### CENTRIFUGAL PUMPS AND ROTARY EQUIPMENT

Maximum Operating Temperature:  
+270°C (+518°F)

Minimum Operating Temperature:  
-50°C (-58°F)

Maximum Shaft Speed:  
20 m/s (3937 fpm)

Maximum System Pressure:  
2.5 MPa/25 bar (363 psi)



### RECIPROCATING PUMPS AND RAMS

Maximum Operating Temperature:  
+270°C (+518°F)

Minimum Operating Temperature:  
-50°C (-58°F)

Maximum Rod Speed:  
1.0 m/s (197 fpm)

Maximum System Pressure:  
10 MPa/100 bar (1450 psi)

**Lionpak® 9100 is a universal packing comprising a unique synthetic yarn, densified with particles of PTFE and treated with an advanced silicone-free lubricant.**

The impregnated yarns are cross-plaited over an elastomeric core, which enables this packing to absorb the eccentric actions of worn shafts and bearings running in very harsh environments.

#### Prime features

- Excellent chemical resistance.
- Excellent abrasion resistance.
- Low friction and low wear on shaft sleeves.
- Contains non-contaminating lubricants.

#### Typical applications

Pumps, valves and rotating plant that handle hot, abrasive and highly caustic fluid media. This packing is widely used in contact with hot slurries and effluents at pulp and paper mills and alumina processing plants. It is also employed as a general purpose packing in the chemical industry.

#### Chemical properties

Compatible with media in the range pH 1-14.

#### How supplied

All popular square sections from 3 mm to 25 mm (1/8" to 1") in boxes containing 8 m (26' 3"), in coil form or on spools as detailed in the table below. Also supplied as split preformed rings and sets.

Spool ordering information			
Size		Packaged ± 10%	
mm	inch	kg	lbs
3.0	1/8	0.9	2
5.0	3/16	0.9	2
6.5	1/4	0.9	2
8.0	5/16	2.3	5
10.0	-	2.3	5
11.0	7/16	2.3	5
12.5	1/2	4.5	10
14.0	9/16	4.5	10
16.0	5/8	4.5	10
20.0	13/16	4.5	10
22.0	7/8	4.5	10
25.0	1	4.5	10

# Lionpak®

## 9101

Acrylic-based packing  
for general duties

**Lionpak® 9101 is an economical packing braided from strong acrylic fibre.**

It is impregnated with James Walker's proprietary PTFE-based dispersion.

#### Prime features

- Better mechanical strength than packings made of flax.
- Suitable for use on clean water duties.
- Easy to cut and fit; simple to remove.
- PTFE-based dispersion enhances chemical resistance and improves the density and sealing ability of the product.

#### Typical applications

Recommended as an economical general duty packing for valves, centrifugal pumps and rotary equipment. It is also ideal for static applications including tank lids, hatches and inspection covers. It is not suitable for reciprocating pumps or rams.

#### Chemical properties

Compatible with media in the range pH 2-12.

#### How supplied

All popular square sections from 3 mm to 50 mm (1/8" to 2") in boxes containing 8 m (26' 3"), in coil form or on spools as detailed in the table below. Also supplied as split preformed rings and sets.

Spool ordering information			
Size		Packaged ± 10%	
mm	inch	kg	lbs
3.0	1/8	0.9	2
5.0	3/16	0.9	2
6.5	1/4	0.9	2
8.0	5/16	0.9	2
10.0	-	2.3	5
11.0	7/16	2.3	5
12.5	1/2	2.3	5
14.0	9/16	2.3	5
16.0	5/8	4.5	10
20.0	13/16	4.5	10
22.0	7/8	4.5	10
25.0	1	4.5	10

Notes: \*Please consult James Walker.



### VALVE STEM DUTIES

Maximum Operating Temperature:  
+250°C (+482°F)

Minimum Operating Temperature:  
-50°C (-58°F)

Maximum System Pressure:  
10 MPa/100 bar (1450 psi)



### CENTRIFUGAL PUMPS AND ROTARY EQUIPMENT

Maximum Operating Temperature:  
+250°C (+482°F)

Minimum Operating Temperature:  
-50°C (-58°F)

Maximum Shaft Speed:  
10 m/s (1969 fpm)

Maximum System Pressure:  
2 MPa/20 bar (290 psi)



### STATIC DUTIES

Maximum Operating Temperature:  
+250°C (+482°F)

Minimum Operating Temperature:  
-50°C (-58°F)

Maximum Static Pressure:  
Dependent on application\*



# Lionpak<sup>®</sup>

## 9102

Acrylic-based packing for general duties

**Lionpak<sup>®</sup> 9102 is an economical packing braided from strong acrylic fibre.**

It is impregnated with James Walker's proprietary graphite-based dispersion.

**Prime features**

- Better mechanical strength than packings made of flax.
- Suitable for use on clean water duties.
- Easy to cut and fit; simple to remove.
- Graphite-based dispersion improves the density and sealing ability of the product.

**Typical applications**

Recommended as an economical general duty packing for valves, centrifugal pumps and rotary equipment. It is also ideal for static applications including tank lids, hatches and inspection covers. It is not suitable for reciprocating pumps or rams.

**Chemical properties**

Compatible with media in the range pH 2-12.

**How supplied**

All popular square sections from 3 mm to 50 mm (1/8" to 2") in boxes containing 8 m (26' 3"), in coil form or on spools as detailed in the table below. Also supplied as split preformed rings and sets.

Spool ordering information			
Size		Packaged ± 10%	
mm	inch	kg	lbs
3.0	1/8	0.9	2
5.0	3/16	0.9	2
6.5	1/4	0.9	2
8.0	5/16	0.9	2
10.0	-	2.3	5
11.0	7/16	2.3	5
12.5	1/2	2.3	5
14.0	9/16	2.3	5
16.0	5/8	4.5	10
20.0	13/16	4.5	10
22.0	7/8	4.5	10
25.0	1	4.5	10

Notes: \*Please consult James Walker.



**VALVE STEM DUTIES**

**Maximum Operating Temperature:**  
+250°C (+482°F)

**Minimum Operating Temperature:**  
-50°C (-58°F)

**Maximum System Pressure:**  
10 MPa/100 bar (1450 psi)



**CENTRIFUGAL PUMPS AND ROTARY EQUIPMENT**

**Maximum Operating Temperature:**  
+250°C (+482°F)

**Minimum Operating Temperature:**  
-50°C (-58°F)

**Maximum Shaft Speed:**  
10 m/s (1969 fpm)

**Maximum System Pressure:**  
2 MPa/20 bar (290 psi)



**STATIC DUTIES**

**Maximum Operating Temperature:**  
+250°C (+482°F)

**Minimum Operating Temperature:**  
-50°C (-58°F)

**Maximum Static Pressure:**  
Dependent on application\*



# Lionpak<sup>®</sup>

## 9500

Versatile natural yarn packing with PTFE lubrication

Previously known as Ramieux

**Lionpak<sup>®</sup> 9500 is a versatile, high-performance packing, cross-plaited from top quality bleached ramie fibre yarns that are impregnated with an advanced PTFE dispersion lubricant. The result is a consistent packing of uniform density and compressibility.**

Ramie, a tropical nettle plant, produces a fibre of extreme durability, rot resistance and significantly greater strength than flax, cotton or hemp.

**Prime features**

- Outstanding extrusion resistance.
- Outstanding abrasion resistance.
- Outstanding rot resistance.
- Low friction and low wear.
- Kind to shafts and sleeves.

**Typical applications**

Used with great success in the mining and quarrying industries on reciprocating pumps working at 30 MPa with water containing highly abrasive particles. Also used for water-based hydraulic systems, pulp and paper processing with cellulose slurry, brine circulation, cooling water systems, and with fluids that crystallise or contain suspended solids.

**Chemical properties**

Compatible with media in the range pH 4-11.

**How supplied**

All popular square sections from 3 mm to 25 mm (1/8" to 1") in boxes containing 8 m (26' 3"), in coil form or on spools as detailed in the table below. Also supplied as split preformed rings and sets.

Spool ordering information			
Size		Packaged ± 10%	
mm	inch	kg	lbs
3.0	1/8	0.9	2
5.0	3/16	0.9	2
6.5	1/4	0.9	2
8.0	5/16	2.3	5
10.0	-	2.3	5
11.0	7/16	2.3	5
12.5	1/2	4.5	10
14.0	9/16	4.5	10
16.0	5/8	4.5	10
20.0	13/16	4.5	10
22.0	7/8	4.5	10
25.0	1	4.5	10



**VALVE STEM DUTIES**

**Maximum Operating Temperature:**  
+120°C (+248°F)

**Minimum Operating Temperature:**  
-30°C (-22°F)

**Maximum System Pressure:**  
25 MPa/250 bar (3626 psi)



**CENTRIFUGAL PUMPS AND ROTARY EQUIPMENT**

**Maximum Operating Temperature:**  
+120°C (+248°F)

**Minimum Operating Temperature:**  
-30°C (-22°F)

**Maximum Shaft Speed:**  
17.5 m/s (3445 fpm)

**Maximum System Pressure:**  
2 MPa/20 bar (290 psi)



**RECIPROCATING PUMPS AND RAMS**

**Maximum Operating Temperature:**  
+120°C (+248°F)

**Minimum Operating Temperature:**  
-30°C (-22°F)

**Maximum Rod Speed:**  
2.0 m/s (394 fpm)

**Maximum System Pressure:**  
25 MPa/250 bar (3626 psi)



# Lionpak®

## 9501

Flax fibre with water compatibility  
for marine and general duties

**Lionpak® 9501 is a braided packing of tough flax fibre impregnated with James Walker's proprietary PTFE and oil-based dispersion.**

#### Prime features

- Economical packing of tough flax fibre construction.
- Recommended for water duties.
- Resistant to deformation.
- Lubrication package minimises scoring of sleeves and shafts.

#### Typical applications

This packing is highly compatible with water. It is recommended for duties with stern glands, rudder posts, water wheels, pumps and valves. Suitable for use with river water, sea water, surface water, waste water and sewage.

#### Chemical properties

Compatible with media in the range pH 5-10.

#### How supplied

All popular square sections from 3 mm to 50 mm (1/8" to 2") in boxes containing 8 m (26' 3"), in coil form or on spools as detailed in the table below. Also supplied as split preformed rings and sets.

Spool ordering information			
Size		Packaged ± 10%	
mm	inch	kg	lbs
3.0	1/8	0.9	2
5.0	3/16	0.9	2
6.5	1/4	0.9	2
8.0	5/16	0.9	2
10.0	-	2.3	5
11.0	7/16	2.3	5
12.5	1/2	2.3	5
14.0	9/16	2.3	5
16.0	5/8	4.5	10
20.0	13/16	4.5	10
22.0	7/8	4.5	10
25.0	1	4.5	10



#### VALVE STEM DUTIES

Maximum Operating Temperature:

+100°C (+212°F)

Minimum Operating Temperature:

-40°C (-40°F)

Maximum System Pressure:

10 MPa/100 bar (1450 psi)



#### CENTRIFUGAL PUMPS AND ROTARY EQUIPMENT

Maximum Operating Temperature:

+100°C (+212°F)

Minimum Operating Temperature:

-40°C (-40°F)

Maximum Shaft Speed:

3 m/s (591 fpm)

Maximum System Pressure:

1 MPa/10 bar (145 psi)



#### RECIPROCATING PUMPS AND RAMS

Maximum Operating Temperature:

+100°C (+212°F)

Minimum Operating Temperature:

-40°C (-40°F)

Maximum Rod Speed:

1.0 m/s (197 fpm)

Maximum System Pressure:

10 MPa/100 bar (1450 psi)



# Lionpak®

## 9600

Non-hazardous fibre packing for  
very high temperature applications

Previously known as Valcor® Hi-Temp

**Lionpak® 9600 is a compression packing for very high temperature duties.**

It is manufactured from an exceptionally stable fibre material that is soft, non-irritating, non-hazardous, and is not limited by World Health Organisation or European Union restrictions.

The yarn is spun into a flexible yarn and with low percentage of glass fibre and Inconel wire reinforcement. It contains no organic agent or processing additives. It therefore retains its physical and chemical properties at very high temperatures and does not decompose into hazardous substances.

#### Prime features

- Non-hazardous heat resistant fibre construction.
- Alternative for normal ceramic fibre packings.
- Good chemical compatibility.

#### Typical applications

Recommended for very high temperature static sealing duties or slow rotary applications. It replaces ceramic yarn packing and radiation seals on BOS plant, and ceramic packings and vessel lid seals on secondary steelmaking plant.

Other examples include door seals for annealing furnaces at steelworks, kiln packings, protective surfaces on pottery kiln cars, and stem gland sealing on valves handling very high temperature gases.

Other constructions include braided insulation sleeves, webbing tapes, ladder tapes, twisted ropes, lagging ropes, blankets and paper, and woven cloth.

#### Chemical properties

Compatible with media in the range pH 0-10, excluding hydrofluoric acid and hydrogen fluoride. It has excellent resistance to water, organic chemicals and other acids.

#### Health & Safety considerations

Average diameter of the mineral fibre used is 9µm (354µin), which is considered non-hazardous to health. No protection for breathing, eye, hand or body is required by the World Health Organisation or European Union during the product's normal storage, handling and use.

For further details please request a copy of our Safety Data Sheet (SDS). Please note that normal ceramic fibres, as often used in the manufacture of very high temperature compression packings, are around 3µm (118µin) in diameter. These much finer fibres are now considered hazardous to health, with WHO and EU restrictions applied to the products that contain them.

#### How supplied

Available as densely braided compression packings - square, round and rectangular - in sections from 5 mm to 100 mm (3/16" to 4"), and in any length in boxes containing 8 m (26' 3"), in coil form or on spools as detailed in the table below. Also supplied as split preformed rings and sets. Other constructions are manufactured to order.

Spool ordering information			
Size		Packaged ± 10%	
mm	inch	kg	lbs
5.0	3/16	0.9	2
6.5	1/4	0.9	2
8.0	5/16	2.3	5
10.0	-	2.3	5
11.0	7/16	2.3	5
12.5	1/2	2.3	5
14.0	9/16	2.3	5
16.0	5/8	4.5	10
20.0	13/16	4.5	10
22.0	7/8	4.5	10
25.0	1	4.5	10

**Notes:** Inconel® is a registered trademark of Special Metals Corporation.



#### STATIC AND SLOW ROTARY DUTIES ONLY

Maximum Operating Temperature (constant):

1000°C (1832°F)

Maximum Operating Temperature (intermittent):

1100°C (2012°F)

Minimum Working Temperature:

-50°C (-58°F)



# Lionpak®

## 9603

Mineral fibre for static sealing  
up to 550°C (1022°F) constant



### STATIC DUTIES

Maximum Operating Temperature (constant):  
+550°C (+1022°F)

Minimum Operating Temperature:  
-50°C (-58°F)

Maximum Static Pressure:  
Dependent on application\*

**Lionpak® 9603 is a dry braided packing of fibrous form, inorganic refractory oxides - silica fibre with no metallic content.**

#### Prime features

- Recommended for static use only.
- Thermally stable at high temperatures.

#### Typical applications

Static duties including furnace and oven doors, boiler doors, kilns, peep and inspection holes, flange grooves and steam exhaust pipes. Suitable for use with all non-oxidising liquids and gases, superheated steam and saturated steam, water, dyes and chemicals.

#### Chemical properties

Compatible with media in the range pH 0-13.

#### Health & Safety considerations

This product is manufactured from yarn that is excluded from classification as a carcinogen according to the criteria of note Q in European Directive 97/69/EC.

Average diameter of the mineral fibre used in Lionpak® 9603 is over 6µm (236µin), which is considered non-hazardous to health. No protection for breathing, eye, hand or body is required by the World Health Organisation or European Union for the material's normal handling, storage or use.

For further details please request a copy of our Safety Data Sheet (SDS).

Note that normal ceramic fibres, as often used in the manufacture of very high temperature compression packings, are around 3µm (118µin) in diameter. These much finer fibres are considered hazardous to health, with WHO and EU restrictions applied to the products that contain them.

#### How supplied

All popular square sections from 3 mm to 50 mm (1/8" to 2") in boxes containing 8 m (26' 3"), in coil form or on spools as detailed in the table below. Also supplied as split preformed rings and sets.

Spool ordering information			
Size		Packaged ± 10%	
mm	inch	kg	lbs
3.0	1/8	0.9	2
5.0	3/16	0.9	2
6.5	1/4	0.9	2
8.0	5/16	0.9	2
10.0	-	2.3	5
11.0	7/16	2.3	5
12.5	1/2	2.3	5
14.0	9/16	2.3	5
16.0	5/8	4.5	10
20.0	13/16	4.5	10
22.0	7/8	4.5	10
25.0	1	4.5	10

Notes: \*Please consult James Walker.

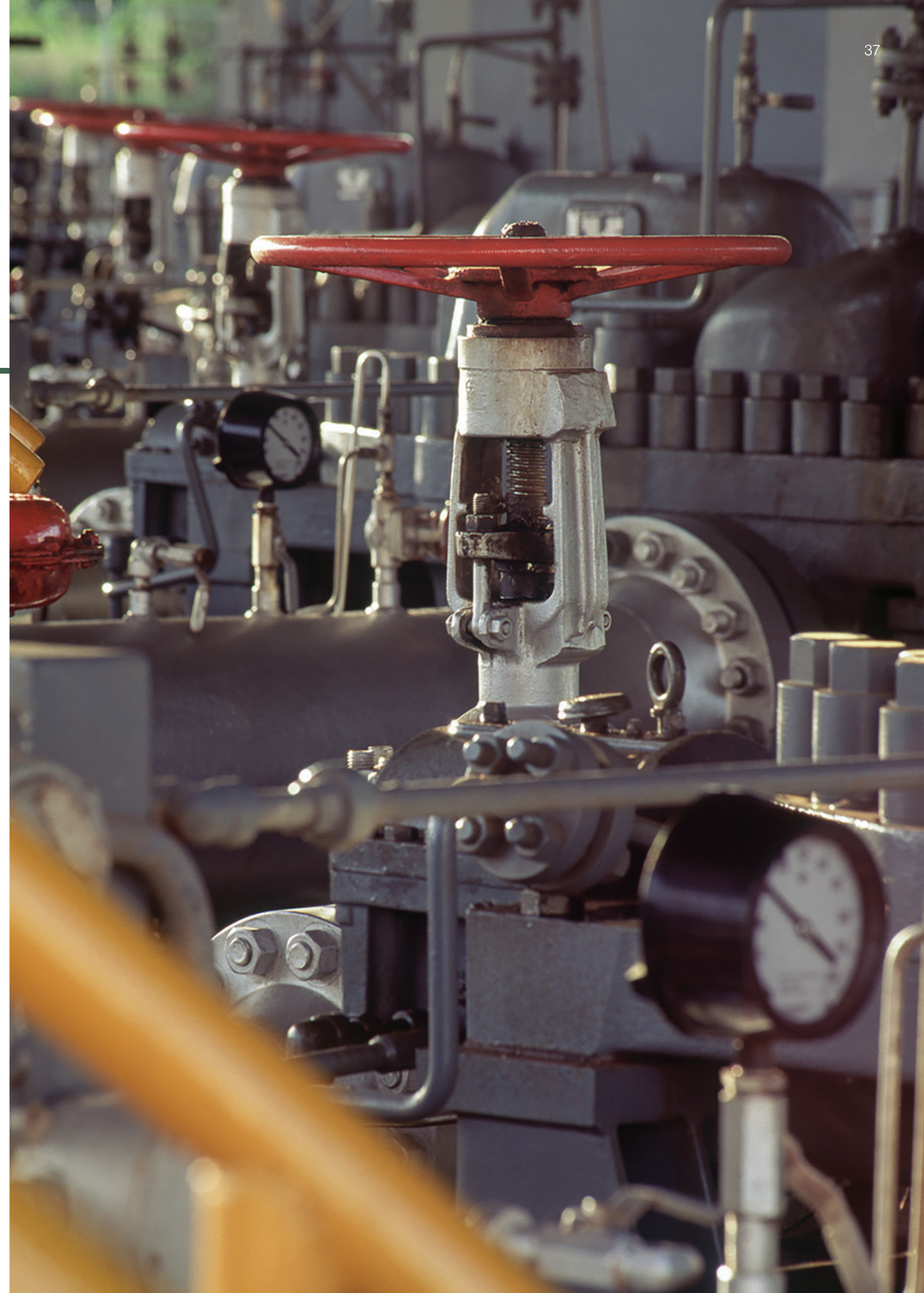

## Specialised Packings

Lionpak® specialised packings have been developed to meet the specific demands of particular applications or operating conditions.

### Page reference guide

<b>Lionpak®</b> 2102	39	<b>Lionpak®</b> 2504	44	<b>Lionpak®</b> 5301	49	<b>Lionpak®</b> 9602	54
<b>Lionpak®</b> 2202	40	<b>Lionpak®</b> 2505	45	<b>Lionpak®</b> 5302	50	<b>Lionpak®</b> 9605	55
<b>Lionpak®</b> 2303	41	<b>Lionpak®</b> 2506	46	<b>Lionpak®</b> 5304	51		
<b>Lionpak®</b> 2501	42	<b>Lionpak®</b> 3301	47	<b>Lionpak®</b> 5505	52		
<b>Lionpak®</b> 2502	43	<b>Lionpak®</b> 3302	48	<b>Lionpak®</b> 9601	53		

# Lionpak®

## 2102

FDA conforming expanded PTFE clean packing

**Lionpak® 2102 is a braided packing from high performance, pure and dry expanded PTFE yarn with highly refined mineral filler particles, which are non-toxic and contain no lubricants or additives.**

#### Prime features

- A dense, flexible and high purity packing with high cleanliness conforming to FDA and EU 1935/2004 standards.
- Excellent chemical resistance with a high degree of dimensional stability.
- Enhanced heat transfer properties.
- Highly conformable for ease of fitting and with very low coefficient of friction.
- Long life valve sealing with minimum maintenance.

#### Typical applications

Slow speed centrifugal and reciprocating pumps and other rotary equipment as well as different types of valve, in applications where hygiene and the low friction characteristics of pure PTFE are required. It is also suitable for use with potable water, foodstuffs and pharmaceutical products.

#### Chemical properties

Resistant to chemicals in the range pH 0-14, excluding strong oxidisers, molten alkali metals and fluorine compounds.

#### How supplied

All popular square sections from 3 mm to 25 mm (1/8" to 1") in boxes containing 8 m (26' 3"), or in coil form by the metre/foot or kilogram/pound. Also supplied as split preformed rings and sets.



### SPECIALISED PACKING



#### VALVE STEM DUTIES

**Maximum Operating Temperature:**  
+280°C (+536°F)  
**Minimum Operating Temperature:**  
-200°C (-328°F)  
**Maximum System Pressure:**  
25 MPa/250 bar (3626 psi)



#### CENTRIFUGAL PUMPS AND ROTARY EQUIPMENT

**Maximum Operating Temperature:**  
+280°C (+536°F)  
**Minimum Operating Temperature:**  
-200°C (-328°F)  
**Maximum Shaft Speed:**  
5 m/s (984 fpm)  
**Maximum System Pressure:**  
2 MPa/20 bar (290 psi)



#### RECIPROCATING PUMPS AND RAMS

**Maximum Operating Temperature:**  
+280°C (+536°F)  
**Minimum Operating Temperature:**  
-200°C (-328°F)  
**Maximum Rod Speed:**  
0.5 m/s (98 fpm)  
**Maximum System Pressure:**  
15 MPa/150 bar (2175 psi)

### APPROVALS



Conforms to;  
FDA 21 CFR 170.39  
EU regulation 1935/2004



# Lionpak®

## 2202

FDA conforming expanded PTFE clean packing

**Lionpak® 2202 is a diagonally braided packing from high performance, pure expanded PTFE yarn filled with highly refined mineral filler particles and treated with FDA-conforming mineral oil.**

#### Prime features

- A dense, flexible and high purity packing with high cleanliness conforming to FDA standards.
- Excellent chemical resistance with a high degree of dimensional stability.
- High performance sealing in valve and pump applications.
- Enhanced heat transfer properties.
- Highly conformable for ease of fitting and with very low coefficient of friction.
- Long and efficient working life with minimal shaft wear and maintenance issues.

#### Typical applications

Recommended for both static and dynamic operations with centrifugal and reciprocating pumps, valves, mixers, reactors, agitators, dryers and air compressors, in applications where hygiene and the low friction characteristics of pure PTFE are required. It is also suitable for use with potable water, foodstuffs and pharmaceutical products.

#### Chemical properties

Resistant to chemicals in the range pH 0-14, excluding strong oxidisers, molten alkali metals and fluorine compounds.

#### How supplied

All popular square sections from 3 mm to 25 mm (1/8" to 1") in boxes containing 8 m (26' 3"), or in coil form by the metre/foot or kilogram/pound. Also supplied as split preformed rings and sets.

#### SPECIALISED PACKING



#### VALVE STEM DUTIES

Maximum Operating Temperature:  
+280°C (+536°F)

Minimum Operating Temperature:  
-100°C (-148°F)

Maximum System Pressure:  
15 MPa/150 bar (2175 psi)



#### CENTRIFUGAL PUMPS AND ROTARY EQUIPMENT

Maximum Operating Temperature:  
+280°C (+536°F)

Minimum Operating Temperature:  
-100°C (-148°F)

Maximum Shaft Speed:  
12 m/s (2362 fpm)

Maximum System Pressure:  
2.5 MPa/25 bar (363 psi)



#### RECIPROCATING PUMPS AND RAMS

Maximum Operating Temperature:  
+280°C (+536°F)

Minimum Operating Temperature:  
-100°C (-148°F)

Maximum Rod Speed:  
1 m/s (197 fpm)

Maximum System Pressure:  
15 MPa/150 bar (2175 psi)

#### APPROVALS



Conforms to:  
FDA 21 CFR 170.39



# Lionpak®

## 2303

Reliable packing based on graphite and PTFE yarn with silicone-free lubrication

Previously known as Liongraf

**Lionpak® 2303 is a highly reliable pump and valve packing based on graphite and PTFE yarn that is thermally stabilised then lubricated with a silicone-free compound.**

Sections of 6.5 mm (1/4") square and above are of cross-plaited construction; sections below 6.5 mm are plaited.

#### Prime features

- Strong, durable and extrusion resistant.
- Reliable over a wide range of duties.
- Excellent chemical resistance.
- Low friction with high thermal conductivity.

#### Typical applications

Widely regarded as an economical packing for universal application and the reduction of stockholding requirements. Well proven in the petrochemical, power generation, marine and metallurgical sectors, and by pump and valve manufacturers for OEM installation. It is suitable for duties with steam, condensate, effluents, fuels and oils, acids, alkalis and chemical solutions.

#### Chemical properties

Compatible with media in the range pH 0-14, including corrosive fluids and solvents.

#### How supplied

All popular square sections from 3 mm to 25 mm (1/8" to 1") in boxes containing 8 m (26' 3"), in coil form or on spools as detailed in the table below. Also supplied as split preformed rings and sets.

Spool ordering information			
Size		Packaged ± 10%	
mm	inch	kg	lbs
3.0	1/8	0.9	2
5.0	3/16	0.9	2
6.5	1/4	0.9	2
8.0	5/16	2.3	5
10.0	-	2.3	5
11.0	7/16	2.3	5
12.5	1/2	4.5	10
14.0	9/16	4.5	10
16.0	5/8	4.5	10
20.0	13/16	4.5	10
22.0	7/8	4.5	10
25.0	1	4.5	10

#### SPECIALISED PACKING



#### VALVE STEM DUTIES

Maximum Operating Temperature:  
+260°C (+500°F)

Minimum Operating Temperature:  
-100°C (-148°F)

Maximum System Pressure:  
12 MPa/120 bar (1740 psi)



#### CENTRIFUGAL PUMPS AND ROTARY EQUIPMENT

Maximum Operating Temperature:  
+260°C (+500°F)

Minimum Operating Temperature:  
-100°C (-148°F)

Maximum Shaft Speed:  
17.5 m/s (3445 fpm)

Maximum System Pressure:  
2 MPa/20 bar (290 psi)



#### RECIPROCATING PUMPS AND RAMS

Maximum Operating Temperature:  
+260°C (+500°F)

Minimum Operating Temperature:  
-100°C (-148°F)

Maximum Rod Speed:  
2.0 m/s (394 fpm)

Maximum System Pressure:  
8 MPa/80 bar (1160 psi)



# Lionpak®

## 2501

PTFE/aramid for abrasion resistance with low friction

**Lionpak® 2501 is a dense braided combination packing, with tough aramid yarn at the corners, PTFE yarn at the faces, and a strong core of extruded and expanded PTFE cord.**

The aramid yarn is impregnated with an anti-friction fluoropolymer dispersion and a break-in lubricant, while the PTFE faces are treated with a high temperature resistant and inert lubricant.

#### Prime features

- Dense construction that offers excellent sealability.
- Aramid corners enhance long life in harsh plunger pump applications.
- Expanded PTFE core provides improved compressibility and responsiveness, compared to the aramid core typically used on similar products.
- PTFE faces provide low friction and low-wear running on shafts.

#### Typical applications

Centrifugal, reciprocating and plunger pumps (particularly dosing pumps), valves, reactors, autoclaves and agitators. It can also be used as a replacement for traditional lip seals in certain applications.

Suitable for use with ammonia, urea and carbamate condensate in fertiliser plant, pigments, dyestuffs, paints, amide, detergents, hydrazine, trisodium phosphate, sodium hexametaphosphate and slurries.

#### Chemical properties

Compatible with media in the range pH 1-13.

#### How supplied

All popular square sections from 6.5 mm to 50 mm (¼" to 2") in boxes containing 8 m (26' 3"), in coil form or on spools as detailed in the table below. Also supplied as split preformed rings and sets.

Spool ordering information			
Size		Packaged ± 10%	
mm	inch	kg	lbs
6.5	¼	0.9	2
8.0	5/16	0.9	2
10.0	-	2.3	5
11.0	7/16	2.3	5
12.5	½	2.3	5
14.0	9/16	2.3	5
16.0	5/8	4.5	10
20.0	13/16	4.5	10
22.0	7/8	4.5	10
25.0	1	4.5	10

#### SPECIALISED PACKING



#### VALVE STEM DUTIES

Maximum Operating Temperature:  
+250°C (+482°F)

Minimum Temperature:  
-50°C (-58°F)

Maximum System Pressure:  
25 MPa/250 bar (3626 psi)



#### CENTRIFUGAL PUMPS AND ROTARY EQUIPMENT

Maximum Operating Temperature:  
+250°C (+482°F)

Minimum Operating Temperature:  
-50°C (-58°F)

Maximum Shaft Speed:  
20 m/s (3937 fpm)

Maximum System Pressure:  
2 MPa/20 bar (290 psi)



#### RECIPROCATING PUMPS AND RAMS

Maximum Operating Temperature:  
+250°C (+482°F)

Minimum Operating Temperature:  
-50°C (-58°F)

Maximum Rod Speed:  
2.0 m/s (394 fpm)

Maximum System Pressure:  
10 MPa/100 bar (1450 psi)



# Lionpak®

## 2502

PTFE/graphite/aramid for abrasion resistance and cool running

**Lionpak® 2502 is a combination packing, with tough but smooth aramid fibre yarn at the corners, ePTFE/graphite fibre yarn at the faces, and a core of high density extruded and expanded PTFE cord.**

#### Prime features

- PTFE/graphite faces offer excellent heat dissipation for cool running.
- Aramid fibre corners withstand the rigours of plunger pump applications.
- Aramid yarn is impregnated with fluoropolymer dispersion to enhance sealability, and a break-in lubricant to reduce friction.
- PTFE core provides resistance to high working pressure.

#### Typical applications

With its dense construction and excellent sealability, this packing is used for chemical processing duties with pumps, valves, reactors, autoclaves, agitators and mixers.

It is suitable for use with ammonia and carbamate solutions, hydrazine, trisodium phosphate, sodium hexametaphosphate, black and green liquor, chemical slurries, paper pulp, contaminated water and molasses.

#### Chemical properties

Compatible with media in the range pH 1-13.

#### How supplied

All popular square sections from 6.5 mm to 50 mm (¼" to 2") in boxes containing 8 m (26' 3"), in coil form or on spools as detailed in the table below. Also supplied as split preformed rings and sets.

Spool ordering information			
Size		Packaged ± 10%	
mm	inch	kg	lbs
6.5	¼	0.9	2
8.0	5/16	0.9	2
10.0	-	2.3	5
11.0	7/16	2.3	5
12.5	½	2.3	5
14.0	9/16	2.3	5
16.0	5/8	4.5	10
20.0	13/16	4.5	10
22.0	7/8	4.5	10
25.0	1	4.5	10

**Notes:** \*Product also available with aramid core for higher pressure duties such as reciprocating pumps.

#### SPECIALISED PACKING



#### VALVE STEM DUTIES

Maximum Operating Temperature:  
+250°C (+482°F)

Minimum Operating Temperature:  
-50°C (-58°F)

Maximum System Pressure:  
25 MPa/250 bar (3626 psi)



#### CENTRIFUGAL PUMPS AND ROTARY EQUIPMENT

Maximum Operating Temperature:  
+250°C (+482°F)

Minimum Operating Temperature:  
-50°C (-58°F)

Maximum Shaft Speed:  
20 m/s (3937 fpm)

Maximum System Pressure:  
2 MPa/20 bar (290 psi)



#### RECIPROCATING PUMPS AND RAMS

Maximum Operating Temperature:  
+250°C (+482°F)

Minimum Operating Temperature:  
-50°C (-58°F)

Maximum Rod Speed:  
2.0 m/s (394 fpm)

Maximum System Pressure:  
20 MPa/200 bar (2900 psi)



# Lionpak<sup>®</sup>

## 2504

PTFE/graphite/fluoropolymer  
for industrial water duties

### SPECIALISED PACKING



#### VALVE STEM DUTIES

Maximum Operating Temperature:

+250°C (+482°F)

Minimum Temperature:

-100°C (-148°F)

Maximum System Pressure:

25 MPa/250 bar (3626 psi)



#### CENTRIFUGAL PUMPS AND ROTARY EQUIPMENT

Maximum Operating Temperature:

+250°C (+482°F)

Minimum Temperature:

-100°C (-148°F)

Maximum Shaft Speed:

20 m/s (3937 fpm)

Maximum System Pressure:

2 MPa/20 bar (290 psi)



#### RECIPROCATING PUMPS AND RAMS

Maximum Operating Temperature:

+250°C (+482°F)

Minimum Temperature:

-100°C (-148°F)

Maximum Rod Speed:

2.0 m/s (394 fpm)

Maximum System Pressure:

10 MPa/100 bar (1450 psi)



# Lionpak<sup>®</sup>

## 2505

PTFE/carbon yarn packing for  
frequently operated control valves

### SPECIALISED PACKING



#### VALVE STEM DUTIES

Maximum Operating Temperature:

+260°C (+500°F)

Minimum Temperature:

-200°C (-328°F)

Maximum System Pressure:

30 MPa/300 bar (4351 psi)

Lionpak<sup>®</sup> 2504 is a combination, duplex-braided packing, comprising red fluoropolymer-based yarn and expanded PTFE intimately bonded with graphite yarn.

#### Prime features

- A dense packing with a high degree of resilience, incorporating a break-in lubricant.
- Both yarns are highly lubricated during manufacture; the red fluoropolymer-based yarn releases lubricant on inside diameter when packing is bent around the shaft.
- This lubrication system provides very smooth start-up for pumps, plus long service life with low friction properties to safeguard shafts and sleeves from wear.
- Graphite content aids heat dissipation to further extend the service life.

#### Typical applications

Dynamic and static duties, including pumps, valves, mixers and reactors, across many industrial sectors. It is recommended for cooling water pumps and condensate extraction systems. Also suitable for use with demineralised water, raw water, hydrocarbons, paints, synthetic resins, emulsions, viscous slurries, and many other general industrial media.

#### Chemical properties

Compatible with media in the range pH 3-14.

#### How supplied

All popular square sections from 3 mm to 50 mm (1/8" to 2") in boxes containing 8 m (26' 3"), in coil form or on spools as detailed in the table below. Also supplied as split preformed rings and sets.

Spool ordering information			
Size		Packaged ± 10%	
mm	inch	kg	lbs
3.0	1/8	0.9	2
5.0	3/16	0.9	2
6.5	1/4	0.9	2
8.0	5/16	0.9	2
10.0	-	2.3	5
11.0	7/16	2.3	5
12.5	1/2	2.3	5
14.0	9/16	2.3	5
16.0	5/8	4.5	10
20.0	13/16	4.5	10
22.0	7/8	4.5	10
25.0	1	4.5	10

Lionpak<sup>®</sup> 2505 is a state-of-the-art gland packing especially developed for hard-working control valves.

This packing operates efficiently under arduous operating conditions where high resilience, high mechanical strength and high tensile strength are required.

The core of the packing is high strength carbon yarn, heavily lubricated with a special fluoropolymer dispersion and also treated with an inorganic passive corrosion inhibitor. The outer jacket is braided from pure PTFE yarn, lubricated with a PTFE suspensoid.

#### Prime features

- Construction provides optimum leakage control in hard-working control valves.
- Mechanically and thermally stable.
- Very high recovery factor.
- PTFE suspensoid acts as a blocking agent.
- Dissipates heat without chemical hardening.
- Easy to install, with smooth removal at shutdown.

#### Typical applications

Control valves and plug valves - especially those that are frequently operated.

Suitable for use with hydrocarbons, petrochemicals, superheated steam, saturated steam, organic/inorganic chemicals, acids and alkalis, solvents, amides, fuel oil, lubricating oil, dyestuffs, paints, and synthetic resins.

#### Chemical properties

Compatible with media in the range pH 0-14, excluding strong oxidising agents.

#### How supplied

All popular square sections from 6.5 mm to 50 mm (1/4" to 2") in boxes containing 8 m (26' 3"), in coil form or on spools as detailed in the table below. Also supplied as split preformed rings and sets.

Spool ordering information			
Size		Packaged ± 10%	
mm	inch	kg	lbs
6.5	1/4	0.9	2
8.0	5/16	0.9	2
10.0	-	2.3	5
11.0	7/16	2.3	5
12.5	1/2	2.3	5
14.0	9/16	2.3	5
16.0	5/8	4.5	10
20.0	13/16	4.5	10
22.0	7/8	4.5	10
25.0	1	4.5	10



# Lionpak®

## 2506

PTFE/graphite & carbon for excellent abrasion & chemical resistance

**Lionpak® 2506 is an enhanced braided packing of expanded PTFE with high quality graphite entrapped in the porous structure of the PTFE resin and with tough carbon fibres at the corners to resist abrasion with minimal shaft wear.**

The product is further lubricated with molybdenum disulphide (MoS<sub>2</sub>).

#### Prime features

- A dense packing offering a high degree of dimensional stability.
- The graphite provides heat dissipation to enhance the product's long and efficient working life, which is also improved by the excellent thermal conductivity of molybdenum disulphide.
- Molybdenum disulphide provides good chemical resistance and enhances high speed rotary operations by minimising friction and wear.
- The carbon fibre at the corners provides excellent abrasion resistance particularly in chemical slurries.
- The product construction enables the packing to safeguard shaft/shaft sleeves from wear and erosion.

#### Typical applications

Centrifugal and reciprocating pumps, valves, large diameter shafts, reactor vessels, agitators, mixers and autoclaves. Suitable for duties with acids and alkalis of any concentration, phosphoric acid, hydrocarbons, solvents, raw water, demineralised water, condensate and cooling water. Also suitable for all types of slurries particularly chemical slurries, effluent, sewage as well as caustic and industrial water.

#### Chemical properties

Resistant to chemicals in the range pH 0-14, excluding strong oxidisers, molten alkali metals and fluorine compounds.

#### How supplied

All popular square sections from 6.5 mm to 50 mm (¼" to 2") in boxes containing 8 m (26' 3"), in coil form or on spools as detailed in the table below. Also supplied as split preformed rings and sets.

Spool ordering information			
Size		Packaged ± 10%	
mm	inch	kg	lbs
6.5	¼	0.9	2
8.0	5/16	2.3	5
10.0	-	2.3	5
11.0	7/16	2.3	5
12.5	½	4.5	10
14.0	9/16	4.5	10
16.0	5/8	4.5	10
20.0	13/16	4.5	10
22.0	7/8	4.5	10
25.0	1	4.5	10

#### SPECIALISED PACKING



#### VALVE STEM DUTIES

Maximum Operating Temperature:  
+260°C (+500°F)

Minimum Operating Temperature:  
-100°C (-148°F)

Maximum System Pressure:  
25 MPa/250 bar (3626 psi)



#### CENTRIFUGAL PUMPS AND ROTARY EQUIPMENT

Maximum Operating Temperature:  
+260°C (+500°F)

Minimum Operating Temperature:  
-100°C (-148°F)

Maximum Shaft Speed:  
22 m/s (4331 fpm)  
Maximum System Pressure:  
2 MPa/20 bar (290 psi)



#### RECIPROCATING PUMPS AND RAMS

Maximum Operating Temperature:  
+260°C (+500°F)

Minimum Operating Temperature:  
-100°C (-148°F)

Maximum Rod Speed:  
2.0 m/s (394 fpm)  
Maximum System Pressure:  
10 MPa/100 bar (1450 psi)



# Lionpak®

## 3301

Aramid/fluoropolymer for abrasion resistance and minimal shaft wear

**Lionpak® 3301 comprises tough aramid fibre yarn over a core of red fluoropolymer-based yarn.**

The aramid fibre yarn is thoroughly impregnated with James Walker's proprietary PTFE-based dispersion. The packing is further impregnated with break-in lubricant, and a surface run-in lubricant.

#### Prime features

- Excellent abrasion resistance and corrosion resistance.
- Tough aramid construction provides dimensional stability and resistance to deformation on arduous duties.
- The red fluoropolymer-based yarn used in the core releases lubricant on its inside diameter when packing is bent around the shaft; this provides excellent lubrication throughout the service life of the packing.

#### Typical applications

Recommended for equipment handling metallic slurries and ash slurries at metallurgical plant, including pumps, valves, mixers, reactors, clinker grinders, agitators, extruders, rotary vacuum driers, autoclaves and door seals. This product is also recommended for marine use on propulsion lines and stern glands.

Suitable for use with turbid saline water, sea water, surface water, ash slurry, iron slurry, paper pulp, pulp with water, chemical slurries, powdered chemicals, coolant, coal dust, crude oil and fuel oil.

#### Chemical properties

Compatible with media in the range pH 1-13.

#### How supplied

All popular square sections from 6.5 mm to 50 mm (¼" to 2") in boxes containing 8 m (26' 3"), in coil form or on spools as detailed in the table below. Also supplied as split preformed rings and sets.

Spool ordering information			
Size		Packaged ± 10%	
mm	inch	kg	lbs
6.5	¼	0.9	2
8.0	5/16	2.3	5
10.0	-	2.3	5
11.0	7/16	2.3	5
12.5	½	4.5	10
14.0	9/16	4.5	10
16.0	5/8	4.5	10
20.0	13/16	4.5	10
22.0	7/8	4.5	10
25.0	1	4.5	10

#### SPECIALISED PACKING



#### VALVE STEM DUTIES

Maximum Operating Temperature:  
+250°C (+482°F)

Minimum Temperature:  
-50°C (-58°F)

Maximum System Pressure:  
15 MPa/150 bar (2175 psi)



#### CENTRIFUGAL PUMPS AND ROTARY EQUIPMENT

Maximum Operating Temperature:  
+250°C (+482°F)

Minimum Operating Temperature:  
-50°C (-58°F)

Maximum Shaft Speed:  
20 m/s (3937 fpm)  
Maximum System Pressure:  
2.5 MPa/25 bar (363 psi)



#### RECIPROCATING PUMPS AND RAMS

Maximum Operating Temperature:  
+250°C (+482°F)

Minimum Operating Temperature:  
-50°C (-58°F)

Maximum Rod Speed:  
1.5 m/s (295 fpm)  
Maximum System Pressure:  
15 MPa/150 bar (2175 psi)

# Lionpak®

## 3302

High performance abrasion-resistant  
'white' packing  
Previously known as Arasele®

**Lionpak® 3302 is a high performance abrasion-resistant 'white' gland packing offering minimal wear, braided from fine yarns of tough synthetic polymer fibre.**

The yarns are texturised and impregnated uniformly and deeply with PTFE dispersion to a high concentration, before being braided over a central core of temperature resistant white elastomer.

A silicone-free, inert and colourless lubricant is incorporated during the manufacturing process to provide swift and easy running-in on dynamic duties.

#### Prime features

- Kinder to shafts than traditional 'yellow' packings.
- Can eliminate unnecessary wear under adverse operating conditions.
- Excellent resistance to chemical and abrasive media.
- Resists hydrolysis - ideal for steam, water and hot aqueous solutions.
- Better thermal conductivity than most 'white' or 'yellow' packings.
- Can absorb eccentric shaft/ram actions and thermal/pressure shocks and cycling.

#### Typical applications

Gland sealing on rotary or reciprocating pumps and valves that handle highly abrasive slurries or aggressive chemical solutions in the mineral, pulp and paper, wastewater and chemical processing industries.

It is also recommended for water, aqueous solutions and other media in processes where a clean white, non-staining gland packing is required.

Proves particularly effective in applications where its rubber core enables the packing to absorb the eccentric movement of shafts or rams that run out-of-true. Its construction can also provide the packing with swift recovery from thermal or pressure shocks and cycling.

#### Chemical properties

Compatible with media in the range pH 0-13, including steam, water, fuels, oils, solvents, acids and alkalis.

Note: this chemical resistance is better than that of traditional aramid-based packings.

#### How supplied

All popular square sections from 3 to 25 mm ( $\frac{1}{8}$ " to 1") in boxes containing 8 m (26' 3"), in coil form or on spools as detailed in the table below. Also supplied as split preformed rings and sets.

Spool ordering information			
Size		Packaged $\pm$ 10%	
mm	inch	kg	lbs
3.0	$\frac{1}{8}$	0.9	2
5.0	$\frac{3}{16}$	0.9	2
6.5	$\frac{1}{4}$	0.9	2
8.0	$\frac{5}{16}$	2.3	5
10.0	-	2.3	5
11.0	$\frac{7}{16}$	2.3	5
12.5	$\frac{1}{2}$	4.5	10
14.0	$\frac{9}{16}$	4.5	10
16.0	$\frac{5}{8}$	4.5	10
20.0	$1\frac{3}{16}$	4.5	10
22.0	$\frac{7}{8}$	4.5	10
25.0	1	4.5	10

**Notes:** \*Traditional aramid-based packings typically work at a maximum operating temperature of +250°C (+482°F).

# Lionpak®

## 5301

Carbon fibre strength with  
low friction and heat dissipation

**Lionpak® 5301 is inter-braided from carbon fibre yarn.**

It is impregnated with James Walker's proprietary graphite-based dispersion as a blocking agent, and a molybdenum based corrosion inhibitor.

#### Prime features

- Strong, pliable and abrasion resistant.
- Excellent heat dissipation and low friction qualities.
- Inter-braiding plus blocking agent ensures leak-free construction.
- Corrosion inhibitor prevents galvanic corrosion when used on applications with steam.

#### Typical applications

Valves, pumps, mixers, reactors and agitators, handling steam, acids, alkalis, solvents, organic chemicals, gases and thermic fluids such as molten salt.

#### Chemical properties

Compatible with media in the range pH 0-14, excluding strong oxidising agents.

#### How supplied

All popular square sections from 3 mm to 50 mm ( $\frac{1}{8}$ " to 2") in boxes containing 8 m (26' 3"), in coil form or on spools as detailed in the table below. Also supplied as split preformed rings and sets.

Spool ordering information			
Size		Packaged $\pm$ 10%	
mm	inch	kg	lbs
3.0	$\frac{1}{8}$	0.9	2
5.0	$\frac{3}{16}$	0.9	2
6.5	$\frac{1}{4}$	0.9	2
8.0	$\frac{5}{16}$	0.9	2
10.0	-	2.3	5
11.0	$\frac{7}{16}$	2.3	5
12.5	$\frac{1}{2}$	2.3	5
14.0	$\frac{9}{16}$	2.3	5
16.0	$\frac{5}{8}$	4.5	10
20.0	$1\frac{3}{16}$	4.5	10
22.0	$\frac{7}{8}$	4.5	10
25.0	1	4.5	10

**Notes:** \*May be suitable for higher pressures on certain reciprocating duties; please consult James Walker.

### SPECIALISED PACKING



#### VALVE STEM DUTIES

Maximum Operating Temperature:

+285°C (+545°F)\*

Minimum Operating Temperature:

-50°C (-58°F)

Maximum System Pressure:

15 MPa/150 bar (2175 psi)



#### CENTRIFUGAL PUMPS AND ROTARY EQUIPMENT

Maximum Operating Temperature:

+285°C (+545°F)\*

Minimum Operating Temperature:

-50°C (-58°F)

Maximum Shaft Speed:

20 m/s (3937 fpm)

Maximum System Pressure:

2.5 MPa/25 bar (363 psi)



#### RECIPROCATING PUMPS AND RAMS

Maximum Operating Temperature:

+285°C (+545°F)\*

Minimum Operating Temperature:

-50°C (-58°F)

Maximum Rod Speed:

1.5 m/s (295 fpm)

Maximum System Pressure:

10 MPa/100 bar (1450 psi)



### SPECIALISED PACKING



#### VALVE STEM DUTIES

Maximum Operating Temperature:

+450°C (+842°F)

Minimum Temperature:

-50°C (-58°F)

Maximum System Pressure:

20 MPa/200 bar (2900 psi)



#### CENTRIFUGAL PUMPS AND ROTARY EQUIPMENT

Maximum Operating Temperature:

+450°C (+842°F)

Minimum Operating Temperature:

-50°C (-58°F)

Maximum Shaft Speed:

20 m/s (3937 fpm)

Maximum System Pressure:

2 MPa/20 bar (290 psi)



#### RECIPROCATING PUMPS AND RAMS

Maximum Operating Temperature:

+450°C (+842°F)

Minimum Operating Temperature:

-50°C (-58°F)

Maximum Rod Speed:

2.0 m/s (394 fpm)

Maximum System Pressure:

15 MPa/150 bar (2175 psi)\*



# Lionpak®

## 5302

Graphite/carbon fibre for chemical and abrasion resistance

**Lionpak® 5302 is a specially developed packing that combines the advantages of soft expanded high purity 99% graphite yarn with the toughness of carbon fibre yarn at its four corners.**

It is impregnated with James Walker's proprietary, high temperature, graphite-based dispersion and an inorganic passive corrosion inhibitor.

#### Prime features

- Recommended for applications at high working temperatures with corrosive media.
- Good resistance to abrasion and wear.
- Excellent dry-running capabilities that reduce the need for continuous water flushing.
- Readily adapts to worn/pitted surfaces for smooth running under adverse mechanical conditions.
- Corrosion inhibitor safeguards metallic interfaces from galvanic corrosion.

#### Typical applications

Pumps, valves, autoclaves, converters, mixers and reactors. Suitable for duties with steam, acids and alkalis, hydrocarbons, fuel and lubricating oils, FCC catalyst and bottom slurry, hydrogen sulphide, sulphur dioxide, thermic fluid, and abrasive media such as ash slurry, fly ash water and sea water.

#### Chemical properties

Compatible with media in the range pH 0-14, excluding strong oxidising agents.

#### How supplied

All popular square sections from 6.5 mm to 50 mm (¼" to 2") in boxes containing 8 m (26' 3"), in coil form or on spools as detailed in the table below. Also supplied as split preformed rings and sets.

Spool ordering information			
Size		Packaged ± 10%	
mm	inch	kg	lbs
6.5	¼	0.9	2
8.0	5/16	0.9	2
10.0	-	2.3	5
11.0	7/16	2.3	5
12.5	½	2.3	5
14.0	9/16	2.3	5
16.0	5/8	4.5	10
20.0	13/16	4.5	10
22.0	7/8	4.5	10
25.0	1	4.5	10

#### SPECIALISED PACKING



#### VALVE STEM DUTIES

Maximum Operating Temperature:

+450°C (+842°F)

Minimum Temperature:

-50°C (-58°F)

Maximum System Pressure:

25 MPa/250 bar (3626 psi)



#### CENTRIFUGAL PUMPS AND ROTARY EQUIPMENT

Maximum Operating Temperature:

+450°C (+842°F)

Minimum Operating Temperature:

-50°C (-58°F)

Maximum Shaft Speed:

20 m/s (3937 fpm)

Maximum System Pressure:

2 MPa/20 bar (290 psi)



#### RECIPROCATING PUMPS AND RAMS

Maximum Operating Temperature:

+450°C (+842°F)

Minimum Operating Temperature:

-50°C (-58°F)

Maximum Rod Speed:

2.0 m/s (394 fpm)

Maximum System Pressure:

10 MPa/100 bar (1450 psi)



# Lionpak®

## 5304

Carbon fibre for chemical resistance and low friction

**Lionpak® 5304 is a high grade packing of interlock-braided carbon fibre coated in PTFE.**

The packing is thoroughly impregnated with James Walker's proprietary suspension to enhance sealability. This suspension is based on graphite, high temperature lubricant and corrosion inhibitors.

#### Prime features

- Tough carbon fibre construction capable of handling steam, as well as the highly corrosive chemicals and abrasive media used in metallurgical processing plant.
- Entrapping the suspension in a braided carbon fibre matrix increases lubrication as well as acting as a blocking agent.
- Corrosion inhibitor safeguards metallic interfaces from galvanic corrosion.

#### Typical applications

Pumps, valves, reactors, agitators, mixers and other static or dynamic equipment in metallurgical processing and general industry. Suitable for duties with steam and hot water, caustic chemicals (such as sodium hydroxide, potassium nitride, etc), acids and alkalis, organic chemicals, dry powder and thermic fluids.

#### Chemical properties

Compatible with media in the range pH 0-14, excluding strong oxidising agents.

#### How supplied

All popular square sections from 3 mm to 50 mm (1/8" to 2") in boxes containing 8 m (26' 3"), in coil form or on spools as detailed in the table below. Also supplied as split preformed rings and sets.

Spool ordering information			
Size		Packaged ± 10%	
mm	inch	kg	lbs
3.0	1/8	0.9	2
5.0	3/16	0.9	2
6.5	¼	0.9	2
8.0	5/16	0.9	2
10.0	-	2.3	5
11.0	7/16	2.3	5
12.5	½	2.3	5
14.0	9/16	2.3	5
16.0	5/8	4.5	10
20.0	13/16	4.5	10
22.0	7/8	4.5	10
25.0	1	4.5	10

Notes: \*May be suitable for higher pressures on certain reciprocating duties; please consult James Walker.

#### SPECIALISED PACKING



#### VALVE STEM DUTIES

Maximum Operating Temperature:

+260°C (+500°F)

Minimum Temperature:

-100°C (-148°F)

Maximum System Pressure:

20 MPa/200 bar (2900 psi)



#### CENTRIFUGAL PUMPS AND ROTARY EQUIPMENT

Maximum Operating Temperature:

+260°C (+500°F)

Minimum Operating Temperature:

-100°C (-148°F)

Maximum Shaft Speed:

20 m/s (3937 fpm)

Maximum System Pressure:

2 MPa/20 bar (290 psi)



#### RECIPROCATING PUMPS AND RAMS

Maximum Operating Temperature:

+260°C (+500°F)

Minimum Operating Temperature:

-100°C (-148°F)

Maximum Rod Speed:

2.0 m/s (394 fpm)

Maximum System Pressure:

15 MPa/150 bar (2175 psi)\*

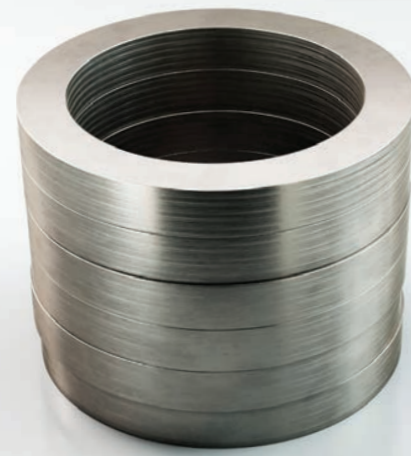

# Lionpak®

## 5505

Low friction rings for  
low-torque valve operation

Previously known as Supagraf® LF rings

### SPECIALISED PACKING



#### VALVE STEM DUTIES

Maximum Operating Temperature:

+350°C (+662°F)

Minimum Temperature:

-200°C (-328°F)

Maximum System Pressure:

25 MPa/250 bar (3626 psi)

**Lionpak® graphite moulded rings represent a major enhancement to the operational capabilities of graphite sealing rings used on valve stems.**

The rings are precision moulded from high purity expanded graphite foil to which a special low friction coating has been sinter bonded. This 5µm thick coating is sinter bonded to the expanded graphite before the moulding process to ensure maximum service life.

#### Prime features

- Greatly reduces the torque needed for efficient valve action.
- Saves on power consumption and enables smaller actuators to be used.
- Lowers the break-out friction for smoother valve operation.
- Retains exceptionally low friction characteristics for up to 20,000 valve cycles.
- Subsequent manual adjustment extends performance to 60,000 cycles.
- Fire-safe capability enables rings to be used in plant subjected to fire rating tests.

Graphite purity [%]	98
Ash content [%]	2
Density range [g/cm <sup>3</sup> /SG]	1.4-1.8
Sulphur content [ppm]	≤300
Chloride content [ppm]	≤25
Fluoride content [ppm]	≤25
Halogen content [ppm]	≤100
Oxidation rate in air at 670°C (1238°F) [%/hour]	<5
Passive corrosion inhibitor	Yes

#### Typical applications

- Valves that handle dry gases and other fluids, where friction on standard graphite seals is unacceptably high.
- Valves that suffer judder, hesitation or erratic action due to carbon pick-up or high-spot friction on the spindle.

#### Material properties

- Compatible with media in the range pH 0-14.
- Sulphur content (typical): ≤300 ppm.
- No loss of volatiles at high temperature.
- Lower limiting temperatures apply when used with oxidising agents, e.g. nitric acid.

In comparative tests, sets of Lionpak® 5505 displayed exactly half the friction coefficient of standard graphite and provided a continued low friction performance over more than 300 cycles.

#### How supplied

Precision moulded rings in endless form, or with single split or matched scarf-split halves. Sections 1.5 mm to 40 mm ( $\frac{1}{16}$ " to  $1\frac{3}{16}$ "); diameters 2 mm to 1200 mm (or  $\frac{3}{32}$ " to  $47\frac{1}{4}$ ").

# Lionpak®

## 9601

Mineral fibre for static sealing duties  
up to 1000°C (1832°F) constant



### SPECIALISED PACKING



#### STATIC DUTIES

Maximum Operating Temperature:  
Constant

+1000°C (+1832°F)

Intermittent

+1100°C (+2012°F)

Minimum Temperature:

-50°C (-58°F)

Maximum Static Pressure:

Dependent on application\*

**Lionpak® 9601 is a special high-temperature compression packing for static duties.**

It is manufactured from fibrous form of silica fibre with no metallic or ceramic content and impregnated with high-temperature resistant additives as well as graphite based dispersion.

#### Prime features

- Flexible packing that adapts well to groove corners: readily forms a circular section when required.
- Ideal for application with knife edge gate valves.
- Wear resistant with dry and hot abrasive slurries.
- Graphite-based dispersion improves lubrication and also acts as a blocking agent to prevent leakage.
- Resistant to high temperatures.

#### Typical applications

Recommended for autoclaves, converters and furnace doors. It can also be used on knife edge gate valves (valve bonnet sealing). Suitable for duties with ash slurries, chemical slurries, hot air, dry gases, superheated steam and saturated steam. This product may also be suitable for use on valves and pumps in certain applications; please consult James Walker.

#### Chemical properties

Compatible with media in the range pH 6-10.

#### Health & Safety considerations

Average diameter of the mineral fibre used is over 6µm (236µin), which is considered non-hazardous to health. No protection for breathing, eye, hand or body is required by the World Health Organisation or European Union for the material's normal handling, storage or use.

For further details please request a copy of our Safety Data Sheet (SDS).

Note that normal ceramic fibres, as often used in the manufacture of very high temperature compression packings, are around 3µm (118µin) in diameter. These much finer fibres are considered hazardous to health, with WHO and EU restrictions applied to the products that contain them.

#### How supplied

All popular square sections from 3 mm to 50 mm ( $\frac{1}{8}$ " to 2") in boxes containing 8 m (26' 3"), in coil form or on spools as detailed in the table below. Also supplied as split preformed rings and sets.

Spool ordering information			
mm	inch	Packaged ± 10%	
		kg	lbs
3.0	$\frac{1}{8}$	0.9	2
5.0	$\frac{3}{16}$	0.9	2
6.5	$\frac{1}{4}$	0.9	2
8.0	$\frac{5}{16}$	0.9	2
10.0	-	2.3	5
11.0	$\frac{7}{16}$	2.3	5
12.5	$\frac{1}{2}$	2.3	5
14.0	$\frac{9}{16}$	2.3	5
16.0	$\frac{5}{8}$	4.5	10
20.0	$1\frac{3}{16}$	4.5	10
22.0	$\frac{7}{8}$	4.5	10
25.0	1	4.5	10

Notes: \*Please consult James Walker.



# Lionpak®

## 9602

Mineral fibre for high temperature static and dynamic sealing duties

**Lionpak® 9602 comprises an interlocked braid of fibrous form, inorganic refractory oxides - silica fibre with no metallic or ceramic content.**

It is impregnated with anti-frictional graphite flake and James Walker's proprietary, high temperature, graphite-based dispersion. It also incorporates a metal corrosion inhibitor.

#### Prime features

- Suitable for many high temperature duties.
- Resistant to wear and abrasion.
- Corrosion inhibitor safeguards metallic interfaces from galvanic corrosion.
- Resistant to high temperatures.

#### Typical applications

Recommended for hydro-testing of heat exchangers; also for general duties with furnace and oven doors. Suitable for duties with superheated steam and saturated steam, water, dyes, chemicals, non-oxidising liquids and gases. This product is also suitable for use on valves and centrifugal pumps.

#### Chemical properties

Compatible with media in the range pH 0-14.

#### Health & Safety considerations

Average diameter of the mineral fibre used in is over 6µm (236µin), which is considered non-hazardous to health. No protection for breathing, eye, hand or body is required by the World Health Organisation or European Union for the material's normal handling, storage or use.

For further details please request a copy of our Safety Data Sheet (SDS).

Note that normal ceramic fibres, as often used in the manufacture of very high temperature compression packings, are around 3µm (118µin) in diameter. These much finer fibres are considered hazardous to health, with WHO and EU restrictions applied to the products that contain them.

#### How supplied

All popular square sections from 3 mm to 50 mm (1/8" to 2") in boxes containing 8 m (26' 3"), in coil form or on spools as detailed in the table below. Also supplied as split preformed rings and sets.

Spool ordering information			
Size		Packaged ± 10%	
mm	inch	kg	lbs
3.0	1/8	0.9	2
5.0	3/16	0.9	2
6.5	1/4	0.9	2
8.0	5/16	0.9	2
10.0	-	2.3	5
11.0	7/16	2.3	5
12.5	1/2	2.3	5
14.0	9/16	2.3	5
16.0	5/8	4.5	10
20.0	13/16	4.5	10
22.0	7/8	4.5	10
25.0	1	4.5	10

#### Notes:

\*Please consult James Walker.

# Lionpak®

## 9605

Packing for high temperature static duties

**Lionpak® 9605 is a high temperature, wear-resistant and densely braided packing.**

It is manufactured from a core of braided glass yarns, coated with graphite and protected by a tough sleeve of braided copper wire.

#### Prime features

- Tough and flexible for arduous duties.
- Static sealing duties up to +680°C (+1256°F).

#### Typical applications

Extensively used as a furnace door and kiln packing and for exhaust expansion glands. It can also be used for very slow rotating duties when liberally coated with copper anti-seize compound.

#### Chemical properties

Resists super-heated steam, hot air and hot gases in the range pH 4-10.

#### How supplied

All popular round or square cross-sections from 3 mm to 50 mm (1/8" to 2"), in boxes containing 8 m (26' 3"), in coil form or on spools as detailed in the table below. Also supplied as split preformed rings and sets.

Spool ordering information			
Size		Packaged ± 10%	
mm	inch	kg	lbs
3.0	1/8	0.9	2
5.0	3/16	0.9	2
6.5	1/4	0.9	2
8.0	5/16	0.9	2
10.0	-	2.3	5
11.0	7/16	2.3	5
12.5	1/2	2.3	5
14.0	9/16	2.3	5
16.0	5/8	4.5	10
20.0	13/16	4.5	10
22.0	7/8	4.5	10
25.0	1	4.5	10

Notes: \*Please consult James Walker.

#### SPECIALISED PACKING



#### VALVE STEM DUTIES

Maximum Operating Temperature:

+550°C (+1022°F)

Minimum Temperature:

-50°C (-58°F)

Maximum System Pressure:

8 MPa/80 bar (1160 psi)



#### CENTRIFUGAL PUMPS AND ROTARY EQUIPMENT

Maximum Operating Temperature:

+550°C (+1022°F)

Minimum Operating Temperature:

-50°C (-58°F)

Maximum Shaft Speed:

10 m/s (1969 fpm)

Maximum System Pressure:

2 MPa/20 bar (290 psi)



#### STATIC DUTIES

Maximum Operating Temperature:

+550°C (+1022°F)

Minimum Operating Temperature:

-50°C (-58°F)

Maximum Static Pressure:

Dependent on application\*

#### SPECIALISED PACKING



#### STATIC DUTIES – FURNACE DOORS

Maximum Operating Temperature:

+680°C (+1256°F)

Minimum Operating Temperature:

-10°C (+14°F)

Maximum System Pressures:

Static

0.5 MPa/5 bar (73 psi)

Rotary

Dependent on application\*

# Let's talk Expert2Expert

**“We recognise that our customers are experts in their field, just as our specialists are in theirs. It’s a partnership that delivers the very best value, from our experts to yours.”**

**Dipak Shiroya**  
Technical Manager  
Compression Packing



OVER  
**2000**  
people  
worldwide



**Today we have over 2,000 people worldwide, all focused on solving customers' challenges.**

Their shared knowledge, backed up by over 135 years of James Walker experience in the development and manufacture of compression packings, underpins the performance of every product in our range.

Effective solutions are the result of our experts talking to your experts first to understand the root cause of issues and challenges; then we apply our expertise to develop a solution.

Whether in relation to the materials, lubricants and additives that make up the product, or detailed instructions on installation best practice, or our research and technical papers on specialist areas such as fugitive emissions control - James Walker experience and expertise is available to our customers at all times, to help optimise operational performance and meet the most challenging application conditions.

**We are experts in compression packing.**

**Behind the brand**

Our expertise is founded on our heritage, knowledge and our breadth of offer, which is continually evolving.

over **135** years of  
experience

# Let's talk Expert2Expert

## Housing Design

As with all sealing arrangements attention to detail is required to achieve acceptable fugitive emission performance from a packed valve gland.

The following is the recommended arrangement for packing and stuffing box design for use with James Walker compression packing.

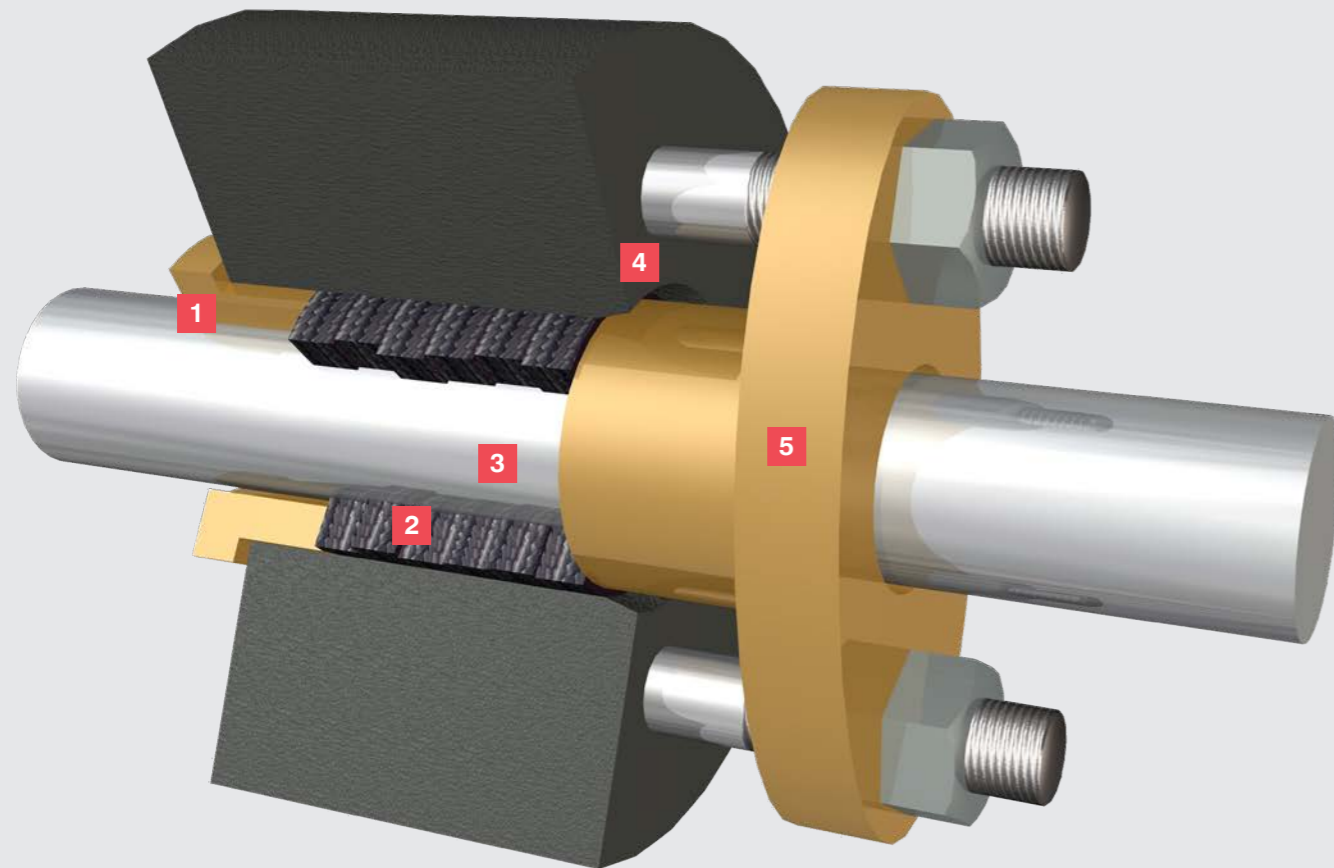

### 1 Pressure side extrusion clearance 0.25 mm (0.01") maximum

The extrusion clearance on the atmospheric side of the packing is usually well controlled, that on the pressure side is sometimes neglected. If too large, externally applied compression can cause packing material to extrude into this clearance - this can damage the packing and lead to a substantial increase in valve friction.

### 2 Number of packing rings

It is recommended that between four and six packing rings are used.

This number will vary depending on:

- The depth of the stuffing box.
- Length of gland follower spigot.
- The use of a lantern ring or bleed-off port.

### 3 Surface finish

The surface finish and method of producing this finish is neglected as unimportant by many seal suppliers. Through extensive test work and experimentation within the James Walker Technology Centre, we can state with confidence that a stem surface finish of 0.4 to 0.6µmRa (16 to 24µ inch CLA) provides optimised performance of stem friction and low leakage levels with graphite based compression packing.

This detail is essential if specifications such as ISO 15848 and TA luft/VDI2440 are to be achieved.

### Production of the surface finish

Using either a plunge grinding or transverse grinding method of generating this surface finish rather than 'turning' can prevent the tracking of gaseous media past the seal to atmosphere.

### Surface hardness

The longevity of a valve stem can be improved by increasing the surface hardness. For 'normal' applications a hardness of between 40 and 60 Rockwell C is suggested.

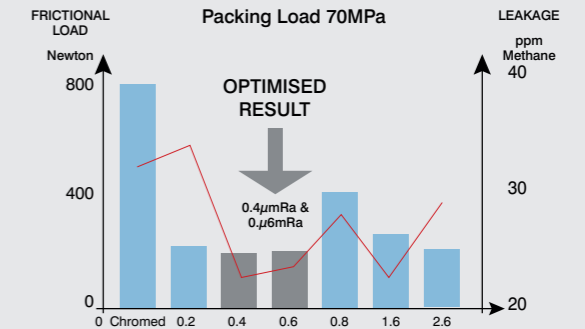

### 4 Housing lead-in - 15deg x (Housing Section in mm/2)

Many valves lack the provision of lead-in chamfer to the gland and surface damage to the packing can often result during assembly.

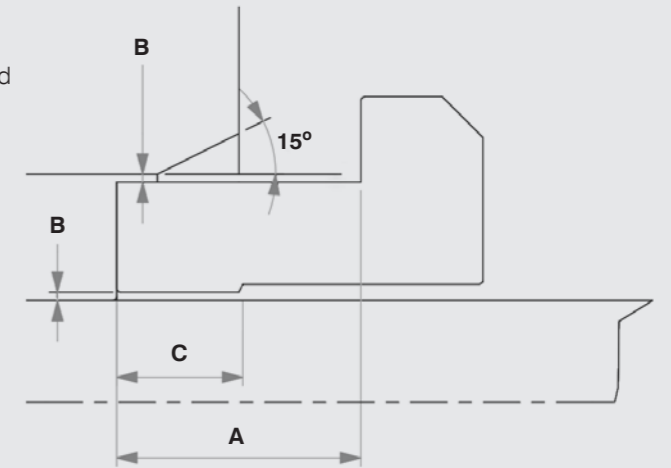

### 5 Gland follower design (spigot entry)

A - (no. packing rings) x (nominal packing ring section x 0.5)

B - Typically 0.2 mm. larger extrusion gaps are acceptable, but may impact performance/max. pressure capability.

C - Nominal packing section

### Housing (packing) section

Below is a recommendation for housing width dependent on shaft diameter.

Please note these are for guidance only and selections outside of this may have no detrimental effect on valve performance.

Braided packing		Graphite moulded rings	
Shaft diameter mm (inches)	Housing width mm (inches)	Shaft diameter mm (inches)	Housing width mm (inches)
<12 (<½)	3 (⅛)	<18 (¾)	3 (⅛)
12 to 18 (½ to ⅞)	5 (⅜)	18 to 75 (¾ to 3)	5 (⅜)
18 to 25 (⅞ to 1)	6.5 (¼)	75 to 150 (3 to 6)	8 (⅜)
25 to 50 (1 to 2)	8 (⅝)	>150 (>6)	10 (⅜)
50 to 90 (2 to 3½)	10 (⅜)		
90 to 150 (3½ to 6)	12.5 (½)		

Emission  
levels as  
low as

# 5 ppmV



## Supagraf® Range

The complete performance package for critical applications.

**Supagraf® is our graphite-based range of compression packings designed to meet the critical, high performance sealing demands of oxygen service and fugitive emissions control applications.**

These products have undergone industry standards testing and customer-specific approvals testing, to provide the highest levels of performance assurance to end-users and OEM customers alike.

Supagraf® delivers proven performance to the most exacting standards.

- API 622
- ISO 15848-1 Class AH CO3
- ISO 15848-1 Class BH CC3
- TA Luft Rev07.2002
- Shell Spec SPE 77/312 Class A
- Shell Spec SPE 77/312 Class B
- API 607 Edition 4 fire safety
- Shell MESC SPE 85/204

### Page reference guide

<b>Supagraf®</b> Premier	62	<b>Supagraf®</b> Control	65
<b>Supagraf®</b> FE	63	<b>Supagraf®</b> HT	66
<b>Supagraf®</b> Premipak	64	<b>Supagraf®</b> OX	67

### Behind the brand

Independent emission control tests show that gas leakage past a set of Supagraf® Premier valve packings, one of our world-leading packings, is less than the volume of a golf ball in a year!





# Supagraf®

## Premier

World-beating fugitive emissions control packing



### VALVE STEM DUTIES

Maximum Operating Temperature:  
Oxidising conditions

+450°C (+842°F)

Minimum Operating Temperature:

-200°C (-328°F)

Maximum System Pressure (standard)\*:

25 MPa/250 bar (3626 psi)

Certified Pressure in BSM Valve:

69 MPa/690 bar (10,000 psi)

### Supagraf® Premier is one of James Walker's top-of-the-range fugitive emission control packing for valves.

Third party tested to all known industry standards producing exceptional performance - 10.5 ppmV average emission level in API 622 2nd edition test with no adjustments.

It is manufactured in exfoliated high purity 98% graphite, reinforced in a novel way to provide additional strength and resistance to pressure and extrusion. It incorporates an advanced lubricant system that prevents the pick-up of graphite on valve stems.

#### Prime features

- Third party verified emission control performance.
- Suitable for both rotary as well as rising-stem valve application.
- Low friction performance without graphite pick-up reducing the torque needed for efficient valve action.
- Fire safe capability confirmed by third-party certification according to API 607 Edition 4 Fire Safety.

#### Typical applications

Designed for harsh operating conditions where fugitive emissions from all types of valves need to be reduced to well below 50 ppm. It is well proven and widely used in systems handling fluid media such as hydrocarbon liquid fuels and gases, lubricating oils and processing chemicals.

#### Specifications

Supagraf Premier is third-party tested and certified to:

- ISO 15848-1 Class AH (fugitive emissions): Certified by ITIS BV at 69 MPa (static) with a five-ring set in a BSM valve. Emission level at 69 MPa/690 bar (10,000 psi) was ≤5 ppmV.
- API 622 2nd Edition. Average emission level of 10.5 ppmV over five thermal cycles and 1510 mechanical cycles with no adjustment made.
- TA Luft / VDI 2440 Rev. 07.2002.

- Shell specification SPE 77/312 Class AH, Rev. 10.2002.
- Shell specification SPE 77/312 Rev 06.2007: Class B rating with 47.4 MPa/474 bar (6875 psi) helium in Class 2500 valve. Seating stress of 101 MPa (14,649 psi).
- API 607 Edition 4 Fire Safety - to an extended specification.
- Conforms to Shell material specification MESC SPE 85/204.

#### Chemical properties

Compatible with media in the range pH 1-14, excluding strong oxidising agents. It has negligible volatile content.

#### How supplied

All popular square sections from 3 mm (1/8") upwards in boxes containing 8 m (26' 3"), in coil form or on spools as detailed in the table below. Also supplied as split preformed rings and sets. Non-standard square or rectangular sections made to order.

Spool ordering information			
Size		Packaged ± 10%	
mm	inch	kg	lbs
3.0	1/8	0.9	2
5.0	3/16	0.9	2
6.5	1/4	0.9	2
8.0	5/16	0.9	2
10.0	-	2.3	5
11.0	7/16	2.3	5
12.5	1/2	2.3	5
14.0	9/16	2.3	5
16.0	5/8	4.5	10
20.0	13/16	4.5	10
22.0	7/8	4.5	10
25.0	1	4.5	10

Notes: \*Consult James Walker for higher pressures.

# Supagraf®

## FE

New generation fugitive emissions control packing

### Supagraf® FE is a high performance fugitive emission control packing for valves.

Third party tested to all known industry standards producing exceptional performance - 8 ppmV average emission level in API 622 3rd edition test with no adjustments. This is a cost effective fully braided packing manufactured in exfoliated high purity 98% graphite, reinforced with Inconel® wire to provide additional strength and resistance to pressure and extrusion.

This packing incorporates a new generation cutting-edge lubrication system that not only helps to prevent the pick-up of graphite on valve stems but also provides ultra-low friction performance with advanced corrosion inhibiting properties.

#### Prime features

- Third party verified emission control performance.
- Suitable for both rotary as well as rising-stem valve application.
- Ultra-low friction performance without graphite pick-up reducing the torque needed for efficient valve action.
- Fire safe capability confirmed by third-party certification according to API 607 Edition 7 Fire Safety / ISO 10497:2010.
- Suitable for use in valves from pressure Class 150 up to Class 1500 - please consult James Walker for Class 2500 suitability.
- Can mitigate the effects of stem judder and friction by helping to prevent graphite pickup or high spot friction on the valve stem, especially in applications with high rates of thermal cycling and dynamic stem movements.

#### Typical applications

Supagraf FE is designed for harsh operating conditions where fugitive emissions from valves need to be reduced to well below 50 ppm. Suitable for all types of valves performing arduous duties handling fluid media such as hydrocarbon liquid fuels and gases, lubricating oils and processing chemicals. Also suitable for valves that handle dry gases and other fluids.

#### Specifications

Supagraf FE is third-party tested and certified to:

- ISO 15848-1:2015 Class BH (CO<sub>1</sub>) achieved on DN100 gate valve Class 300 with rising stem at test temperature from ambient up to 200°C.
- API 622 3rd Edition. Average emission level of 8 ppmV over five thermal cycles and 1510 mechanical cycles and with no adjustment made.
- TA Luft / VDI 2440 Rev. 07.2002.
- Shell specification SPE 77/312 Class AH Rev. 02.2019.
- API 607 Edition 7 Fire Safety / ISO 10497:2010.
- Conforms to Shell material specification MESC SPE 85/204.

#### Chemical properties

Compatible with media in the range pH 1-14, excluding strong oxidising agents. It has negligible volatile content.

#### How supplied

All popular square sections from 3 mm (1/8") upwards in boxes containing 8 m (26' 3"), in coil form or on spools as detailed in the table below. Also supplied as split preformed rings and sets. Non-standard square or rectangular sections made to order.

Spool ordering information			
Size		Packaged ± 10%	
mm	inch	kg	lbs
3.0	1/8	0.9	2
5.0	3/16	0.9	2
6.5	1/4	0.9	2
8.0	5/16	0.9	2
10.0	-	2.3	5
11.0	7/16	2.3	5
12.5	1/2	2.3	5
14.0	9/16	2.3	5
16.0	5/8	4.5	10
20.0	13/16	4.5	10
22.0	7/8	4.5	10
25.0	1	4.5	10

Notes:

\*Consult James Walker for higher pressures.



### VALVE STEM DUTIES

Maximum Operating Temperature:  
Oxidising conditions

+450°C (+842°F)

Minimum Operating Temperature:

-200°C (-328°F)

Maximum System Pressure (standard)\*:

25 MPa/250 bar (3626 psi)

### APPROVALS



ISO 15848-1 Class AH  
API 622 2nd Edition  
TA Luft / VDI 2440 Rev. 07.2002  
Shell MESC SPE 85/204  
Shell specification  
SPE 77/312 Class A  
Shell specification  
SPE 77/312 Class B  
API 607 Edition 4 Fire Safety

### APPROVALS



ISO 15848-1:2015 Class BH (CO<sub>1</sub>)  
API 622 3rd Edition  
TA Luft VDI 2440 Rev. 07.2002  
Shell MESC SPE 85/204  
Shell specification  
SPE 77/312 Class AH Rev. 02.2019  
API 607 Edition 7 Fire Safety



# Supagraf®

## Premipak

Class-leading combination packing set



### VALVE STEM DUTIES

Maximum Operating Temperature:  
+450°C (+842°F)

Minimum Operating Temperature:  
-200°C (-328°F)

Maximum System Pressure:  
25 MPa/250 bar (3626 psi)

**Supagraf® Premipak is a superior combination packing set for valves. It is based on two class-leading graphite products.**

**End rings:** Supagraf® Premier braided high purity 98% graphite filament packing for high strength and extrusion resistance with excellent sealability, plus third-party certification to TA Luft emission control requirements.

These rings conform to Shell material specification MESC SPE 85/204.

**Intermediate rings:** Special moulded rings of high purity graphite foil, that offer low friction and excellent heat transfer characteristics, plus high efficiency sealing.

These rings conform to Shell material specification MESC SPE 85/203.

#### Prime features

- Reduced valve stem shudder and hesitation.
- Low break-out friction.
- Long working life with minimal maintenance.

#### Typical applications

Stop valves and control valves performing arduous duties with media such as hydrocarbon liquid fuels and gases. Most applications require VOC fugitive emission control to 100 ppm or better, with a maximum working temperature of up to +450°C (+842°F).

#### Chemical properties

Compatible with media in the range pH 1-14, excluding strong oxidising agents.

#### How supplied

As precision moulded rings in endless form, or with single split, to meet customers' requirements. Sections: 3 mm to 40 mm ( $\frac{1}{8}$ " to  $1\frac{3}{16}$ "). Diameters: 5 mm to 500 mm ( $\frac{3}{16}$ " to  $19\frac{3}{4}$ " ID).

### APPROVALS

Shell MESC SPE 85/203  
Shell MESC SPE 85/204



# Supagraf®

## Control

Long-term sealing plus fugitive emission control

**Supagraf® Control is an innovative compression packing that provides long-term, high integrity sealing for control valves. Its very low friction enhances the control accuracy of valves.**

This is a 'best available technique' product for reducing industry's VOC fugitive emissions in line with the European Union's IPPC Directive.

It is manufactured in exfoliated graphite, reinforced in a novel way with a non-metallic structure to provide additional strength and resistance to pressure and extrusion.

An advanced lubricant system is incorporated to prevent the pick-up of graphite on valve stems.

#### Prime features

- High integrity gland sealing for control valve stems: to well below 50 ppm fugitive emission level.
- Long-term adjustment-free operation: over 100,000 stem strokes with emission levels below 50 ppmV .
- Very low coefficient of friction for smooth and accurate valve action.
- Reduced friction requirement to save on power consumption and enable smaller actuators to be used.

#### Typical applications

Supagraf® Control is designed for emission control - to better than 50 ppmV leak tightness - on control valves in systems handling fluid media such as hydrocarbon liquid fuels and gases, lubricating oils and hazardous process chemicals.

It is a long-term replacement for the PTFE V-type packings that can be readily damaged by ingress of dirt and other foreign particles to the gland area.

#### Specifications

- TA Luft/VDI 2440: Dresser Masoneilan control valves fitted with Supagraf® Control are certified to TA Luft requirements at leak tightness with helium to  $<10^{-4}$  mbar.litre.s<sup>-1</sup>.m<sup>-1</sup>. The tests

were undertaken with 10 MPa/100 bar (1450 psi) at 20°C (68°F), and 5.7 MPa/57 bar (827 psi) at a fluid flow temperature of 425°C (797°F) for 100,000 stem cycles.

- ISO 15848-1: Dresser Masoneilan control valves fitted with Supagraf® Control are certified to ISO 15848-1 Class BH, CC3, at temperatures from -29°C to +425°C (-20°F to +797°F). The valves showed helium leakage rates  $<10^{-4}$  mg.s<sup>-1</sup>.m<sup>-1</sup> for 100,000 stem operating cycles. This was achieved with pressure of 5.75 MPa/57 bar (834 psi) at fluid flow temperature of +425°C (+797°F) and 10.34 MPa/103 bar (1500 psi) at -29°C to +38°C (-20°F to +100°F).

#### Chemical properties

Compatible with media in the range pH 1-14, excluding strong oxidising agents. It has low volatiles content.

#### How supplied

All popular square sections from 3 mm ( $\frac{1}{8}$ " ) upwards in boxes containing 8 m (26' 3"), in coil form or on spools as detailed in the table below. Also supplied as split preformed rings and sets.

Spool ordering information			
Size		Packaged $\pm 10\%$	
mm	inch	kg	lbs
3.0	$\frac{1}{8}$	0.9	2
5.0	$\frac{3}{16}$	0.9	2
6.5	$\frac{1}{4}$	0.9	2
8.0	$\frac{5}{16}$	2.3	5
10.0	-	2.3	5
11.0	$\frac{7}{16}$	2.3	5
12.5	$\frac{1}{2}$	4.5	10
14.0	$\frac{9}{16}$	4.5	10
16.0	$\frac{5}{8}$	4.5	10
20.0	$1\frac{3}{16}$	4.5	10
22.0	$\frac{7}{8}$	4.5	10
25.0	1	4.5	10



### VALVE STEM DUTIES

Maximum Operating Temperature:  
With Thermal Cycling  
+350°C (+662°F)

Minimum Operating Temperature:  
-200°C (-328°F)

Maximum System Pressure:  
25 MPa/250 bar (3626 psi)

### APPROVALS



TA Luft/VDI 2440  
ISO 15848-1 Class BH, CC3



# Supagraf®

## HT

66

Ultra-high temperature resistant packing

**Supagraf® HT is one of James Walker's high performance packings suitable for critical valves handling various high temperature media such as molten salt used in solar thermal power plants.**

Premium grade unique and bespoke combination set construction comprising of high temperature mechanically stable intermediate and end ring DS Pro spacers supported by high purity graphite-based intermediate packing rings.

**Graphite rings:** High performance packing braided from high purity 98% exfoliated dry graphite yarn with passive corrosion inhibitor, reinforced with fine Inconel® wire and free from all other additives or dispersions in order to maximise temperature and corrosion resistance capabilities.

Graphite base material conforms to Shell material specification MESC SPE 85/204.

**DS Pro spacers:** Precision cut spacers made of state-of-the-art material designed for electro-mechanical and thermo-mechanical applications with excellent resistance to heat and open flame up to 1000°C (1832°F). Excellent electrical insulation and high resistance to pressure as well as impervious to most chemicals such as molten salt. The product has improved dimensional stability at high temperatures, low water absorption and is asbestos free, ecologically safe and non-toxic. Typically of 2-3 mm thickness and in multiple layers, customised to valve stuffing box geometry and design.

### Prime features

- Exceptional high temperature resistance.
- Excellent chemical resistance.
- Corrosion resistance capabilities.
- Inconel wire reinforcement enhances thermal expansion capabilities in high temperature cycles.
- Low oxidation rate and long service life in high temperature applications.
- Easy to install, remove and replace.
- 3rd party tested in high temperature molten salt valve applications.
- Suitable for both rotary as well as rising-stem valve applications from pressure Class 150 up to Class 600. Please consult James Walker for higher Class range suitability.

### Typical applications

Supagraf® HT is designed for chemically aggressive and abrasive operating conditions in all types of valves, where resistance to high temperature media such as molten salt as well as extended dynamic sealing performance is required.

### Chemical properties

Compatible with media in the range of pH 0-14 excluding strong oxidising agents. The product has negligible volatile content.

### How supplied

As preformed graphite rings with a single split combined with precision cut DS Pro spacers supplied endless or split in two matched halves. Product made to order to suit application requirements.

### Notes:

Inconel® is a registered trademark of Special Metals Corporation.

# Supagraf®

## OX

67

Graphite yarn compression packing for valves in oxygen service



**Supagraf® OX has been developed specifically for valve services with gaseous and liquid oxygen, to provide safe operation and low emission rates.**

This valve stem packing is manufactured in a clean room environment, from yarn to finished product. It comprises high purity flexible graphite yarn treated with oxidation inhibitors. The yarns are individually reinforced with Inconel® 600 wire mesh.

### Specifications

- Oxygen service capabilities as stated in BAM report 16028840 E.
- Conforms to Shell material specification MESC SPE 85/204.
- Listed by name in the Shell material specification MESC SPE 77/303.

Please contact James Walker for copies of test reports.

### Typical applications

Valves handling gaseous or liquid oxygen. For applications involving media other than oxygen, please consult James Walker.

It is NOT suitable for use with control valves where fine adjustment is required, as this is a dry product that does not contain a lubricant package.

### Chemical properties

Compatible with media in the range pH 1-14, excluding strong oxidising agents. It has negligible volatile content.

### How supplied

All popular square sections from 3 mm to 25 mm (1/8" to 1") in boxes containing 8 m (26' 3"), or in coil form by the metre/foot or kilogram/pound. Also supplied as split preformed rings and sets.

### Notes:

Inconel® is a registered trademark of Special Metals Corporation.



### VALVE STEM DUTIES

#### Gaseous oxygen service

Up to +60°C (+140°F)

#### Maximum oxygen pressure

44 MPa/440 bar (6382 psi)

#### Gaseous oxygen service

+60°C (+140°F)

up to +300°C (+572°F)

#### Maximum oxygen pressure

25 MPa/250 bar (3626 psi)

#### Liquid oxygen service

#### Limit system pressure to:

45 MPa/450 bar (6527 psi)

### APPROVALS



BAM certified

Shell MESC SPE 85/204

Shell MESC SPE 77/303



### VALVE STEM DUTIES

#### Maximum Operating Temperature:

Up to +650°C (+1202°F)

#### Minimum Operating Temperature:

-200°C (+328°F)

#### Maximum System Pressure (Standard):

10 MPa/100 bar (1450 psi) \*

\* Please consult with James Walker where higher system pressures are required.



sealing  
for all

**IMO**  
classes

# Tankatite® & TorrLid® Ranges

The complete package for tank, crucible and furnace door sealing applications.

## Tankatite®

**Our comprehensive Tankatite® range of tank lid packings.**

Developed to meet the increasingly stringent international regulations that cover the maritime transport of chemical and potentially hazardous cargoes.

Extensions to the range cover the requirements of road and rail transport, plus static or mobile tank containers.

## TorrLid®

**TorrLid® is a specialised high-temperature product.**

Designed for high temperature static duties such as crucible lids in metal smelting applications and the sealing of furnace doors.

### Page reference guide

<b>Tankatite®</b> 250	70
<b>Tankatite®</b> 440	71
<b>Tankatite®</b> 660	72
<b>Tankatite®</b> 880 ACR	73
<b>Tankatite®</b> 880 Super	74
<b>TorrLid®</b> 162B	75
<b>TorrLid®</b> 297	76



# Tankatite®

## 250



Packing for road and rail tankers



### STATIC DUTIES ON TANK LIDS

Maximum Operating Temperature:

+100°C (+212°F)

Minimum Operating Temperature:

-30°C (-22°F)

Maximum Tank Pressure:

50 kPa/0.5 bar (7 psi)

**Tankatite® 250 is a state of the art packing design specifically developed for production in rectangular sections and at smaller sections to suit the smaller tank lid recesses of road and rail tankers.**

#### Prime features

- Easy to cut and fit in small section lid recesses.
- Tough, resilient and long-life product.
- Withstands repeated opening/closing cycles.
- Controls emission levels from tanks.
- Protects tank contents from contamination.
- Withstands arduous cleaning systems.

#### Typical applications

Seals to fit the smaller tank lid recesses of road and rail tankers.

#### Chemical properties

Compatible with media in the range pH 1-13 at normal operating temperatures, excluding fluorine gas.

#### How supplied

As length form packing or endless rings to fit popular lid recess dimensions.

# Tankatite®

## 440



Suitable for all types of vessel and IMO classes



### STATIC DUTIES ON TANK LIDS

Maximum Operating Temperature:

+120°C (+248°F)

Minimum Operating Temperature:

-50°C (-58°F)

Maximum Tank Pressure:

70 kPa/0.7 bar (10 psi)

**Tankatite® 440 is a resilient elastomeric core, spirally wrapped with PTFE tape and surrounded by successive braided jackets of inert polypropylene yarn. Specially reinforced corners are incorporated to build the section to the required packing size.**

The braided structure is spirally wrapped with further layers of PTFE tape to provide an impermeable barrier to liquids and gases, then finally enclosed in a robust, abrasion resistant braid of PTFE yarns.

#### Prime features

- Gas-tight environmental seal.
- Protects cargo from sea water ingress.
- Withstands repeated opening/closing cycles.
- Unaffected by steam and other tank cleaning systems.
- Suitable for smooth recesses in stainless steel lids as well as those with rougher surface finishes.

#### Typical applications

Sealing of tank lids, main hatches, inspection and cleaning covers on tankers carrying all known bulk liquid cargoes in all International Maritime Organisation (IMO) classes.

#### Specifications

- Meets US Coast Guard requirements for lid sealing of hazardous cargoes.
- Pressure tight beyond Lloyd's and DNV test criteria.

#### Chemical properties

Compatible with media in the range pH 0-14, including all known bulk cargoes in all IMO classes.

#### How supplied

Any square or rectangular sections of 12.5 mm (½") upwards is made to order; also endless rings to fit specific tank lid recesses.

# Tankatite®

## 660



Designed for heated cargoes

### A heat resistant grade of Tankatite®

Similar in construction to Tankatite® 440, but with braided jackets of high quality glass fibre yarns instead of polypropylene.

#### Prime features

- Gas-tight environmental seal for heated cargoes.
- Protects cargo from sea water ingress.
- Withstands repeated opening/closing cycles.
- Unaffected by steam and other tank cleaning systems.

#### Typical applications

Seals for tank lids that cover heated cargoes, such as molten bitumen, which need to be transported at elevated temperatures to prevent solidification in the tank.

#### Chemical properties

Compatible with media in the range pH 0-14, including all known bulk liquid cargoes in all IMO classes.

#### How supplied

Any square or rectangular sections of 12.5 mm (½") upwards is made to order; also endless rings to fit specific tank lid recesses.



#### STATIC DUTIES ON TANK LIDS

Maximum Operating Temperature:  
+230°C (+446°F)

Minimum Operating Temperature:  
-50°C (-58°F)

Maximum Tank Pressure:  
60 kPa/0.6 bar (9 psi)

# Tankatite®

## 880 ACR



For static and mobile tank containers

### Tankatite® 880 ACR is a new economical grade of general purpose lid packing for tank containers, road and rail tankers, especially where the packing needs to be changed after each trip/cargo.

It is a white packing constructed from spun acrylic fibre yarns impregnated with PTFE suspension. Dense but flexible, it is easy to cut and fit, and to remove when it needs to be replaced.

#### Prime features

- Excellent value for money.
- Contains no grease or oil - no lubricant to squeeze out when packing is compressed.
- Easy to cut and fit in small section lid recesses.
- Easy to remove when it needs replacing.
- Protects tank contents from external contamination.
- Approved, specified and used by major tank container operators world wide.

#### Typical applications

Seals for lids and fittings on tank containers for road, rail or static use that contain chemicals, petroleum products or foodstuffs.

This general purpose lid packing for tank containers, road and rail tankers, proves invaluable when the packing needs to be changed after each trip/cargo.

#### Chemical properties

Compatible with media in the range pH 2-12.

Compatible with a full range of cargoes, including chemicals, petroleum products and foodstuffs.

#### How supplied

Available in popular sections from 10 mm (¾") up to 20 mm (¾") in coils of 50 m (164') and cut lengths to suit individual lids.



#### STATIC DUTIES ON TANK LIDS

Maximum Operating Temperature:  
+250°C(+482°F)

Minimum Operating Temperature:  
-50°C (-58°F)

Maximum Tank Pressure:  
200 kPa/2 bar (29 psi)

# Tankatite®

## 880 Super



For static and mobile tank containers

**Tankatite® 880 Super is a clean, length-form packing manufactured from an inert reinforced polypropylene yarn, impregnated with PTFE and an inert resin to provide a non-stick surface.**

It contains a resilient elastomeric core for improved performance.

#### Prime features

- Excellent value for money.
- Equivalent performance to moulded rubber seals.
- Easy to cut and fit in small section lid recesses.
- Excellent sealing capability on repeated opening/closing cycles.
- Controls emission levels from tanks.
- Protects tank contents from external contamination.
- Withstands arduous cleaning systems.

#### Typical applications

Seals for lids and fittings on tank containers for road, rail or static use, that contain chemicals, petroleum products or foodstuffs. Also for lids and fittings on dedicated tanks that handle aggressive cargoes under an inert gas blanket. It readily replaces moulded rubber sealing components and low cost packings.

#### Chemical properties

Compatible with media in the range pH 0-14. Totally compatible with a full range of cargoes, including chemicals, petroleum products and foodstuffs.

#### How supplied

As coil-form packing and endless rings, in sections to fit popular lid recess dimensions.

# TorrLid®

## 162B



Vacuum seal for aluminium crucible lids

**This specialised product has been developed specifically as a lid seal to hold a vacuum within crucibles of molten aluminium.**

It features a resilient hollow-centred core of ethylene-propylene elastomer, over-braided with a jacket of filament glass yarns. The exterior surface is coated with a layer of red-coloured silicone rubber.

#### Prime features

- Developed specifically as a vacuum seal for aluminium crucible lids.
- Readily withstands the temperatures and compressive forces involved.
- Tough silicone rubber coating provides abrasion resistance.
- Withstands repeated opening/closing cycles.

#### Typical applications

This exceptionally well-proven product is used worldwide as a vacuum lid seal for crucibles containing molten aluminium. It has also proved a great success on new plant using the latest AP35 technology.

#### How supplied

Manufactured to order, in a wide variety of sections and lengths, to meet customers' specific requirements.

#### Notes: \*Please consult James Walker

Product also available in wire reinforced version - TorrLid 162C.



#### STATIC DUTIES WITH CRUCIBLE LIDS

**Maximum Working Temperature:**  
Suitable for holding a vacuum over molten aluminium in crucibles.\*

**Pressure Range:**  
From partial vacuum up to 0.9 MPa/9 bar (131 psi)



#### STATIC DUTIES ON TANK LIDS

**Maximum Operating Temperature:**  
+120°C(+248°F)

**Minimum Operating Temperature:**  
-50°C (-58°F)

**Maximum Tank Pressure:**  
200 kPa/2 bar (29 psi)

# TorrLid®

## 297



Crucible lid seal for higher temperatures



### STATIC DUTIES WITH CRUCIBLE LIDS

#### Maximum Working Temperature:

Suitable for holding a vacuum over molten aluminium in crucibles.\*

#### Pressure Range:

From partial vacuum up to 0.9 MPa/9 bar (131 psi)

**This highly specialised product features a resilient, hollow-centred elastomeric core that resists higher temperatures than the ethylene-propylene used in TorrLid® 162B.**

The core is over-braided with a jacket of filament glass yarns, and the exterior surface is then coated with a proprietary graphite dispersion.

#### Prime features

- Developed as a higher temperature vacuum seal for the lids of crucibles as used in specific aluminium smelting plants.
- Readily withstands the temperatures and compressive forces involved.
- Withstands repeated opening/closing cycles.

#### Typical applications

This well-proven product is used as a vacuum lid seal for crucibles containing molten aluminium. It is particularly popular with aluminium plants in the southern hemisphere.

#### How supplied

Manufactured to order, in a wide variety of sections and lengths, to meet customers' specific requirements.

Notes: \*Please consult James Walker.

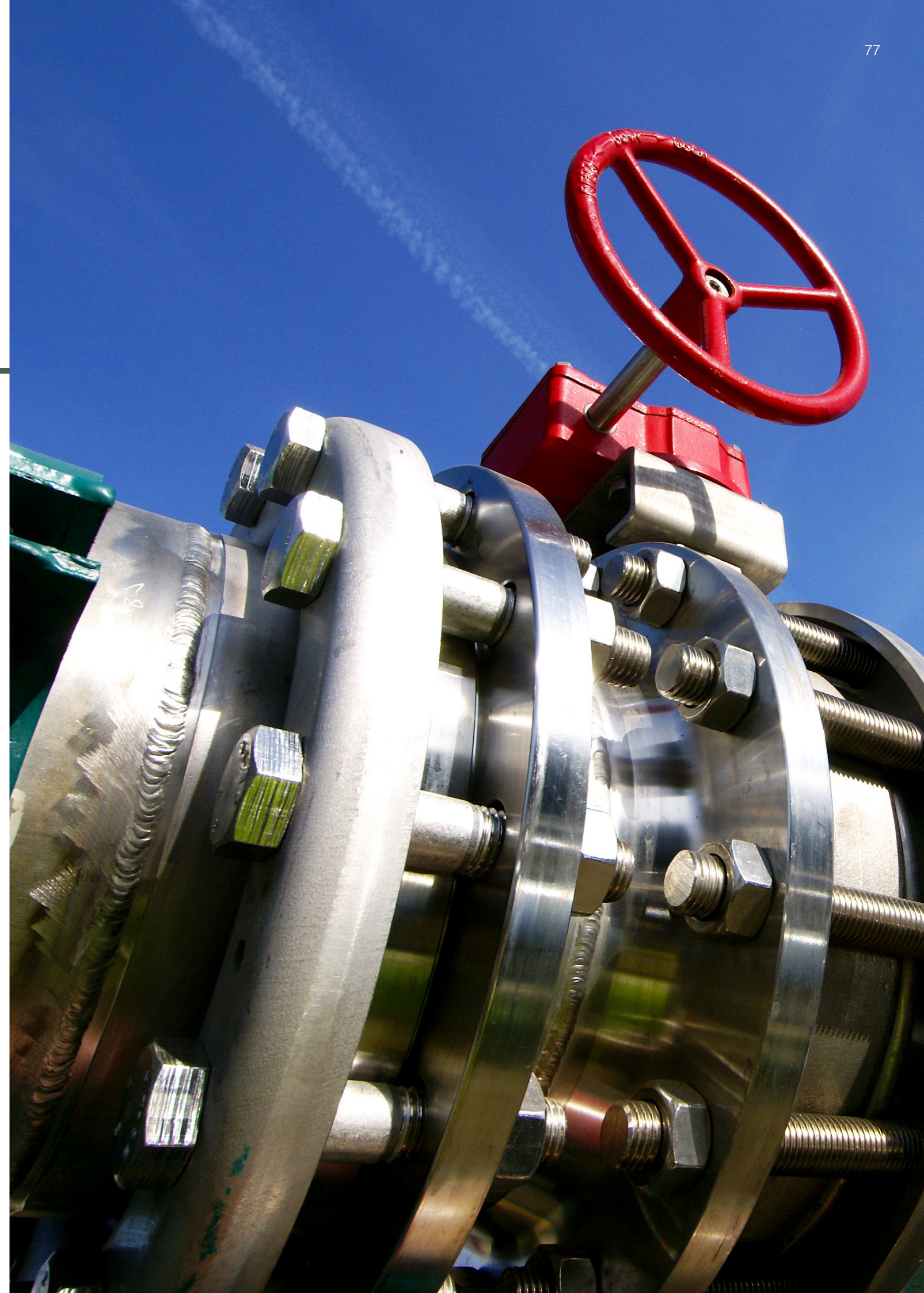

# Let's talk about value

**“Our success is driven by an ambition to provide complete performance... we bring our expertise to today's challenges and our thinking to new applications and markets.”**

**Jakub Marczyk**  
Product Manager  
Compression Packing



We understand that performance means more than just output.

That's why we pride ourselves on being a reliable and trusted partner to original equipment manufacturers and end users of every size around the globe.

Through our Expert2Expert support and the breadth and availability of our product range, we are able to make wider operational efficiencies a reality for our customers.

Across the complete range of James Walker compression packing products we endeavour to provide the choice of premium, standard and value options. This enables every customer to balance maintenance budgets with the demands of operational performance in any application.

#### **Behind the brand**

Our breadth of experience in developing and manufacturing compression packing provides a unique approach to innovation with advances in manufacturing, materials and performance driving improved value for our customers.

# Let's talk about manufacturing excellence

**James Walker compression packings are manufactured under strict ISO 9001 certified regimes in our new purpose-built factory.**

Stocks of our most popular lines are held for immediate order fulfilment.

Technical support is always available from local James Walker companies; particularly challenging applications may also call upon regional technical resources, or ultimately refer to our global product manufacturing and development centre of excellence.

Our in-house research and test facilities enable continual product development and improvement. They allow us to address specific challenges for our customers, and find the right solution faster.

**“Our ability to develop and manufacture our own yarns, combined with an in-depth understanding of lubrication and anti-corrosive ingredients, enables us to continually improve and develop our range of world class packing products”**

**Mukesh Sharma**  
General Manager  
International Business



## Behind the brand

We use our expertise to add to our range of special packings, solving customer issues by providing bespoke solutions for demanding applications.

