

# DSL

## Vertical In-line Double Suction Centrifugal Pump DSL

The DSL pumps are high capacity pumps.  
**Up to 7400 m<sup>3</sup>/h, pressure up to 140 mLC at 60 Hz**

The DSL pumps are single-stage, double-suction, vertical, centrifugal pumps. The design of the suction side provides for a perfect flow, and the inlet is placed in line with the outlet. Add to this the advanced double-suction impeller and the result is high efficiency and low NPSH-values.

### Application

Ballast and cooling water pumping are among the many tasks that the DSL pumps solve to perfection.



Double volute pump casings ensure less radial force on the pump shaft – hence no radial support bearing or shaft seal required in the bottom of the pump. This gives a robust construction, designed for trouble-free continuous duty. The pumps are radially split. In spacer design, service including replacement of bearings and mechanical shaft seal, can be carried out without removing motor and piping. Significant advantages to the benefit of the service personnel. Furthermore, it is possible to supply the pump with a separate priming pumps or ejector.

Nominal diameter (DN)	150 to 600
Flow rate - 50 Hz	Up to 6200 m <sup>3</sup> /h (27300 US gpm)
Flow rate - 60 Hz	Up to 7400 m <sup>3</sup> /h (32600 US gpm)
Head	Up to 140 m (460 ft.)
Pressure	Up to 25 bar (360 psi)
Temperature	Up to 140°C (284°F)
Motor	Standard and EX motors
VFD	Bulkhead/Wall-mounted
ATEX approved.	

### Materials

Alternative material combinations such as stainless steel impeller are available. Maximum working temperature is 120°C for the standard model. For higher temperatures, please contact DESMI. Detailed installation and operation instructions are supplied together with the pump.

Material specification	A	D
Pump casing	Cast iron (GG20)	Bronze (RG5)
Impeller	NiAl-bronze (CC333)	NiAl-bronze (CC333)
Wear ring	NiAl-bronze (CC333)	NiAl-bronze (CC333)
Shaft seal cover	Cast iron (GG20)	Bronze (RG5)
Shaft	Stainless (1.4460)	Stainless (1.4460)
Shaft seal	Mechanical	Mechanical



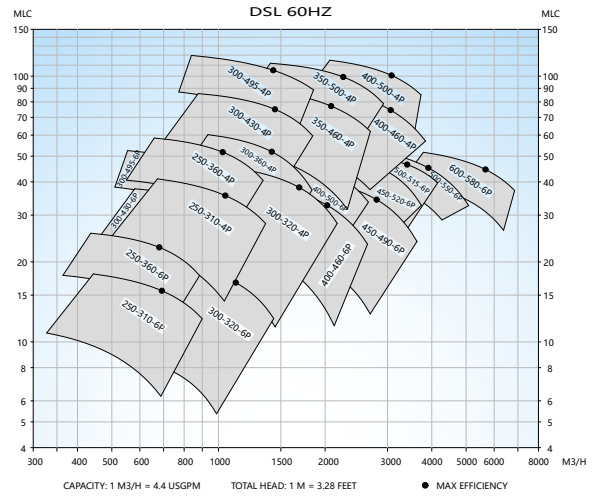
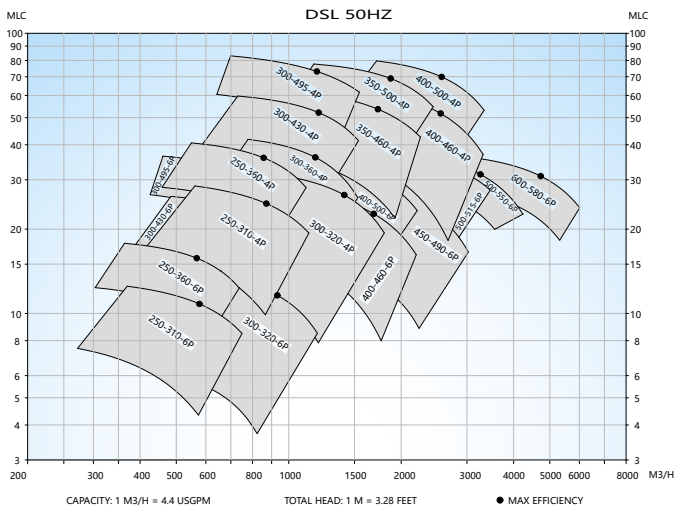

Spacer design

DSL B-U Spacer structure with ball bearing

DSL - B Spacer structure without ball bearing

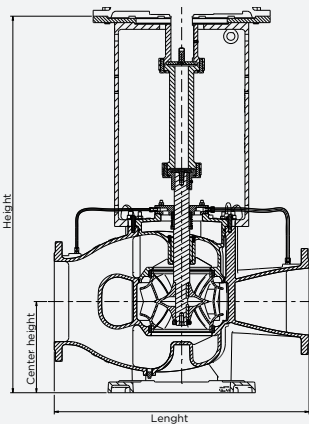
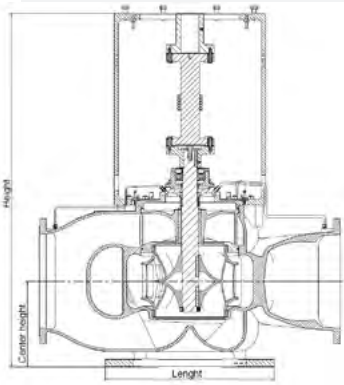

Spacer	Length:	Center Height:	Height:
DSL150-265	680mm	265mm	1165 mm
DSL250-310	950mm	340mm	1380mm
DSL250-360	900mm	340mm	1428mm
DSL300-320	1100mm	400mm	1500mm
DSL300-495	1200mm	425mm	1830mm
DSL350-460	1260mm	400mm	1752mm
DSL400-495	1400mm	500mm	2100mm
DSL500-515	1600mm	455mm	1882mm

Compact design

DSL G-U compact structure with ball bearing

DSL - G compact structure without ball bearing

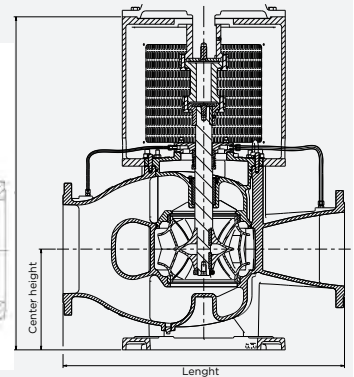
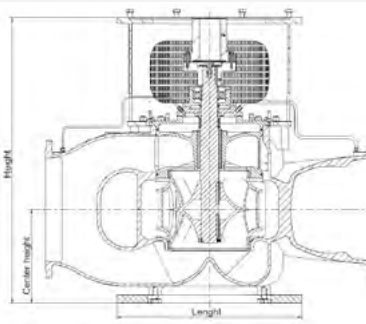

Compact	Length:	Center Height:	Height:
DSL150-265	680mm	265mm	915mm
DSL250-310	950mm	340mm	1124mm
DSL250-360	900mm	340mm	1135mm
DSL300-320	1100mm	400mm	1100mm
DSL300-430	1040mm	375mm	1365mm
DSL300-495	1200mm	375mm	1365mm
DSL350-460	1260mm	400mm	1420mm
DSL400-495	1400mm	500mm	1400mm
DSL400-498	1550mm	440mm	1510mm
DSL450-490	1550mm	470mm	1540mm
DSL500-515	1600mm	455mm	1390mm