

ESL & ESLH

High-Efficiency Vertical In-line and End-suction Single-stage Centrifugal Pumps

DESMI ESL centrifugal pumps are designed for special industrial applications and meet the requirements for:

- Low maintenance costs
- High efficiency
- Low NPSH
- High configuration flexibility
- Installation and serviceability

| | |
|----------------------|---|
| Normal Diameter (DN) | 25 to 100 |
| Flow rate - 50 Hz | Up to 200 m ³ /h (880 US gpm) |
| Flow rate - 60 Hz | Up to 250 m ³ /h (1100 US gpm) |
| Head | Up to 65 m (220 ft) |
| Pressure | Up to 30 bar (435 psi) |
| Temperature | Up to 140°C (284 °F) |
| Motor | Standard and Ex motor |
| VFD | Direct or Bulkead/Wall-mounted |
| ATEX approved | |



Design

ESL pumps are single-stage centrifugal pumps with connecting flanges according to international standards. Further the pumps can be fitted with electric motors with flange dimensions also according to all international standards.

The pumps have been designed in such a way that access to all rotating parts is possible without removing the pump casing from the piping.

All ESL pumps are equipped with mechanical shaft seal of an approved brand.

The impellers are with double curved blades, which ensure high efficiency and low NPSH values.

A Variety of Industrial Applications

- Hot water circulation
- Fresh water circulation
- HVAC
- Hydrophore pump
- Cooling water

The pump can be equipped with an air-driven or electrically driven priming device.



Material specification

| Materials | A | D | S |
|--------------|---------------------------|---------------------------|---------------------------|
| Pump casing | Cast Iron (GG20) | Bronze (RG5) | St. steel (1.4436) |
| Impeller | Bronze (RG10) | Bronze (RG10) | St. steel (1.4436) |
| Sealing ring | Bronze (RG10) | Bronze (RG10) | St. steel (1.4436) |
| Rear cover | Cast iron (GG20) | Bronze (RG10) | St. steel (1.4436) |
| Shaft | Duplex St. steel (1.4460) | Duplex St. steel (1.4460) | Duplex St. steel (1.4460) |
| Shaft seal | Mechanical | Mechanical | Mechanical |

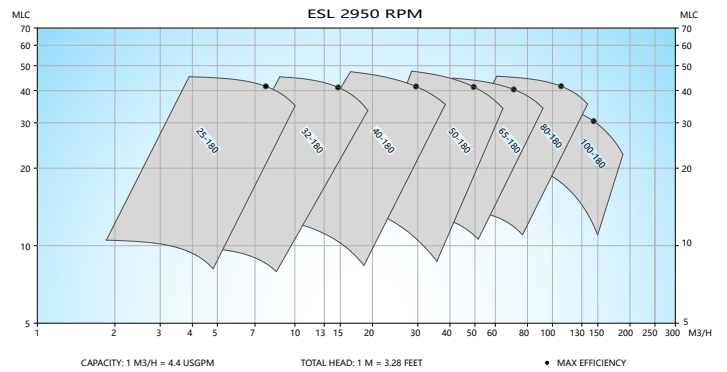

The pumps are also available in other materials such as impeller in ductile iron and various bronze alloys.

Design Details

ESL In-line Pumps with Ø 180 or Ø 190 Impeller

The dimension of the suction flange is identical with the dimension of the discharge flange. The line through inlet and outlet is flush with the centre line of the shaft. The pumps are equipped with one impeller wear ring.

ESLH Pumps with Ø 180 or Ø190 Impeller

The dimension of the suction flange is larger than that of the discharge flange. The line through inlet and outlet is flush with the centre line of the shaft. The pumps are equipped with two impeller wear rings.

Monobloc without Bearings

A sturdy standard pump for clean liquids. Compact design because the rear cover is part of the motor bracket. Dismantling of rotating parts is possible without removing the pump casing from the piping. The ESL in-line pump can be mounted horizontally on request.

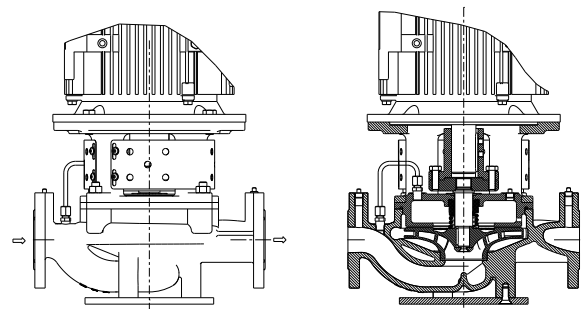

ESL 25-32-40-50

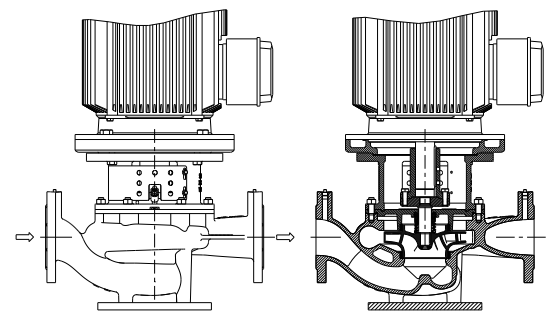

ESL 65-80-100

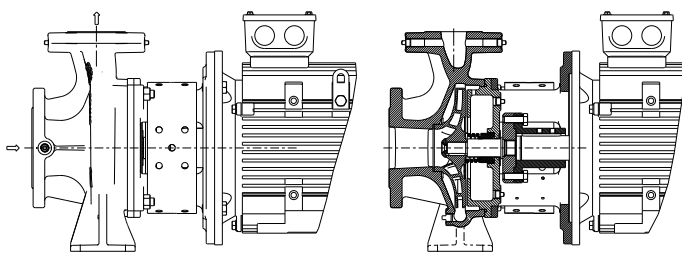

ESLH 25-32-40-50

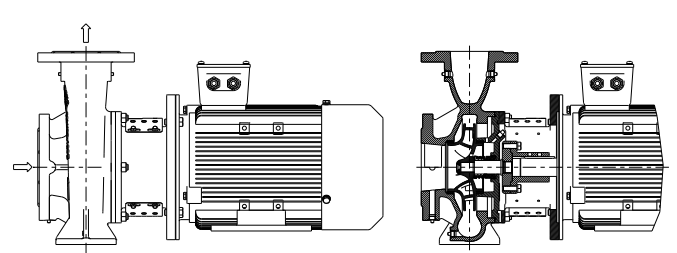

ESLH 65-80-100