

ESL

High-Efficiency In-Line Centrifugal Pumps

Vertically & Horizontally installed

DESMI ESL In-Line Centrifugal Pump is designed for special Utility/District Energy applications in regards to:

- Low maintenance costs
- High efficiency
- Low NPSH
- High configuration flexibility
- Installation and service friendly

Normal Diameter (DN)	25 to 100
Flow rate - 50 Hz	Up to 200 m ³ /h (880 US gpm)
Flow rate - 60 Hz	Up to 250 m ³ /h (1100 US gpm)
Head	Up to 65 m (220 ft)
Pressure	Up to 30 bar (435 psi)
Temperature	Up to 140°C (284 °F)
Motor	Standard and Ex motor
VFD	Direct or Bulkead/Wall-mounted



Design Features

ESL pumps are single-stage centrifugal pumps with connecting flanges according to international standards. Further the pumps can be fitted with electric motors with flange dimensions also according to all international standards.

The pumps have been constructed in such a way that access to all rotating parts takes place without having to remove the pump from the piping.

All ESL pumps are equipped with mechanical shaft seal for maximum life and minimum energy loss.

The pump can be equipped with an air-driven or electric driven priming device.

The impellers, of which are with double curved blades, ensure high efficiencies and low NPSH-values.

A variety of applications within District Energy and Utility services

- Hot water circulation
- Fresh water circulation
- Refrigeration
- HVAC
- Hydrophore pump
- Cooling water



Material specification

Materials	A
Pump casing	Cast Iron (GG20)
Impeller	Bronze (RG10)
Sealing ring	Bronze (RG10)
Rear cover	Cast iron (GG20)
Shaft	Duplex St. steel (1.4460)
Shaft seal	Mechanical

Alternative materials include:

- Cast Iron
- Ductile Iron
- Bronze
- NiAl-Bronze
- Stainless Steel
- Super Duplex Stainless Steel

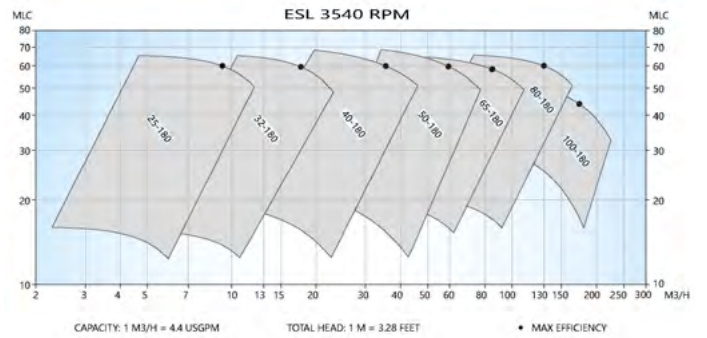
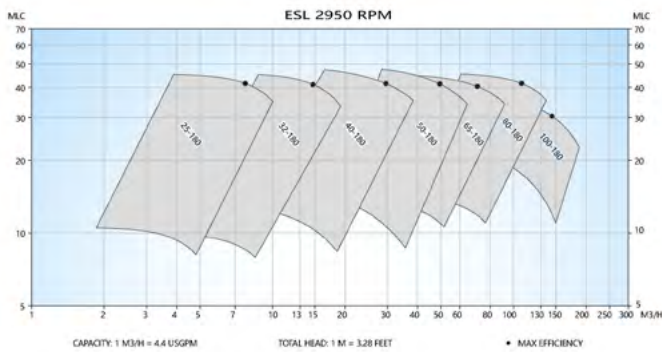

Design Details

ESL In-line Pumps with Ø 180 or Ø 190 Impeller

The dimension of the suction flange is identical with the dimension of the discharge flange. The line through inlet and outlet is flush with the centre line of the shaft. The pumps are equipped with one impeller wear ring.

Monobloc without Bearings

A sturdy standard pump for clean liquids. Compact design because the rear cover is part of the motor bracket. Dismantling of rotating parts is possible without removing the pump casing from the piping. The ESL in-line pump can be mounted horizontally on request.

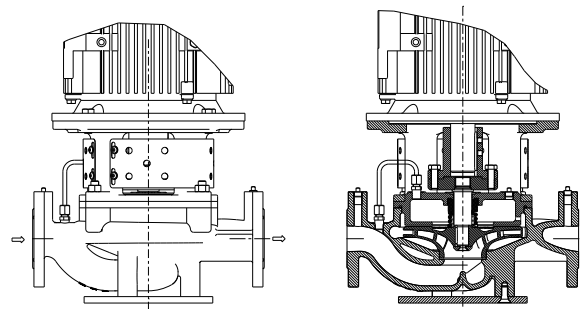

ESL 25-32-40-50

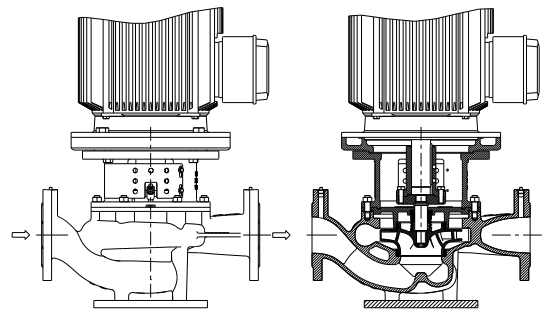

ESL 65-80-100