

Electric Motors

# IE4 Motors



IE4 Motors

**HOYER**  
MOTORS



# HOYER

EXCEEDING EXPECTATIONS

Hoyer Motors is an international supplier of high-end electric motors. Headquartered in Denmark and China, we are represented through sales offices and distributors worldwide. We pride ourselves of being an elite manufacturing enterprise with the highest attention to service and flexibility – a company where dedication, competitiveness and reliability are second to none.

We have selected focus on the segments Marine, HVAC, Industrial Pumps, Oil & Gas, Wind and HPU. Through strong partnerships with market leading industrial OEM's within these segments, we are able to offer a unique setup and industrial insight. We add value by understanding the business and markets of our customers.

At Hoyer Motors, meeting agreements is as natural as breathing air. We believe in trustworthy partnerships with our customers and always meet our obligations on deliveries, documentation and product quality. This is what we mean by Exceeding Expectations.

## General information

The Hoyer Motors IE4 range offers premium efficiency and is manufactured according to international standards under IEC 60034-30 and fulfills the requirement of the EC Directive 2014/35/EU, 2009/125/EC and ecodesign for energy related products 2009/640/EC and 4/2014EU and future (EU) 2019/1781/EC.

Hoyer motors are used across the world and have a proven quality, high reliability and performance.

Product information	
Series:	HMA4 / HMC4 IEC size 80-355. Aluminium or cast iron ribbed housing, cast iron terminal box and bearing shield
Standards:	IEC 60034 series, IEC60072-1 and EN 50347
Cooling:	IC411 (TEFC). Other cooling types on request
Frame material:	Aluminium (HMA4) or cast iron (HMC4)
Mounting form:	B3, B5, B14, B34 and B35
Terminal box:	Terminal box on top
Power range:	0.37-315 kW
Duty:	S1, S2-S10 on request
Ambient temperature:	-20° to +40°. Other temperature demands on request
Altitude:	Up to 1000m above sea level. Higher altitude on request
Voltage at 50Hz:	230/400V ± 10% Δ/Y ( Up to 3 kW), 400/690V ± 10% Δ/Y (Above 3 kW) at 50Hz. Other voltages on request
Voltage at 60Hz:	280/440V, 480V ± 10% Δ/Y (Up to 3kW), 440, 480/830V ± 10% Δ/Y (Above 3kW) at 60Hz. Other voltages on request
Frequency range:	50-60Hz as standard. 5-100Hz on request
Vibration level:	Grade A
Efficiency:	IE4 according to IEC 60034-30
Drain plugs:	Plastic
Numbers of poles:	2, 4 and 6
Protection class:	IP55. Other IP classes on request
Insulation class / temperature rise:	F / B. Insulation class H on request
Coating:	Hoyer standard, C3L. Other coatings on request
Color:	RAL 9005 low gloss. Other colors on request
Winding protection:	3x PTC 155°C
Blind plugs:	Plastic
Supply:	DOL or frequency converter duty (VFD)

Options
Other mounting arrangements
Tropical insulation
Heater in windings
PT 100 in windings
PT 100 in bearings
Current insulated bearings for VFD duty
Cable glands

# Hoyer IE4 Electric Motors

## Energy efficiency and MEPS

Energy efficiency is a main focus area related to CO2 emissions and industrial pollution. Across borders legislation and Minimum Energy Performance Standards (MEPS) are put into force to improve the efficiency of electric motors. The European MEPS is defined in the Ecodesign directive and Hoyer IE4 fulfils these future regulations. In theory a higher motor efficiency will result in electrical energy savings.

In addition to lower emissions the financial return of investment is also considerable. With a service life of 10-15 years the energy consumption of an electric motor often accounts for more than 90% of the total cost of ownership. Therefore, the payback time for an IE4 motor compared to an IE3 is in many cases less than 2-3 years depending on motor size and operating hours. *E.g. a 55kW 4 pole motor operating 4000 hours a year will have a payback time of 2.5 years.*

Efficiency curves for IE4, IE3, IE2 and IE1 4 pole 50Hz electric motors

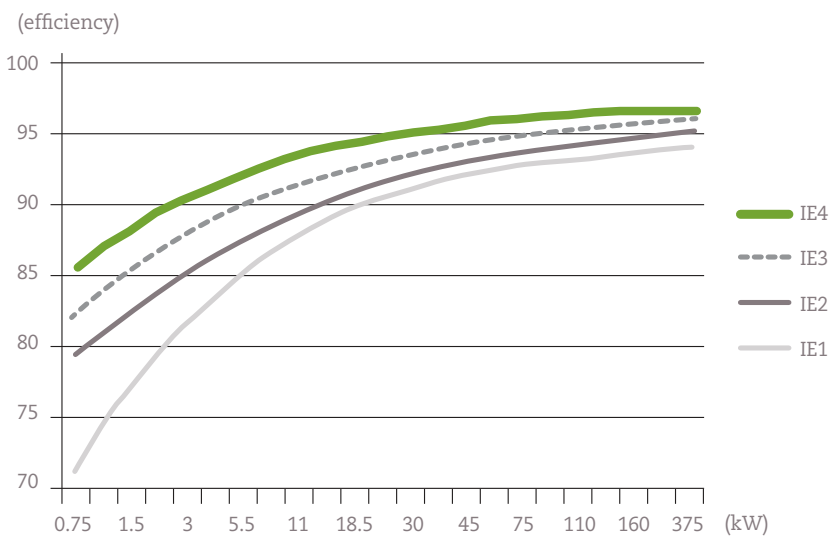

## Application information

Hoyer IE4 electric motors are used within a wide variety of applications. Some of the typical applications are:

- Fans and HVAC
- Hydraulics
- Pumps
- Compressors and cooling

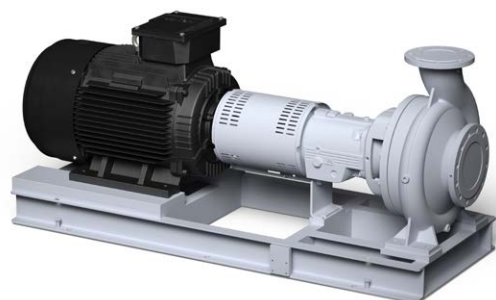

## Bearings and blind plugs

The Hoyer IE4 range is equipped with premium quality bearings. All motor sizes have fixed bearing in D.E. as standard and oil seal rings in D.E. and N.D.E.

Motors size ≤ 180 come with closed bearings greased for life.

Motors size >200 come with re-greaseable open bearings.

Bearing grease in temperature range -30°C/+150°C is used in both closed and open bearings.

As standard all motors are equipped with blind plugs.

### Bearings

Motor type	Drive End		None drive end	
	2 pole	4,6 pole	2 pole	4,6 pole
HMA4 80	6204-2Z/C3		6203-2Z/C3	
HMA4 90	6205-2Z/C3		6204-2Z/C3	
HMA4 100	6306-2Z/C3		6205-2Z/C3	
HMA4 112	6306-2Z/C3		6205-2Z/C3	
HMA4 132	6208-2Z/C3		6206-2Z/C3	
HMA4 160	6209-2Z/C3		6209-2Z/C3	
HMA4 180	6211-2Z/C3	6311-2Z/C3	6211-2Z/C3	
HMC4 160	6209-2Z/C3		6209-2Z/C3	
HMC4 180	6211-2Z/C3	6311-2Z/C3	6211-2Z/C3	
HMC4 200	6212/C3	6312/C3	6212/C3	
HMC4 225	6312/C3	6313/C3	6312/C3	
HMC4 250	6313/C3	6314/C3	6313/C3	
HMC4 280	6314/C3	6317/C3	6314/C3	
HMC4 315	6317/C3	6319/C3 NU319	6317/C3	6319/C3
HMC4 355	6319/C3	6322/C3 NU322	6319/C3	6322/C3

### Blind plugs

Motor type	Main Blind caps	Accs. Blind caps
HMA4 80	2xM20x1,5	1xM12x1,5
HMA4 90	2xM25x1,5	1xM20x1,5
HMA4 100	2xM25x1,5	1xM20x1,5
HMA4 112	2xM25x1,5	1xM20x1,5
HMA4 132	2xM32x1,5	1xM20x1,5
HMA4 160	2xM40x1,5	2xM20x1,5
HMA4 180	2xM40x1,5	2xM20x1,5
HMC4 160	2xM40x1,5	2xM20x1,5
HMC4 180	2xM40x1,5	2xM20x1,5
HMC4 200	2xM50x1,5	2xM20x1,5
HMC4 225	2xM50x1,5	2xM20x1,5
HMC4 250	2xM63x1,5	2xM20x1,5
HMC4 280	2xM63x1,5	2xM20x1,5
HMC4 315	2xM63x1,5	2xM20x1,5
HMC4 355	2xM72x2,0	2xM20x1,5

## Supply by frequency converter

Hoyer IE4 motors are as standard prepared for frequency converter (VFD) duty. By using a Hoyer Motors IE4 motor together with a premium VFD there can be several benefits including better process control, energy savings and a reduced starting current. It can further reduce stress on mechanical equipment and the electrical supply network.

Depending on the customer application Hoyer Motors refers to IEC 60034-17 and IEC TS 60034-25 when operating an electric motor with a VFD. Several parameters are to be considered.

- VFD output voltages spike levels
- VFD filters
- VFD switching frequency
- Motor insulation system
- Motor bearings e.g. current insulated bearings

A switching frequency of 2-8 kHz is recommended to ensure the best motor insulation system lifetime.

Hoyer Drives & Controls offers complete motor and VFD solutions including integrated and stand-alone drives.

# Hoyer IE4 Electric Motors

## Rating plate

### Name plate

<b>IE4</b>		<b>HOYER</b>				<b>CE</b>	
		www.hoyermotors.com					
Type: HMC4 250M-4			Serial no:			3~Motor	
D.E. 6314/C3		N.D.E. 6313/C3		40°C	422 Kg	IP 55	INS: F Δ T: B
V. Δ/Y	Hz	kW	rpm	A. Δ/Y	Cos φ	Duty	
400/690	50	55	1480	97,5/56,5	0,85	S1	
480/830	60	66	1780	97,5/56,5	0,85	S1	
IE4 eff. at: 400/690V 50Hz		1/1	95,7%	3/4	95,6%	1/2	94,8%
IM: B35		YY/WW: 20/35					IEC 60034-1

## Rating tables

Rating factors for power output kW at different ambient temperatures and altitudes are found below.

### Ambient temperature

Ambient temperature °C	30°	35°	40°	45°	50°	55°	60°
Factor (kW)	1,05	1,02	1,00	0,97	0,93	0,87	0,82

### Altitude

Altitude m	1000 m	1500 m	2000 m	2500 m	3000 m	3500 m	4000 m
Factor (kW)	1,00	0,98	0,95	0,91	0,87	0,83	0,78

# Hoyer IE4 Electric Motors

**B3**

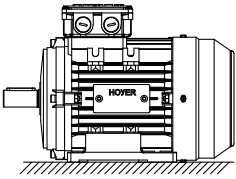

**B6**

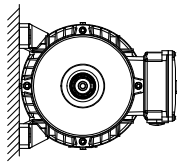

**B7**

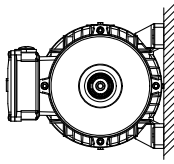

**B8**

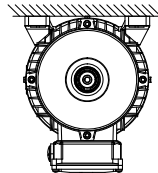

**V5**

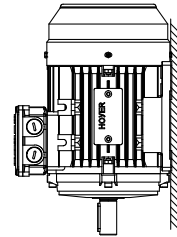

**V6**

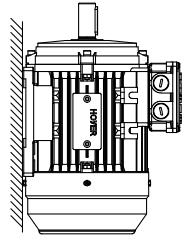

**B5**

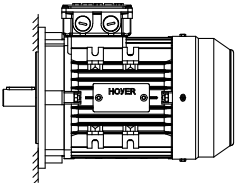

**V1**

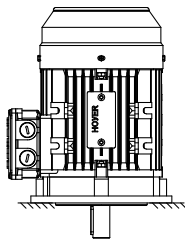

**V3**

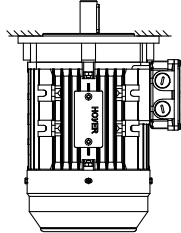

**B35**

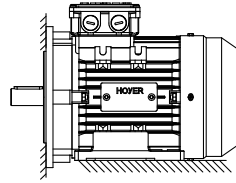

**V15**

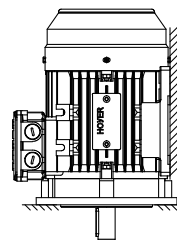

**V35**

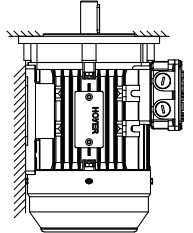

**B14**

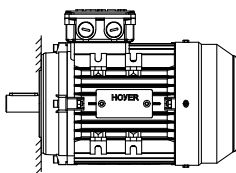

**V18**

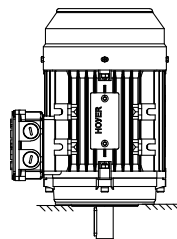

**V19**

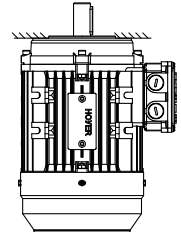

**B34**

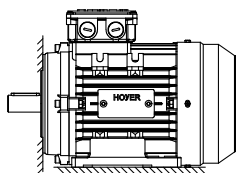

**V17**

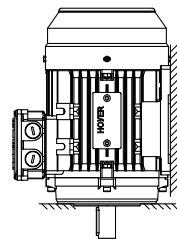

**V37**

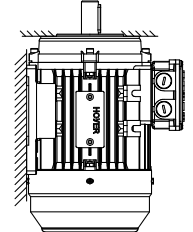

\*Important notice: V3 mounting with standard housing only accepted up to frame size 250. Motors frame size 280 and up need special housing and flange.

## IE4 / 2 pole

Motor type	Power kW	Speed rpm	Current at 400V		Efficiency (%)			Pf cos φ	Torque			IM J(kgm <sup>2</sup> )	Weight kg
			I <sub>N</sub> (A)	I <sub>s</sub> /I <sub>N</sub>	1/1 load	3/4 load	1/2 load		T <sub>N</sub>	T <sub>s</sub> /T <sub>N</sub>	T <sub>M</sub> /T <sub>N</sub>		

### Aluminium motors

HMA4 80M1-2	0,75	2870	1,66	7,30	83,5	84,6	83,1	0,78	2,50	4,60	3,90	0,0010	12,0
HMA4 80M2-2	1,10	2880	2,48	8,30	85,2	85,3	83,7	0,75	3,65	4,80	4,20	0,0010	13,0
HMA4 90S-2	1,50	2900	2,85	8,80	86,5	87,3	87,3	0,88	4,95	3,10	3,70	0,0020	16,0
HMA4 90L-2	2,20	2900	4,10	9,50	88,0	89,1	88,9	0,88	7,25	3,30	3,70	0,0030	19,0
HMA4 100L-2	3,00	2910	5,60	11,4	89,1	88,9	87,5	0,87	9,85	5,10	4,60	0,0050	27,0
HMA4 112M-2	4,00	2920	7,35	9,20	90,0	89,9	88,0	0,87	13,2	3,00	3,60	0,0140	37,0
HMA4 132S1-2	5,50	2930	9,80	9,60	90,9	90,7	89,9	0,89	18,0	3,20	3,80	0,0280	45,0
HMA4 132S2-2	7,50	2930	13,2	10,2	91,7	91,2	90,5	0,89	24,4	3,20	3,90	0,0280	50,0
HMA4 160M1-2	11,0	2940	19,4	7,80	92,6	92,5	91	0,88	35,5	2,20	3,70	0,0750	98,0
HMA4 160M2-2	15,0	2940	26,5	8,20	93,3	93,1	92,0	0,88	48,5	2,20	3,80	0,0820	108
HMA4 160L-2	18,5	2940	32,0	8,10	93,7	93,5	92,0	0,89	60,0	2,20	3,80	0,0880	130
HMA4 180M-2	22,0	2960	38,5	8,00	94,0	93,8	92,5	0,88	71,0	2,50	3,20	0,2190	150

### Cast iron motors

HMC4 160M1-2	11,0	2940	19,4	7,80	92,6	92,5	91,0	0,88	35,5	2,20	3,70	0,0750	130
HMC4 160M2-2	15,0	2940	26,5	8,20	93,3	93,1	92,0	0,88	48,5	2,20	3,80	0,0820	150
HMC4 160L-2	18,5	2940	32,0	8,10	93,7	93,5	92,0	0,89	60,0	2,20	3,80	0,0880	160
HMC4 180M-2	22,0	2960	38,5	8,00	94,0	93,8	92,5	0,88	71,0	2,50	3,20	0,2190	200
HMC4 200L1-2	30,0	2960	51,5	9,70	94,5	94,4	93,5	0,89	97,0	2,70	3,40	0,1930	258
HMC4 200L2-2	37,0	2960	62,5	9,30	94,8	95,0	94,7	0,90	120	2,70	3,50	0,2030	278
HMC4 225M-2	45,0	2970	76,0	9,30	95,0	94,9	94,4	0,90	144	2,50	3,50	0,4110	358
HMC4 250M-2	55,0	2980	94,5	9,00	95,3	95,1	94,0	0,88	176	2,40	3,10	0,4350	452
HMC4 280S-2	75,0	2980	128	8,60	95,6	95,2	94,3	0,89	240	2,50	3,40	0,7430	544
HMC4 280M-2	90,0	2980	152	8,60	95,8	95,6	94,8	0,89	290	2,30	3,20	0,8220	620
HMC4 315S-2	110	2980	184	7,70	96,0	95,8	94,9	0,90	355	2,20	3,00	1,6400	977
HMC4 315M-2	132	2980	220	7,70	96,2	96,0	95,0	0,90	425	2,20	2,90	1,7800	1056
HMC4 315L1-2	160	2980	265	7,80	96,3	96,2	95,1	0,90	515	2,30	3,20	1,9700	1150
HMC4 315L2-2	200	2980	330	8,40	96,5	96,3	95,4	0,90	640	2,30	3,30	2,3100	1280
HMC4 355M-2	250	2980	415	8,30	96,5	96,3	95,4	0,90	800	2,00	2,30	3,9000	1780
HMC4 355L-2	315	2980	525	8,30	96,5	96,2	95,3	0,90	1000	2,00	2,30	4,0100	1966

Data at 400V 50Hz

At 230V 50Hz the current is  $\sqrt{3}$  x current at 400V and at 690V the current is current at 400V /  $\sqrt{3}$ . All other data are identical.

## IE4 / 4 pole

Motor type	Power kW	Speed rpm	Current at 400V		Efficiency (%)			Pf cos φ	Torque			IM J(kgm <sup>2</sup> )	Weight kg
			I <sub>N</sub> (A)	I <sub>s</sub> /I <sub>N</sub>	1/1 load	3/4 load	1/2 load		T <sub>N</sub>	T <sub>s</sub> /T <sub>N</sub>	T <sub>M</sub> /T <sub>N</sub>		

## Aluminium motors

HMA4 80M2-4	0,75	1440	1,80	7,90	85,7	84,5	81,5	0,70	4,95	5,00	4,30	0,0050	11,0
HMA4 90S-4	1,10	1440	2,40	7,60	87,2	87,5	85,3	0,76	7,25	3,80	3,80	0,0070	14,0
HMA4 90L-4	1,50	1440	3,25	7,70	88,2	88,5	86,5	0,76	9,90	3,00	3,50	0,0080	17,0
HMA4 100L1-4	2,20	1460	4,60	9,80	89,5	88,2	86,6	0,77	14,4	4,10	4,10	0,0090	26,0
HMA4 100L2-4	3,00	1460	6,20	10,6	90,4	89,6	88,3	0,77	19,6	4,10	4,40	0,0100	34,0
HMA4 112M-4	4,00	1440	8,15	8,50	91,1	90,4	90,0	0,78	26,5	3,70	3,60	0,0190	37,0
HMA4 132S-4	5,50	1460	10,8	9,30	91,9	91,2	90,0	0,80	36,0	3,20	3,30	0,0420	45,0
HMA4 132M-4	7,50	1460	14,8	10,6	92,6	92,0	91,0	0,79	49,0	3,60	4,00	0,0510	63,0
HMA4 160M-4	11,0	1480	20,6	8,80	93,3	93,1	92,2	0,83	71,0	3,30	3,40	0,1340	106
HMA4 160L-4	15,0	1480	28,0	9,00	93,9	93,8	92,9	0,83	97,0	3,60	3,80	0,1320	124
HMA4 180M-4	18,5	1480	34,0	7,90	94,2	94,0	93,0	0,83	120	2,30	3,80	0,2020	162
HMA4 180L-4	22,0	1480	40,5	8,50	94,5	94,3	93,3	0,83	142	2,30	3,70	0,2350	186

## Cast iron motors

HMC4 160M-4	11,0	1480	20,6	8,80	93,3	93,1	92,2	0,83	71,0	3,30	3,40	0,1340	136
HMC4 160L-4	15,0	1480	28,0	9,00	93,9	93,8	92,9	0,83	97,0	3,60	3,80	0,1320	154
HMC4 180M-4	18,5	1480	34,0	7,90	94,2	94,0	93,0	0,83	120	2,30	3,80	0,2020	192
HMC4 180L-4	22,0	1480	40,5	8,50	94,5	94,3	93,3	0,83	142	2,30	3,70	0,2350	216
HMC4 200L-4	30,0	1480	53,5	9,50	94,9	95,0	94,7	0,85	194	2,60	3,40	0,3110	265
HMC4 225S-4	37,0	1480	64,5	9,00	95,2	95,3	94,9	0,87	238	2,40	2,80	0,6120	344
HMC4 225M-4	45,0	1480	77,5	8,90	95,4	95,5	95,2	0,88	290	2,40	2,60	0,6790	382
HMC4 250M-4	55,0	1480	97,5	8,80	95,7	95,6	94,8	0,85	355	2,40	2,90	0,8410	472
HMC4 280S-4	75,0	1480	132	8,20	96,0	95,9	95,2	0,85	480	2,20	2,70	1,5300	614
HMC4 280M-4	90,0	1480	158	8,20	96,1	96,0	95,0	0,86	580	2,20	2,60	1,7700	662
HMC4 315S-4	110	1490	190	8,10	96,3	96,2	95,2	0,87	705	2,20	2,80	4,0100	925
HMC4 315M-4	132	1490	224	8,10	96,4	96,2	95,3	0,88	845	2,10	2,60	3,7400	1068
HMC4 315L1-4	160	1490	270	7,90	96,6	96,4	95,8	0,88	1020	2,20	2,60	7,5600	1116
HMC4 315L2-4	200	1490	335	7,90	96,7	96,5	95,8	0,89	1280	2,10	3,00	5,1600	1170
HMC4 355M-4	250	1490	420	8,00	96,7	96,5	95,7	0,89	1600	2,30	3,20	8,0300	1750
HMC4 355L-4	315	1490	530	8,00	96,7	96,5	95,7	0,89	2020	2,10	2,60	8,7600	1880

Data at 400V 50Hz

At 230V 50Hz the current is  $\sqrt{3}$  x current at 400V and at 690V the current is current at 400V /  $\sqrt{3}$ . All other data are identical.

## IE4 / 6 pole

Motor type	Power kW	Speed rpm	Current at 400V		Efficiency (%)			Pf cos φ	Torque			IM J(kgm <sup>2</sup> )	Weight kg
			I <sub>N</sub> (A)	I <sub>s</sub> /I <sub>N</sub>	1/1 load	3/4 load	1/2 load		T <sub>N</sub>	T <sub>s</sub> /T <sub>N</sub>	T <sub>M</sub> /T <sub>N</sub>		

### Aluminium motors

HMA4 90S-6	0,75	960	1,88	4,20	82,7	82,1	78,3	0,70	7,50	2,00	2,50	0,0050	14,0
HMA4 90L-6	1,10	960	2,65	4,10	84,5	84,1	77,6	0,71	11,0	2,00	2,50	0,0070	15,0
HMA4 100L-6	1,50	960	3,60	4,70	85,9	85,8	83,0	0,70	15,0	2,00	2,60	0,0080	25,0
HMA4 112M-6	2,20	960	4,80	5,00	87,4	87,4	85,0	0,76	21,8	2,00	2,30	0,0160	35,0
HMA4 132S-6	3,00	980	6,50	7,10	88,6	88,6	87,1	0,75	29,5	2,50	2,50	0,0380	60,0
HMA4 132M1-6	4,00	980	8,60	7,50	89,5	89,3	88,0	0,75	39,0	2,80	3,10	0,0600	63,0
HMA4 132M2-6	5,50	980	11,6	7,50	90,5	90,6	89,9	0,76	54,0	3,00	3,10	0,0650	66,0
HMA4 160M-6	7,50	970	15,8	7,00	91,3	91,0	90,2	0,75	74,0	2,50	2,80	0,1400	130
HMA4 160L-6	11,0	980	23,0	7,00	92,3	92,2	91,1	0,75	108	3,00	3,10	0,2600	150
HMA4 180L-6	15,0	980	30,0	8,50	92,9	92,7	90,7	0,78	146	3,00	3,40	0,3800	170

### Cast iron motors

HMC4 160M-6	7,50	970	15,8	7,00	91,3	91,0	90,2	0,75	74,0	2,50	2,80	0,1400	160
HMC4 160L-6	11,0	980	23,0	7,00	92,3	92,2	91,1	0,75	108	3,00	3,10	0,2600	180
HMC4 180L-6	15,0	980	30,0	8,50	92,9	92,7	90,7	0,78	146	3,00	3,40	0,3800	200
HMC4 200L1-6	18,5	980	37,5	8,60	93,4	93,1	92,4	0,76	180	2,90	3,60	0,3800	255
HMC4 200L2-6	22,0	980	46,0	9,60	93,7	93,6	92,5	0,74	214	3,20	4,00	0,4400	286
HMC4 225M-6	30,0	980	56,0	8,10	94,2	94,1	93,4	0,82	290	2,40	2,70	0,7300	362
HMC4 250M-6	37,0	980	69,0	9,30	94,5	94,6	93,9	0,82	360	2,90	3,80	1,3100	474
HMC4 280S-6	45,0	980	82,5	9,40	94,8	94,7	93,9	0,83	440	2,90	3,60	1,7500	572
HMC4 280M-6	55,0	980	102	9,90	95,1	95,0	94,2	0,82	535	3,30	3,90	1,9900	644
HMC4 315S-6	75,0	980	136	7,20	95,4	95,4	94,9	0,84	730	1,80	2,60	3,8600	920
HMC4 315M-6	90,0	990	160	7,20	95,6	95,7	95,1	0,85	870	1,80	2,60	4,9500	992
HMC4 315L1-6	110	990	194	6,90	95,8	95,9	95,5	0,85	1060	1,80	2,50	5,7600	1120
HMC4 315L2-6	132	990	236	7,90	96,0	95,9	95,2	0,84	1280	2,00	2,60	5,7900	1230
HMC4 355M1-6	160	990	290	7,90	96,2	95,9	95,3	0,83	1540	2,00	2,70	9,9600	1657
HMC4 355M2-6	200	995	355	7,60	96,3	96,1	95,5	0,84	1920	1,90	2,50	11,500	1763
HMC4 355L-6	250	995	445	8,2	96,5	96,4	95,8	0,84	2400	2,20	2,70	12,600	1831

Data at 400V 50Hz

At 230V 50Hz the current is  $\sqrt{3}$  x current at 400V and at 690V the current is current at 400V /  $\sqrt{3}$ . All other data are identical.

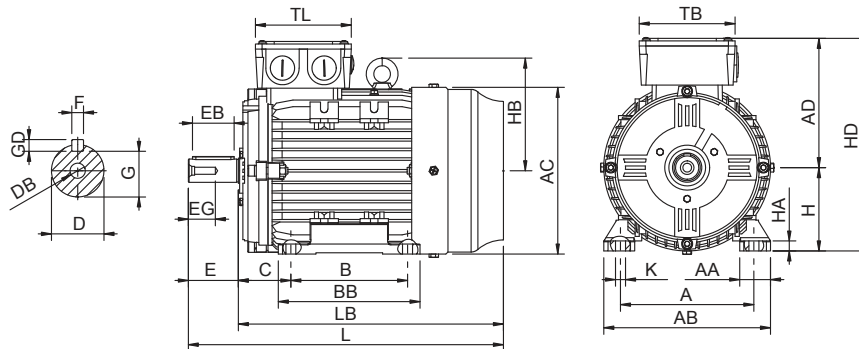

Motor type	Pole	A	AA	AB	AC	AD	B	BB	C	D	DB	E	EB	EG	F	G	GD	H	HA	HB	HD	K	L	LB	TB	TL
------------	------	---	----	----	----	----	---	----	---	---	----	---	----	----	---	---	----	---	----	----	----	---	---	----	----	----

## Aluminium motors

HMA4 80M	2	125	32	154	157	123	100	125	50	19	M6	40	32	16	6	15,5	6	80	10		203	10	296	256	110	110
HMA4 80M	4	125	32	154	157	123	100	125	50	19	M6	40	32	16	6	15,5	6	80	10		203	10	331	291	110	110
HMA4 90S	2,4,6	140	37	180	175	146	100	128	56	24	M8	50	40	24	8	20	7	90	10		236	10	324	274	115	115
HMA4 90L	2,4,6	140	37	180	175	146	125	153	56	24	M8	50	40	24	8	20	7	90	10	121	236	10	349	299	115	115
HMA4 100L	2,4	160	37	200	199	159	140	170	63	28	M10	60	50	28	8	24	7	100	12	135	259	12	418	358	115	115
HMA4 100L	6	160	37	200	199	159	140	170	63	28	M10	60	50	28	8	24	7	100	12	135	259	12	374	314	115	115
HMA4 112M	2,4,6	190	47	230	222	169	140	170	70	28	M10	60	50	28	8	24	7	112	12	146	281	12	381	321	115	115
HMA4 132S	2,4,6	216	54	264	260	192	140	172	89	38	M12	80	70	30	10	33	8	132	15	180	324	12	475	395	138	138
HMA4 132M	2,4,6	216	54	264	260	192	178	210	89	38	M12	80	70	30	10	33	8	132	15	180	324	12	513	433	138	138
HMA4 160M	2,4,6	254	62	314	314	238	210	260	108	42	M16	110	90	38	12	37	8	160	22	207	398	14,5	612	502	181	181
HMA4 160L	2,4,6	254	62	314	314	238	254	304	108	42	M16	110	90	38	12	37	8	160	22	207	398	14,5	656	546	181	181
HMA4 180M	2,4,6	279	70	347	355	256	241	304	121	48	M16	110	100	42	14	42,5	9	180	25	227	436	14,5	685	575	181	181
HMA4 180L	4,6	279	70	347	355	256	279	342	121	48	M16	110	100	42	14	42,5	9	180	25	227	436	14,5	723	613	181	181

# IE4 / B3

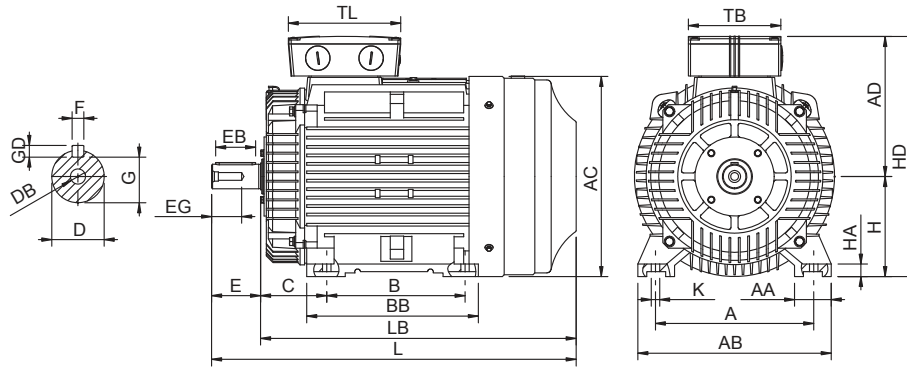

Motor type	Pole	A	AA	AB	AC	AD	B	BB	C	D	DB	E	EB	EG	F	G	GD	H	HA	HB	HD	K	L	LB	TB	TL
------------	------	---	----	----	----	----	---	----	---	---	----	---	----	----	---	---	----	---	----	----	----	---	---	----	----	----

## Cast iron motors

HMC4 160M	2,4,6	64	254	312	314	253	210	260	108	42	M16	110	90	38	12	37	8	160	20	140	413	14,5	610	500	160	200
HMC4 160L	2,4,6	64	254	312	314	253	254	304	108	42	M16	110	90	38	12	37	8	160	20	140	413	14,5	654	544	160	200
HMC4 180M	2,4,6	68	279	348	355	269	241	311	121	48	M16	110	100	42	14	42,5	9	180	22	156	449	14,5	684	574	160	200
HMC4 180L	4,6	68	279	348	355	269	279	349	121	48	M16	110	100	42	14	42,5	9	180	22	156	449	14,5	722	612	160	200
HMC4 200L	2,4,6	70	318	384	397	296	305	369	133	55	M20	110	100	52	16	49	10	200	25	170	496	18,5	774	664	200	250
HMC4 225S	4,6	79	356	426	445	319	286	361	149	60	M20	140	125	58	18	53	11	225	28	195	544	18,5	821	681	200	250
HMC4 225M	2	79	356	426	445	319	311	386	149	55	M20	110	100	58	16	49	10	225	28	195	544	18,5	816	706	200	250
HMC4 225M	4,6	79	356	426	445	319	311	386	149	60	M20	140	125	58	18	53	11	225	28	195	544	18,5	846	706	200	250
HMC4 250M	2	97	406	484	484	370	349	445	168	60	M20	140	125	58	18	53	11	250	32	215	620	24	911	771	211	271
HMC4 250M	4,6	97	406	484	484	370	349	445	168	65	M20	140	125	58	18	58	11	250	32	215	620	24	911	771	211	271
HMC4 280S	2	85	457	542	546	400	368	485	190	65	M20	140	125	58	18	58	11	280	30	349	680	24	965	825	211	271
HMC4 280S	4,6	85	457	542	546	400	368	485	190	75	M20	140	125	58	20	67,5	12	280	30	349	680	24	965	825	211	271
HMC4 280M	2	85	457	542	546	400	419	536	190	65	M20	140	125	58	18	58	11	280	30	349	680	24	1016	876	211	271
HMC4 280M	4,6	85	457	542	546	400	419	536	190	75	M20	140	125	58	20	67,5	12	280	30	349	680	24	1016	876	211	271
HMC4 315S	2	120	508	628	620	502	406	570	216	65	M20	140	125	58	18	58	11	315	40	417	817	28	1201	1061	300	258
HMC4 315S	4,6	120	508	628	620	502	406	570	216	80	M20	170	140	58	22	71	14	315	40	417	817	28	1231	1061	300	258
HMC4 315M	2	120	508	628	620	502	457	680	216	65	M20	140	125	58	18	58	11	315	40	417	817	28	1311	1171	300	258
HMC4 315M	4,6	120	508	628	620	502	457	680	216	80	M20	170	140	58	22	71	14	315	40	417	817	28	1341	1171	300	258
HMC4 315L	2	120	508	628	620	502	508	680	216	65	M20	140	125	58	18	58	11	315	40	417	817	28	1311	1171	300	258
HMC4 315L	4,6	120	508	628	620	502	508	680	216	80	M20	170	140	58	22	71	14	315	40	417	817	28	1341	1171	300	258
HMC4 355M	2	116	610	726	698	590	560	750	254	75	M20	140	125	46	20	67,5	12	355	40	474	945	28	1501	1361	340	300
HMC4 355M	4,6	116	610	726	698	590	560	750	254	95	M24	170	140	56	25	86	14	355	40	474	945	28	1531	1361	340	300
HMC4 355L	2	116	610	726	698	590	630	750	254	75	M20	140	125	46	20	67,5	12	355	40	474	945	28	1501	1361	340	300
HMC4 355L	4,6	116	610	726	698	590	630	750	254	95	M24	170	140	56	25	86	14	355	40	474	945	28	1531	1361	340	300

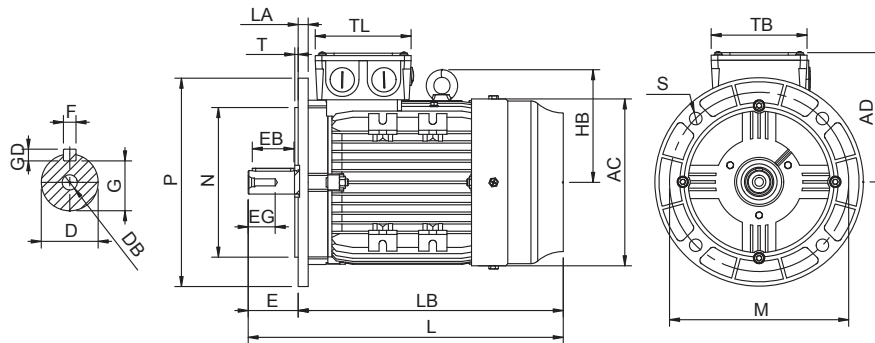

Motor type	Pole	AC	AD	L	LB	HB	TL	TB	D	E	F	G	GD	EB	EG	DB	M	N	P	S	T	LA
------------	------	----	----	---	----	----	----	----	---	---	---	---	----	----	----	----	---	---	---	---	---	----

Aluminium motors

HMA4 80M	2	157	123	296	256		110	110	19	40	6	15,5	6	32	16	M6	165	130	200	4-Ø12	3,5	9,5
HMA4 80M	4	157	123	331	291		110	110	19	40	6	15,5	6	32	16	M6	165	130	200	4-Ø12	3,5	9,5
HMA4 90S	2,4,6	175	146	324	274		115	115	24	50	8	20	7	40	24	M8	165	130	200	4-Ø12	3,5	10
HMA4 90L	2,4,6	175	146	349	299		115	115	24	50	8	20	7	40	24	M8	165	130	200	4-Ø12	3,5	10
HMA4 100L	2,4	199	159	418	358		115	115	28	60	8	24	7	50	28	M10	215	180	250	4-Ø14,5	4	12
HMA4 100L	6	199	159	374	314		115	115	28	60	8	24	7	50	28	M10	215	180	250	4-Ø14,5	4	12
HMA4 112M	2,4,6	222	169	381	321	146	115	115	28	60	8	24	7	50	28	M10	215	180	250	4-Ø14,5	4	12
HMA4 132S	2,4,6	260	192	475	395	180	138	138	38	80	10	33	8	70	30	M12	215	180	250	4-Ø14,5	4	12
HMA4 132M	2,4,6	260	192	513	433	180	138	138	38	80	10	33	8	70	30	M12	265	230	300	4-Ø14,5	4	14
HMA4 160M	2,4,6	314	238	612	502	207	181	181	42	110	12	37	8	90	38	M16	300	250	350	4-Ø18,5	5	15
HMA4 160L	2,4,6	314	238	656	546	207	181	181	42	110	12	37	8	90	38	M16	300	250	350	4-Ø18,5	5	15
HMA4 180M	2,4,6	355	256	685	575	227	181	181	48	110	14	42,5	9	100	42	M16	300	250	350	4-Ø18,5	5	15
HMA4 180L	4,6	355	256	723	613	227	181	181	48	110	14	42,5	9	100	42	M16	300	250	350	4-Ø18,5	5	15

# IE4 / B5

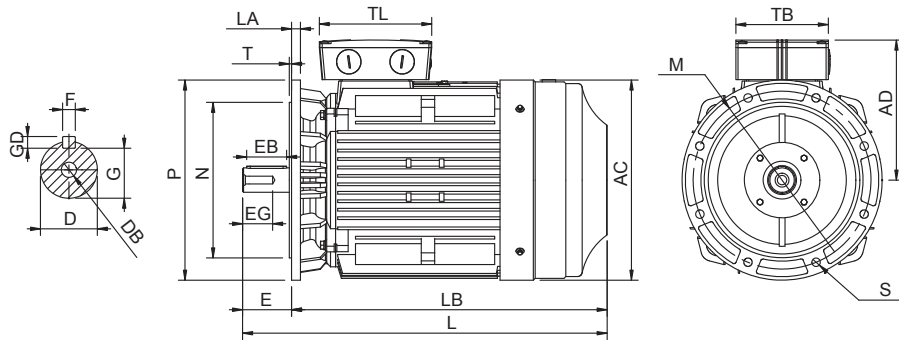

Motor type	Pole	AC	AD	L	LB	HB	TL	TB	D	E	F	G	GD	EB	EG	DB	M	N	P	S	T	LA
------------	------	----	----	---	----	----	----	----	---	---	---	---	----	----	----	----	---	---	---	---	---	----

## Cast iron motors

HMC4 160M	2,4,6	314	253	610	500	140	200	160	42	110	12	37	8	90	38	M16	300	250	350	4-Ø18,5	5	15
HMC4 160L	2,4,6	314	253	654	544	140	200	160	42	110	12	37	8	90	38	M16	300	250	350	4-Ø18,5	5	15
HMC4 180M	2,4,6	355	269	684	574	156	200	160	48	110	14	42,5	9	100	42	M16	300	250	350	4-Ø18,5	5	15
HMC4 180L	4,6	355	269	722	612	156	200	160	48	110	14	42,5	9	100	42	M16	300	250	350	4-Ø18,5	5	15
HMC4 200L	2,4,6	397	296	774	664	170	250	200	55	110	16	49	10	100	52	M20	350	300	400	4-Ø18,5	5	17
HMC4 225S	4,6	445	319	821	681	195	250	200	60	140	18	53	11	125	58	M20	400	350	450	8-Ø18,5	5	20
HMC4 225M	2	445	319	816	706	195	250	200	55	110	16	49	10	100	58	M20	400	350	450	8-Ø18,5	5	20
HMC4 225M	4,6	445	319	846	706	195	250	200	60	140	18	53	11	125	58	M20	400	350	450	8-Ø18,5	5	20
HMC4 250M	2	484	370	911	771	215	271	211	60	140	18	53	11	125	58	M20	500	450	550	8-Ø18,5	5	22
HMC4 250M	4,6	484	370	911	771	215	271	211	65	140	18	58	11	125	58	M20	500	450	550	8-Ø18,5	5	22
HMC4 280S	2	546	400	965	825	349	271	211	65	140	18	58	11	125	58	M20	500	450	550	8-Ø18,5	5	22
HMC4 280S	4,6	546	400	965	825	349	271	211	75	140	20	67,5	12	125	58	M20	500	450	550	8-Ø18,5	5	22
HMC4 280M	2	546	400	1016	876	349	271	211	65	140	18	58	11	125	58	M20	500	450	550	8-Ø18,5	5	22
HMC4 280M	4,6	546	400	1016	876	349	271	211	75	140	20	67,5	12	125	58	M20	500	450	550	8-Ø18,5	5	22
HMC4 315S	2	620	502	1201	1061	417	258	300	65	140	18	58	11	125	58	M20	600	550	660	8-Ø24	6	22
HMC4 315S	4,6	620	502	1231	1061	417	258	300	80	170	22	71	14	140	58	M20	600	550	660	8-Ø24	6	22
HMC4 315M	2	620	502	1311	1171	417	258	300	65	140	18	58	11	125	58	M20	600	550	660	8-Ø24	6	22
HMC4 315M	4,6	620	502	1341	1171	417	258	300	80	170	22	71	14	140	58	M20	600	550	660	8-Ø24	6	22
HMC4 315L	2	620	502	1311	1171	417	258	300	65	140	18	58	11	125	58	M20	600	550	660	8-Ø24	6	22
HMC4 315L	4,6	620	502	1341	1171	417	258	300	80	170	22	71	14	140	58	M20	600	550	660	8-Ø24	6	22
HMC4 355M	2	698	590	1501	1361	474	300	340	75	140	20	67,5	12	125	46	M20	740	680	800	8-Ø24	6	25
HMC4 355M	4,6	698	590	1531	1361	474	300	340	95	170	25	86	14	140	56	M24	740	680	800	8-Ø24	6	25
HMC4 355L	2	698	590	1501	1361	474	300	340	75	140	20	67,5	12	125	46	M20	740	680	800	8-Ø24	6	25
HMC4 355L	4,6	698	590	1531	1361	474	300	340	95	170	25	86	14	140	56	M24	740	680	800	8-Ø24	6	25

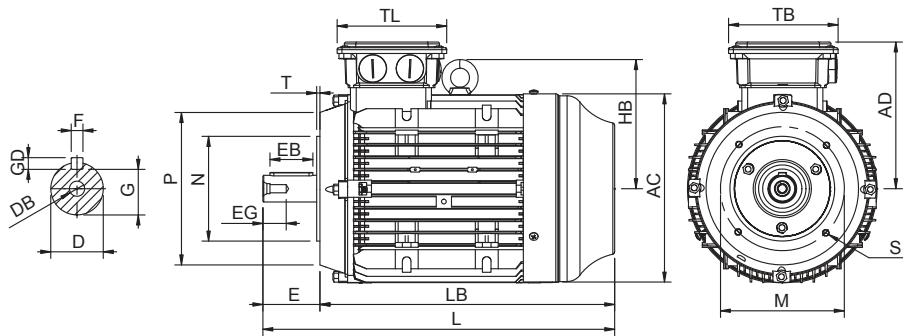

Motor type	Pole	AC	AD	D	DB	E	EB	EG	F	G	GD	L	LB	M	B14 flange					B14 big flange					TB	TL
															N	P	S	T	M	N	P	S	T			

## Aluminium motors

HMA4 80M	2	157	123	19	M6	40	32	16	6	15,5	6	296	256	100	80	120	4-M6	3	130	110	160	4-M8	3,5	110	110
HMA4 80M	4	157	123	19	M6	40	32	16	6	15,5	6	331	291	100	80	120	4-M6	3	130	110	160	4 - M8	3,5	110	110
HMA4 90S	2,4,6	175	146	24	M8	50	40	24	8	20	7	324	274	115	95	140	4-M8	3	130	110	160	4-M8	3,5	115	115
HMA4 90L	2,4,6	175	146	24	M8	50	40	24	8	20	7	349	299	115	95	140	4-M8	3	130	110	160	4-M8	3,5	115	115
HMA4 100L	2,4	199	159	28	M10	60	50	28	8	24	7	418	358	130	110	160	4-M8	3,5	165	130	200	4-M10	4	115	115
HMA4 100L	6	199	159	28	M10	60	50	28	8	24	7	374	314	130	110	160	4-M8	3,5	165	130	200	4 - M10	4	115	115
HMA4 112M	2,4,6	222	169	28	M10	60	50	28	8	24	7	381	321	130	110	160	4-M8	3,5	165	130	200	4-M10	4	115	115
HMA4 132S	2,4,6	260	192	38	M12	80	70	30	10	33	8	475	395	165	130	200	4-M10	3,5	215	180	250	4-M12	4	138	138
HMA4 132M	2,4,6	260	192	38	M12	80	70	30	10	33	8	513	433	165	130	200	4-M10	3,5	215	180	250	4 - M12	4	138	138

# IE4 / B34

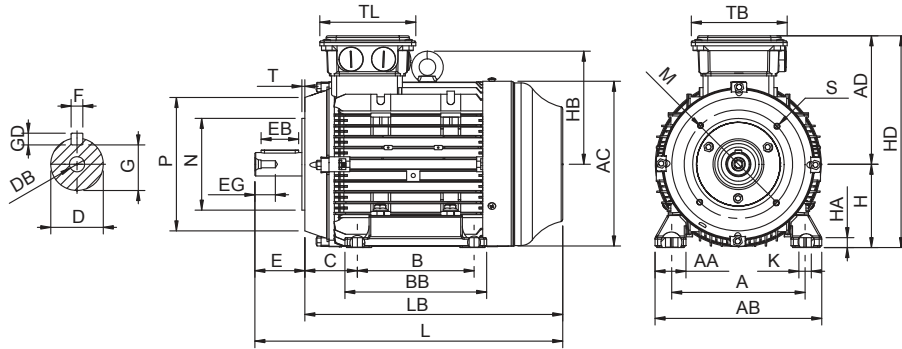

Motor type	Pole	B14 flange															B14 big flange					TB	TL								
		A	AA	AB	AC	AD	B	BB	C	D	DB	E	EB	EG	F	G	GD	H	HA	HD	K			L	LB	M	N	P	S	T	M

## Aluminium motors

HMA4 80M	2	125	32	154	157	123	100	125	50	19	M6	40	32	16	6	15,5	6	80	10	203	10	296	256	100	80	120	4-M6	3	130	110	160	4-M8	3,5	110	110
HMA4 80M	4	125	32	154	157	123	100	125	50	19	M6	40	32	16	6	15,5	6	80	10	203	10	331	291	100	80	120	4-M6	3	130	110	160	4-M8	3,5	110	110
HMA4 90S	2,4,6	140	37	180	175	146	100	128	56	24	M8	50	40	24	8	20	7	90	10	236	10	324	274	115	95	140	4-M8	3	130	110	160	4-M8	3,5	115	115
HMA4 90L	2,4,6	140	37	180	175	146	125	153	56	24	M8	50	40	24	8	20	7	90	10	236	10	349	299	115	95	140	4-M8	3	130	110	160	4-M8	3,5	115	115
HMA4 100L	2,4	160	37	200	199	159	140	170	63	28	M10	60	50	28	8	24	7	100	12	259	12	418	358	130	110	160	4-M8	3,5	165	130	200	4-M10	4	115	115
HMA4 100L	6	160	37	200	199	159	140	170	63	28	M10	60	50	28	8	24	7	100	12	259	12	374	314	130	110	160	4-M8	3,5	165	130	200	4-M10	4	115	115
HMA4 112M	2,4,6	190	47	230	222	169	140	170	70	28	M10	60	50	28	8	24	7	112	12	281	12	381	321	130	110	160	4-M8	3,5	165	130	200	4-M10	4	115	115
HMA4 132S	2,4,6	216	54	264	260	192	140	172	89	38	M12	80	70	30	10	33	8	132	15	324	12	475	395	165	130	200	4-M10	3,5	215	180	250	4-M12	4	138	138
HMA4 132M	2,4,6	216	54	264	260	192	178	210	89	38	M12	80	70	30	10	33	8	132	15	324	12	513	433	165	130	200	4-M10	3,5	215	180	250	4-M12	4	138	138

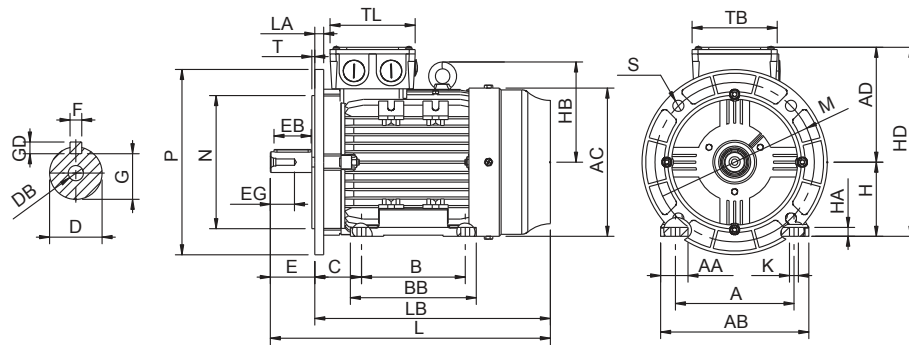

Motor type	Pole	A	AA	AB	AC	AD	B	BB	C	D	DB	E	EB	EG	F	G	GD	H	HA	HB	HD	K	L	LA	LB	M	N	P	S	T	TB	TL
------------	------	---	----	----	----	----	---	----	---	---	----	---	----	----	---	---	----	---	----	----	----	---	---	----	----	---	---	---	---	---	----	----

Aluminium motors

HMA4 80M	2	125	32	154	157	123	100	125	50	19	M6	40	32	16	6	15,5	6	80	10	203	10	296	9,5	256	165	130	200	4-Ø12	3,5	110	110	
HMA4 80M	4	125	32	154	157	123	100	125	50	19	M6	40	32	16	6	15,5	6	80	10	203	10	331	9,5	291	165	130	200	4-Ø12	3,5	110	110	
HMA4 90S	2,4,6	140	37	180	175	146	100	128	56	24	M8	50	40	24	8	20	7	90	10	236	10	324	10	274	165	130	200	4-Ø12	3,5	115	115	
HMA4 90L	2,4,6	140	37	180	175	146	125	153	56	24	M8	50	40	24	8	20	7	90	10	236	10	349	10	299	165	130	200	4-Ø12	3,5	115	115	
HMA4 100L	2,4	160	37	200	199	159	140	170	63	28	M10	60	50	28	8	24	7	100	12	259	12	418	12	358	215	180	250	4-Ø14,5	4	115	115	
HMA4 100L	6	160	37	200	199	159	140	170	63	28	M10	60	50	28	8	24	7	100	12	259	12	374	12	314	215	180	250	4-Ø14,5	4	115	115	
HMA4 112M	2,4,6	190	47	230	222	169	140	170	70	28	M10	60	50	28	8	24	7	112	12	146	281	12	381	12	321	215	180	250	4-Ø14,5	4	115	115
HMA4 132S	2,4,6	216	54	264	260	192	140	172	89	38	M12	80	70	30	10	33	8	132	15	180	324	12	475	12	395	215	180	250	4-Ø14,5	4	138	138
HMA4 132M	2,4,6	216	54	264	260	192	178	210	89	38	M12	80	70	30	10	33	8	132	15	180	324	12	513	14	433	265	230	300	4-Ø14,5	4	138	138
HMA4 160L	2,4,6	254	62	314	314	238	254	304	108	42	M16	110	90	38	12	37	8	160	22	207	398	14,5	656	15	546	300	250	350	4-Ø18,5	5	181	181
HMA4 160M	2,4,6	254	62	314	314	238	210	260	108	42	M16	110	90	38	12	37	8	160	22	207	398	14,5	612	15	502	300	250	350	4-Ø18,5	5	181	181
HMA4 180M	2,4,6	279	70	347	355	256	241	304	121	48	M16	110	100	42	14	42,5	9	180	25	227	436	14,5	685	15	575	300	250	350	4-Ø18,5	5	181	181
HMA4 180L	4,6	279	70	347	355	256	279	342	121	48	M16	110	100	42	14	42,5	9	180	25	227	436	14,5	723	15	613	300	250	350	4-Ø18,5	5	181	181

# IE4 / B35

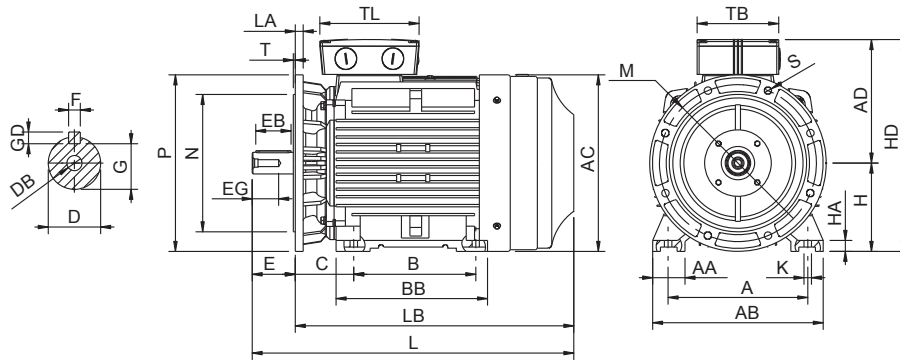

Motor type	Pole	A	AA	AB	AC	AD	B	BB	C	D	DB	E	EB	EG	F	G	GD	H	HA	HB	HD	K	L	LA	LB	M	N	P	S	T	TB	TL
------------	------	---	----	----	----	----	---	----	---	---	----	---	----	----	---	---	----	---	----	----	----	---	---	----	----	---	---	---	---	---	----	----

## Cast iron motors

HMC4 160M	2,4,6	254	312	314	253	210	260	108	42	M16	110	90	38	12	37	8	160	20	140	413	14,5	610	15	500	300	250	350	4-Ø18,5	5	160	200	64
HMC4 160L	2,4,6	254	312	314	253	254	304	108	42	M16	110	90	38	12	37	8	160	20	140	413	14,5	654	15	544	300	250	350	4-Ø18,5	5	160	200	64
HMC4 180M	2,4,6	279	348	355	269	241	311	121	48	M16	110	100	42	14	42,5	9	180	22	156	449	14,5	684	15	574	300	250	350	4-Ø18,5	5	160	200	68
HMC4 180L	4,6	279	348	355	269	279	349	121	48	M16	110	100	42	14	42,5	9	180	22	156	449	14,5	722	15	612	300	250	350	4-Ø18,5	5	160	200	68
HMC4 200L	2,4,6	318	384	397	296	305	369	133	55	M20	110	100	52	16	49	10	200	25	170	496	18,5	774	17	664	350	300	400	4-Ø18,5	5	200	250	70
HMC4 225S	4,6	356	426	445	319	286	361	149	60	M20	140	125	58	18	53	11	225	28	195	544	18,5	821	20	681	400	350	450	8-Ø18,5	5	200	250	79
HMC4 225M	2	356	426	445	319	311	386	149	55	M20	110	100	58	16	49	10	225	28	195	544	18,5	816	20	706	400	350	450	8-Ø18,5	5	200	250	79
HMC4 225M	4,6	356	426	445	319	311	386	149	60	M20	140	125	58	18	53	11	225	28	195	544	18,5	846	20	706	400	350	450	8-Ø18,5	5	200	250	79
HMC4 250M	2	406	484	484	370	349	445	168	60	M20	140	125	58	18	53	11	250	32	215	620	24	911	22	771	500	450	550	8-Ø18,5	5	211	271	97
HMC4 250M	4,6	406	484	484	370	349	445	168	65	M20	140	125	58	18	58	11	250	32	215	620	24	911	22	771	500	450	550	8-Ø18,5	5	211	271	97
HMC4 280S	2	457	542	546	400	368	485	190	65	M20	140	125	58	18	58	11	280	30	349	680	24	965	22	825	500	450	550	8-Ø18,5	5	211	271	85
HMC4 280S	4,6	457	542	546	400	368	485	190	75	M20	140	125	58	20	67,5	12	280	30	349	680	24	965	22	825	500	450	550	8-Ø18,5	5	211	271	85
HMC4 280M	2	457	542	546	400	419	536	190	65	M20	140	125	58	18	58	11	280	30	349	680	24	1016	22	876	500	450	550	8-Ø18,5	5	211	271	85
HMC4 280M	4,6	457	542	546	400	419	536	190	75	M20	140	125	58	20	67,5	12	280	30	349	680	24	1016	22	876	500	450	550	8-Ø18,5	5	211	271	85
HMC4 315S	2	508	628	620	502	406	570	216	65	M20	140	125	58	18	58	11	315	40	417	817	28	1201	22	1061	600	550	660	8-Ø24	6	300	258	120
HMC4 315S	4,6	508	628	620	502	406	570	216	80	M20	170	140	58	22	71	14	315	40	417	817	28	1231	22	1061	600	550	660	8-Ø24	6	300	258	120
HMC4 315M	2	508	628	620	502	457	680	216	65	M20	140	125	58	18	58	11	315	40	417	817	28	1311	22	1171	600	550	660	8-Ø24	6	300	258	120
HMC4 315M	4,6	508	628	620	502	457	680	216	80	M20	170	140	58	22	71	14	315	40	417	817	28	1341	22	1171	600	550	660	8-Ø24	6	300	258	120
HMC4 315L	2	508	628	620	502	508	680	216	65	M20	140	125	58	18	58	11	315	40	417	817	28	1311	22	1171	600	550	660	8-Ø24	6	300	258	120
HMC4 315L	4,6	508	628	620	502	508	680	216	80	M20	170	140	58	22	71	14	315	40	417	817	28	1341	22	1171	600	550	660	8-Ø24	6	300	258	120
HMC4 355M	2	610	726	698	590	560	750	254	75	M20	140	125	46	20	67,5	12	355	40	474	945	28	1501	25	1361	740	680	800	8-Ø24	6	340	300	116
HMC4 355M	4,6	610	726	698	590	560	750	254	95	M24	170	140	56	25	86	14	355	40	474	945	28	1531	25	1361	740	680	800	8-Ø24	6	340	300	116
HMC4 355L	2	610	726	698	590	630	750	254	75	M20	140	125	46	20	67,5	12	355	40	474	945	28	1501	25	1361	740	680	800	8-Ø24	6	340	300	116
HMC4 355L	4,6	610	726	698	590	630	750	254	95	M24	170	140	56	25	86	14	355	40	474	945	28	1531	25	1361	740	680	800	8-Ø24	6	340	300	116



# HOYER

EXCEEDING EXPECTATIONS

Hoyer Motors, IE4 Motors, October 2020