

Explosion Proof Motors  
Motor Manual

# Manual



**HOYER**  
MOTORS

## Ex Motor Manual

### OPERATION & MAINTENANCE INSTRUCTIONS FOR EN LOW VOLTAGE SQUIRREL-CAGE T.E. INDUCTION MOTORS

#### PROTECTION "EXPLOSION-PROOF – d" FRAME SIZES 71-315

Thank you for purchasing our electric motor. Before installation and use please read these instructions carefully.

#### General

These basic instructions are referring to catalogue EN/IEC low voltage squirrel-cage induction motors of totally enclosed design (index of protection IP55 or higher acc. to IEC 60034-5), of ribbed frame outer surface cooled with own fan situated under the fan cover (cooling method IC411 acc. to IEC 60034-6), in frame sizes 71-315.

Series, design and type can be determined from the type designation of the motor.

Type designation consists of a group of letters and numbers determined by internal manufacturer's standard.

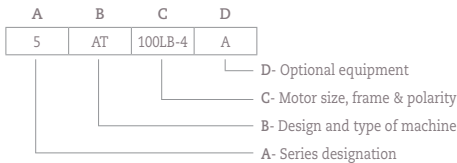

#### Series designation (mark A):

- 5 motor series design in aluminum alloy housing (design B3 – cast feet)
- 7 motor series design in cast iron housing (design B3 – mounted feet)

#### Motor type designation (mark B):

- AT explosion-proof motors: ex. protection: "flame proof – Ex d(e) I/II"
- ATA motors with different mechanical construction
- ABT shipboard use motors
- ATE motors with different electrical design than standard
- ATH motors with increased power output
- ATK motors with electromagnetic brake

- ATP multi-speed motors with constant torque at all speeds
- ATPV multi-speed motors for fans

#### Mark C describes as follows:

- 71 – 315 frame size
- S, M, L housing length
- A, B, C active part length in same length of housing
- 2,4, 6/4.. motor polarity

#### Optional mark or machine construction (mark D):

- A motors with winding heater
- G motors with feedback device
- K motors with connection cable
- T motors with thermal protection
- V force ventilated motors (separate fan)

All motors from this catalogue are made in their basic design in the index of protection IP55. This is the art of protection which protects persons against the contact with the parts under electrical tension ("live" parts), and the moving parts inside of enclosure. Further, it protects the electric device itself from the harmful down settling of dust and from the water jets from all directions. Index of protection is defined on the motor's nameplate and should be considered when installing the motor into the working position.

On request, there are also motors made to comply with other indexes of protection, usually IP56, IP65 and IP66.

#### Transportation and storage

The motors must be transported by means and in such a way which prevents the possible damage, i.e. they must be positioned exactly like they are situated in their basic and original transport packing. The storage in dry indoor areas far away from possible corrosion hazards is recommended. In case of longer storage time, it is necessary at least once per year to turn the rotor manually for one full circle. If more than 3 years have passed from the delivery time during which the motor was not put into motion, it is necessary to change the bearings, or if those are regreasing kind, follow the procedure described in the paragraph 6. Motor storage handling must be performed in a regular way using the lifting rings on motors or the pallet system.

## Setting into working position

Foot-mounted motors must be put on a hard ground adequately to their size and mounting requests stated in IEC 60034-7 and fixed with screws. Flange-mounted motors are fixed directly with screws on the counter flange of driven machine.

Before setting the motor into working position the protective cylindrical cover is to be removed from shaft. The motors must be situated in such way which assures the sufficient ventilation and heat transfer area. Minimum distance in mm, from fan cover or from suction/exhaust jalousie openings, to an obstacle must be at least equal to the rated motor frame size/shaft height figure.

The motors are intended for outdoor and indoor mounting for duty in ambient of moderate humidity, low corrosive aggressiveness, temperature range from -20 to +40°C and up to 1000 m height above the sea level, or for mounting indoors.

In case of reduced cooling condition at higher altitudes or higher environmental temperatures, motor power should be changed according to tables below:

Cooling air temperature °C	30	35	40	45	50	55	60
% rated power	100	100	100	96	91	86	80

Altitude above the sea level [m]	2000	3000	4000
% rated power at ambient temperature of 40°C	92 %	84%	78%
Rated power at ambient temp. in °C	32°C	24°C	16°C

Motors produced with protected windings for tropical working conditions bear the marking "TROPICALIZED".

Before every installation the motor must be checked for possible damages or possible irregular mounting circumstances which can influence the proper operation. During

assembly on transmission unit or driven machine, punching and applying of excessive force must be avoided, especially in direction of motor drive axis because this can cause bearing damage or permanent disturbance of safety gaps in motors protected with "explosion-proof enclosure - d". If needed, the data about permitted radial and axial forces acting on motor DE and depending upon the mounting arrangement can be requested from manufacturer. All fixing screws must be tightened with adequate torque in order to assure smooth work of motor itself, without vibrations, deformations or overstress. The screws must be secured from unfastening.

If non-elastic couplings are used, the proper coaxial alignment with DE shaft must be assured during assembly (acc. to the sketch) and at belt transmissions the magnitude of belt tension force and it's perpendicularity to the DE shaft must be considered.

Rotors are dynamically balanced with half-key acc. to ISO 8821, so that all elements which are directly mounted on DE motor shaft must be also dynamically balanced on the same way.

## Connection to the power supply network and safety/protection measures

Before connecting the motor to the power supply the special care must be taken about the following:

- that the motor data on nameplate corresponds to the power supply voltage and frequency
- that the terminals are connected according to appropriate connection diagram labeled inside of motor terminal box, or according to the nameplate data and the power supply itself (in case if motor starting via the Y/D switch is requested, the bridges from terminal plate must be removed!)
- that the protection of live parts is maintained according to local safety regulations. The earthing lead must be connected to specially marked place inside of ter-

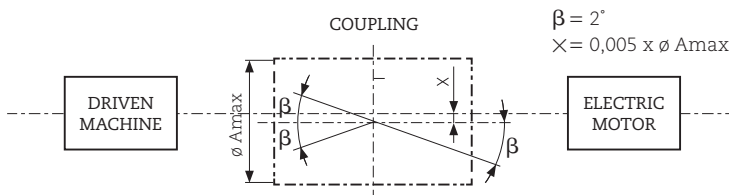

## Ex Motor Manual

minal box and the motor must be earthed also via the bolt situated outside on the frame. Earthing lead cross-section area must be greater than or equal to those one of phase lead. Outer earthing clappings are foreseen for earthing lead of minimum cross section area of 4mm<sup>2</sup> (frame sizes up to 180) or of 16mm<sup>2</sup> (frame sizes 200 to 315)

- all valid safety measures must be regarded acc. to actual protection system against the electric current shock
- that terminal box interior is free from dirt, connecting material particles or the like
- that all terminals on motor terminal plate are hard tightened. Max. Moments for tighten are: M4 – 2Nm, M5 – 3,2Nm, M6 – 5Nm, M8 – 10Nm i M10 – 20Nm
- that energy supply cable (and eventually cable(s) for auxiliary devices supply) is adequately sealed by the means of the motor terminal box cable glands
- that adequate protection against short-circuit and overload (fuses, bimetal relays, thermal protection or the like) is assured
- that motor connecting to the power supply is performed with the cable of adequate dimensions and heat resistance (for AT series motors there are special requests stated for cables defined in "Manufacturer's declaration")

On three-phase power supply with voltages 400V can be connected the motors with nameplate data D/Y 400/690V in winding connection delta (D) acc. to connection diagram labeled inside of terminal box.

On same power supply network, motors with nameplate data D/Y 230/400V in connection star (Y) can also be connected. Motors with those data can be connected also on three-phase network voltage 230V but they must be in winding connection delta (D). Generally, the motors are connected to the power supply network via the three-pole switch, three-pole motor protection circuit breaker or contactor.

In case of starting via the star-delta (Y/D) switch, the winding connection of motor for rated voltage must be delta (D). In this case the starting current amounts 1/3 of such current in direct connection as does the starting torque, and this must be considered, i.e. in such way only motors with no load can be started. Two-speed motors with series-parallel winding (tap wound –speed ratio 1:2) are started by means

of special switch. Net connecting of two and multi-speed motors is performed in accordance to the connection diagram labeled inside of motor terminal box with adequate protection against the short circuit and overload.

Generally, the three-phase motors manufactured by HOYER are designed acc. to requests of standard IEC 60038 and can work without problems under rated power and torque load with network voltage aberration of  $\pm 10\%$ , until the single-phase HOYER motors can work under such conditions with network voltage/frequency aberration of  $\pm 5\%$  /  $\pm 1\%$ . If the voltage aberration is greater, the motor cannot be loaded with rated torque but with the torque which must be corrected in proportion to voltage drop.

Drives where the motor is supplied via the static frequency converter (speed regulator), the recommendations from the standard IEC 60034-17 are applied, so considering these, the care must be taken when choosing the rotational speed regulator. For motor supply it is desirable to use the frequency converter (rotational speed regulator) equipped with output dU/dt filter in order to achieve higher motor winding longevity. For such supply it is useful to contact the motor manufacturer regarding the motor characteristics and regulation range.

If motor has built-in anti-condensation heaters, they are to be connected acc. to the attached connection instruction and energized during the motor is in standstill state.

### Rotation direction change and number of starts per hour

The motors of standard design have the clockwise direction of rotation viewed from the shaft DE, and they are connected acc. attached instructions. Change of rotation direction is usually performed by changing the terminal sequence of two supply net phases. At often changing of rotation direction, the special switch for reversing is to be used, taking care about the permissible reversions per hour for particular drive and load (if necessary, consult the manufacturer). The same is valid for permitted number of starts in order to not overload the motor.

Rotation direction change at single-phase motors is performed with connector exchange of main or of auxiliary phase. Before reversing the motor must be at standstill (on contrary, it will keep the same rotation direction).

## Maintenance

The motors are designed for the easy and simple maintenance. Properly installed and electrically / thermally protected they can work for years.

Periodically they need to be exterior cleaned and if they work in environment where impurities can close the ventilation openings on fan cover or fill the spaces between the cooling ribs, such impurities must be blown out with compressed air or swept-off with brush. Any aberration from motor ratings or irregular motor operation must be carefully inspected for possible cause (i.e. increased motor current, temperature increase over the permitted value for the declared insulation class, increased vibrations, peculiar noises, specific insulation smell presence, activated motor protection devices or the like). If this is caused by the motor, the repair work must be performed by the authorized and skilled personnel only.

For spare parts contact the manufacturer with exactly determined motor type mark and code number from motor nameplate (please note the ordering instruction attached).

Standard bearing assembly is with single row deep-groove ball bearings (ZZ or 2RS), with clearance C3 as listed in table below. The bearings are lubricated for life. Bearing change in case of breakdown, noise or at regular service intervals must be performed with adequate tools without applying of excessive force and punching.

If bearings with regreasing possibility are built-in, the intervals between regreasing are as shown in the diagram attached. During service repair such bearings are to be taken off from shaft in the proper way, washed well in gasoline, dried, put on the shaft in the proper way, regreased with adequate grease in such way that approx. 2/3 of bearing nest free space is filled with grease. Alternatively, the regreasing can be performed also during the motor is in operation, via regreasing nipples situated on bearing shields using the hand pump for consistent grease. Depending upon the motor size (mostly 132-280), at each regreasing approx. 20-40 grams of grease must be pressed-in. Recommended grease brands are SKF, SHELL ALVANIA G3, ESSO UNIREX N3, or all others lithium soap based with drip temperature of 180-200 °C and for use in environment temperature range from -20 °C to +150 °C.

IEC motor frame size	Series 5AT/7AT	
	DEEP GROOVE BALL BEARING Bearing type on DE/NDE	Oil seal type on DE/NDE
56	6201 – 2RS (C3)	A12 x 22 x 6
63	6202 – 2RS (C3)	A15 x 25 x 5
71	6203 – 2RS (C3)	A17 x 28 x 7
80	6204 – 2RS (C3)	A20 x 35 x 7
90	6205 – 2RS (C3)	A25 x 37 x 7
100	6206 – 2RS (C3)	A30 x 47 x 7
112	6306 – 2RS (C3)	A30 x 47 x 7
132	6208 – 2RSC3	A40 x 55 x 7
160	6309 – 2RSC3	A45 x 60 x 7
180	6310 – 2RSC3	A50 x 65 x 8
200	6312 – 2RSC3	A60 x 80 x 10
225	6313 – 2RSC3	A65 x 85 x 10
250	6314 – 2RSC3	A70 x 90 x 10
280	6316 – C3	A80 x 115 x 12
315	6319 – C3	A85 x 115 x 13

On request, in motors of frame sizes 132-315 also the single-row roller bearings can be built-in series NU.

Remarks :table is valid for all polarities of single and multi-speed motors and for all mounting arrangements acc. to IEC 60034-7 (EN60034-7)

- nominal bearing life under rated working conditions is minimal 40000 working hours for 4, 6 and 8-poles motors, and minimal 20000 working hours for 2-poles motors connected to 50Hz power supply network.

Bearing regreasing interval determining diagram:

## Ex Motor Manual

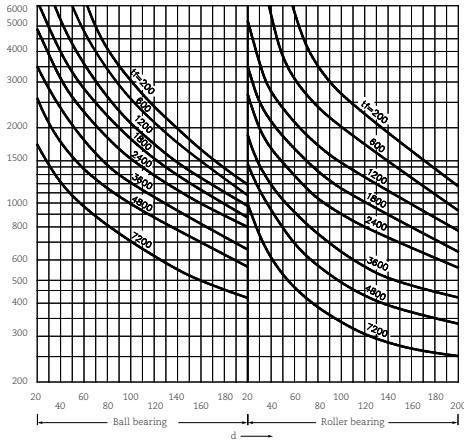

Example :

Deep-groove ball bearing with inner dia. of 40mm and rotational speed of 1500 rpm needs to be regreased approximately after every 6000 working hours (interpolation).

d – inner bearing diameter (mm)

n – rpm (min-1)

tf – regreasing interval (working hours)

During each disassembly of motor, we recommend installation of new shaft seals and seals securing the protection index of the motor.

## Basic designation of motors in the product range

Each motor in the product range is supplied with nameplate where basic information about the product and rated electrical data are stated.

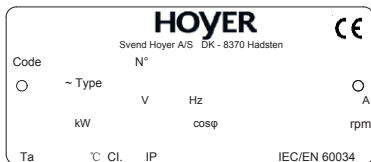

Basic name plate

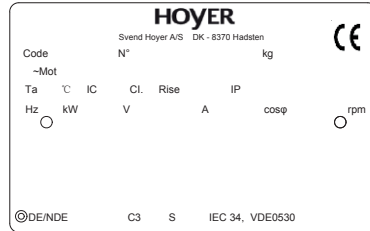

Basic name plate for multi voltage area or ones used for Exd(e) controlled via rotational speed regulator (duty regime S9)

There is following data stated on the nameplate:

Code: Motor number used for identification during the production process, and as a reference for ordering spare parts for the motor in the maintenance process.

N<sup>o</sup>: Factory motor number combined with the date of production

~ : Number of motor phases (1– single phase, 3 – three phase)

Type: Motor type designation mark according to the explanation from the introductory part of this instructions combined with mounting arrangement (B3, B5, B14...)

V, Hz : Voltage and frequency of the power supply for which the motor is built, and where motor generates rated characteristics when under rated loaded stated in kW column

A, min<sup>-1</sup>, cos φ: rated characteristics generated by the motor when under rated loaded stated

To : Environment temperature for which the motor is built, and at which it can be loaded with rated power.

Cl : Insulation system used in the motor (F– the highest allowed temperature 155°C, H-180°C)

IP : Index of protection achieved by housing and bearing shields design with regard to the harmful influence of water and dust.

S : Type of duty regime for which the motor is built (S1 – S10)

The last line of the name plate contains information on installed auxiliary equipment.

For single phase motors – information about installed run/start capacitors.



## Ex Motor Manual

Value of force  $F_g$  for belts is determined according to its cross section with keeping the deflection not smaller than  $f > 0,016a$  ( $a$  – axis distance), for belts specified in table 1.

Belt Cross Section	SPZ	SPA	SPB	SPC	Y	Z	A	B	C	D	E
$F_g$ [N]	25...27	45...50	75	125...140	13	24	40	70	120	240	360

If necessary, properly set the belt pretension until the specified depth of impression  $f$  is reached. If the drive belt is not properly tightened, the result will be an inadequate transmission of power and a premature failure of the drive belt. A too high pretension will additionally be the cause of bearing damages. When tightening the belt, make sure that the lateral alignment of the belts does not deviate by more than 1 degree

## Operation & maintenance extras regarding each of designs/series/type designations

### MOTORS OF SERIES/TYPED DESIGNATIONS 5 AND 7AT (ATP, ATPV, ABT, ABTP, ABTPV), EXPLOSION PROTECTED WITH TYPE OF PROTECTION “EXPLOSION-PROOF-d”

For these motor series, together with these instructions, the “manufacturer’s declaration” is also issued as a proof that control and testing were performed and that motors are manufactured according to the certified documentation:

- motors must be installed and used in accordance with adequate regulations for explosion protection regarding the dangerous zones classification, areas of use and explosive groups of inflammable materials or in accordance with motor nameplate and ex-protection nameplate data. Motors with Ex-protection “d” i “n” can be power supplied via static frequency converter in conditions according to IEC 60034-17. In such case motors must have built-in thermal-protection in stator winding. For these motors along with the “Manufacturer’s statement”, “Appendix to the Manufacturer’s statement” is also issued, defining regulation range and required torque/power reduction depending on the operating conditions. In case of uncertainties, contact the manufacturer.

- motors with Ex-protection by shielding “d” intended for use in mining are not suitable for hard operating conditions areas.

- Overload protection in the control box (on installations), should be adjusted according to the HRN IEC 60079-14 norm,

and for motors with Ex-protection increased safety additionally, in accordance with critical heating time until reaching the allowed over-temperature of the motor for certain temperature class stated in motor type designation marking and  $I_x/I_N$  rate stated on the motor name plate.

-all motors must be equipped with appropriate cable glands in accordance with requirements of corresponding norms. For cable gland with cylindrical threading, protection against unfastening is achieved by nut on the inside of the housing, (counter-nut), or appropriate filling (i.e. LOCTITE 243). Motors are shipped from the factory without the filling, and responsibility for securing the gland against unfastening, lays on authorized personnel when installing the motor.

– Cable entry are designed with Mxx x1,5 cable glands like in table. In case when are some differens it is on name plate or declaration specified.

IEC size	Series 5AT / 7AT	
	Number of glands x gland size	Diameter of connection cable M (mm)
71	1x M20x1,5	6 - 12
80	1x M20x1,5	6 - 12
90	1x M20x1,5	6 - 12
100	1x M25x1,5	13 - 18
112	1x M25x1,5	13 - 18
132	1x M32x1,5+ plug M32	18 - 25
160	1x M32x1,5+ plug M32	18 - 25
180	1x M40x1,5+ plug M40	22 - 32
200	2x M40x1,5	22 - 32
225	2x M50x1,5	29 - 38
250	2x M50x1,5	29 - 38
280	2x M50x1,5	29 - 38
315	2x M63x1,5	34 - 44

-On motors delivered with threaded holes for attaching cable glands and thread protecting closed plastic plugs manufacturer according to regulations, an authorized contractor is obliged to install certified cable glands into these holes or, if there are any extra holes, close them with certified plugs according to regulations. In addition while performing connecting; the motors have to be connected with isolated terminals.

In case of assembly and disassembly of motors, existing mechanical protection has to be provided (use of sealing agents on contact surfaces, coating of screw joints with fillers, grease fulfilments in bearings, greasing of shaft seals...)

### Specificities regarding the X-mark of CESI certificate

With regard to the specificities concerning the use limitations, installation and maintenance of Ex-motors form the production range and inability to list them all here, we ask kindly the user and the personnel authorized for installing of the equipment to study the Manufacturer's statement where all limitations for the motor are stated.

Repair of these motors must be conducted by manufacturer HOYER or listed authorized repair services. In no EU countries these are repairman in compliance with local regulations.

Without special written permission from the manufacturer any action that has or may have influence on anti-explosion protection of the motor (during warranty period or after) is absolutely liability of the ones carrying out the procedure, especially :

- When procedures are carried out on protective systems of Ex-protection "d" motors. During such procedures it's necessary to request instructions (and dimensions) from HOYER because air gaps are smaller than ones allowed by EN 60079-0,-1 norm.

- The supply cables of motors for the ambient temperature of + 60°C shall be suitable for an operating temperature equal or greater than 85°C, for ambient temperature +80°C supply cable shall be suitable for an operating temperature equal or greater than 105°C.

- The screws used for fastening of the parts of motor enclosure size 132, 160, 180 and 280 shall have a yield stress higher than 800 N/mm<sup>2</sup>.

- The screws used for fastening of the parts of motor enclosure size 200, 225 and 250 shall have a yield stress higher than 1200 N/mm<sup>2</sup> for the assembly with shield and 800 N/mm<sup>2</sup> for the assembly with terminal box.

- The motor provided with the cables permanently connected, shall have these cables protected against the risk of damage due to mechanical stresses. The end connections shall be made according to one of the types of protection indicated in the EN 60079-0 standards according to the installation rules in force in site of installation.

- Motor is built in compliance with IEC 60034-17, so it is capable to work with power supply from frequency converter (2p=2; 5 to 87 Hz and 2p=4, 6, 8; 5 to 100 Hz). According to

IEC 60034-11 for motor winding there are according to temperature class (T4) 3xPTC-130°C or (T3)150°C ± 5°C sensors. Characteristics of thermal sensors are in compliance with DIN 44081/44082. Speed regulation range is defined by data stated on motor name plate, and given torque reduction diagram defines or torque and power. Frequency converter used for this drive must be in compliance with IEC 60034-17 for protection of over voltage and from voltage gradient change. Protection from short-circuit of any kind (to phase, to earth) must be provided inside frequency converter device.

### Designation of motors with Ex-protection

Every motor with Ex-protection, along with basic nameplate according to paragraph 7. of this instructions, has on it's housing additional plate with information about type of anti-explosive protection.

### Motors with Ex-protection "EXPLOSION-PROOF- d"

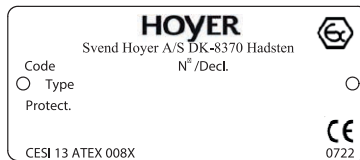

Nameplate for Ex d (e) motors with CESI certificate

There is following data stated on the nameplate:

Code: Motor number used for identification during the production process, and as a reference for ordering spare parts for the motor in the maintenance process.

N°: Factory motor number

Type: Type designation of the motor

Protection: Type of anti-explosion protection

## Ex Motor Manual

### Possible failures and interferences at work of squirrelcage induction motors and their remedying

FAILURE / INTERFERENCE SYMPTOMS	POSSIBLE CAUSE	HOW TO CURE / REMEDY
Motor cannot run up, no noise at all or the humming is strong	<ul style="list-style-type: none"> <li>-Supply interrupted, one of feeder lead broke, lines broke, for example one over the fuse</li> <li>-Stator winding circuit interrupted, disconnection in Y/D switch, motor protection fallen out</li> <li>-Damaged bearings</li> <li>-Improper connecting</li> <li>-Main or auxiliary phase interrupted</li> <li>-Damaged capacitor (motor runs up if pushed per hand)</li> <li>-Damaged centrifugal switch</li> <li>-Klixon off or damaged</li> </ul>	<ul style="list-style-type: none"> <li>-Check fuses, motor switch or contactor or protection circuit breaker...</li> <li>-Separate supply leads, check the winding on terminal plate terminals, check the elements of electrical protection</li> <li>-Change the bearings</li> <li>-Connect the motor acc. to appropriate instructions</li> <li>-Winding repair or change</li> <li>-Change capacitor</li> <li>-Centrifugal switch repair or change</li> <li>-Klixon on - or must be exchanged</li> </ul>
Motor cannot accelerate under load, or accelerate hardly, sudden drop of rotational speed under load	<ul style="list-style-type: none"> <li>-Load torque too high (overload)</li> <li>-Motor intended for D connection, but Y connected</li> <li>-Supply voltage too low</li> <li>-Faulty feeder lead</li> <li>-Rotor squirrel stick or short-circuit ring interrupted</li> </ul>	<ul style="list-style-type: none"> <li>-Must be in accordance with motor frame size</li> <li>-Apply the regular way of motor connecting</li> <li>-Stabilize the supply voltage</li> <li>-Check the supply rightness</li> <li>-Change the rotor</li> </ul>
At start, fuse blows or protection circuit breaker switches-off	<ul style="list-style-type: none"> <li>-Feeder leads from motor switch to motor are in short circuit</li> <li>-Two phases of stator winding are in short circuit or earth connected</li> <li>-Wrongly chosen/adjusted motor protection</li> </ul>	<ul style="list-style-type: none"> <li>-Separate and insulate the leads</li> <li>-Separate the motor from supply probably it is necessary to be rewound</li> <li>-Choose/adjust motor protection properly</li> </ul>
Motor warming in operation is high scraping noises , motor protection is switching-off after some time	<ul style="list-style-type: none"> <li>-Motor overload (at single phase motors klixon is witching-off)</li> <li>-Too high or too low supply voltage</li> <li>-Too high motor switching-on intensity</li> <li>-Motor work on single phase</li> <li>-Rotor scraps on to stator</li> </ul>	<ul style="list-style-type: none"> <li>-Measure the motor current. If it is far too high in comparison to the rated one, cure the overload cause</li> <li>-Stabilize the supply voltage</li> <li>-Lower the switching-on intensity</li> <li>-Check supply leads</li> <li>-Rotor or motor need to be repaired</li> </ul>
Motor warming is high even under no load, pulls high current, humms, (1ph motors - thermal protection is switching-off)	<ul style="list-style-type: none"> <li>-Wrong stator winding connection</li> <li>-Supply voltage to high</li> <li>-Insufficient cooling</li> <li>-Short circuit between winding coils or motor mass</li> </ul>	<ul style="list-style-type: none"> <li>-Connect motor properly acc. to nameplate data and appropriate instructions</li> <li>-Stabilize the supply voltage</li> <li>-Assure undisturbed air flow to and around the motor</li> <li>-Change of winding</li> </ul>
Motor in operation causes increased and abnormal noise	<ul style="list-style-type: none"> <li>-Electrical reasons</li> <li>-Bearing damage</li> <li>-Damage in gearbox mounted on</li> <li>-Rotor unbalanced</li> <li>-Insufficient fixing on the ground or flange</li> <li>-Friction disc scraps</li> </ul>	<ul style="list-style-type: none"> <li>-Consult the manufacturer</li> <li>-Change the bearings</li> <li>-Check the gearbox</li> <li>-Rebalance dynamically the rotor of drive</li> <li>-Tighten the appropriate screws with adequate torque</li> <li>-Check the air gap or wear-off of friction disc lining</li> </ul>

## Working life of motors by HOYER

- under normal conditions of use foreseen by these operation & maintenance instructions and with regular maintenance the motor working life is more longer
- The manufacturer assures the availability of spare parts in the period of time up to 7 years including also the period of time under which the warranty is valid. Service at manufacturer is possible also for products older than 7 years with special contracting conditions
- All production documentation is available 10 years after the production cease date of the particular type

## Warrenty claims

Breakdowns in duty or damages detected on products prior to the expiry of warranty need to be, if they are induced with material faults or bad manufacturing quality, reported to manufacturer **HOYER** indicating the following data :

- exact motor nameplate data (type description and code number)
- how was the motor connected while in operation
- characteristics of the drive
- how deficiency/fault appeared (the appearance art of the fault)

Breakdowns in duty or damages due to inadequate use and careless transportation / storage / connecting, **are not considered as justified warranty claims** during period of warranty. The same is valid also if the product, before it's return to the manufacturer, was disassembled during period of warranty.

## Declaration of warranty

Quality managing system introduced in **HOYER** is certified in accordance to the requests stated in **ISO 9001** standard. Based on this, the regular work of our products is assured with rigorous process control and final inspection before dispatch to the customer, on ground of which the warranty is issued. If despite of this, irregular operation or disturbance in duty, caused with bad manufacturing quality or material fault appears, we oblige ourselves to cover all repair/correction costs and that guaranteed regularity of product will be established again.

Warranty is valid **12 months** from the day of product sale/ takeover, what is testified with salesman's stamp, datum and signature on warranty leaflet and attached invoice.

The customer is obliged to follow the operation and maintenance instructions attached to every motor which bears the **HOYER** manufacturer's logo.

We cover the transportation costs regarding the necessary warranty service repair, on basis of properly issued invoice according to valid railway or postal charges from outgoing railway or postal station.

If, during the period of warranty, repair work will consume more than 10 days counting from the day of reclamation report/motor return, the date of warranty expiry will be postponed for the same number of days the repair work actually took.

If the repair work is not executed during 45 days counting from the day of report/return, or it is impossible to remedy the fault, we will exchange the product with a new one. The **faults that did not occur due to material faults or bad manufacturing quality are not considered** as manufacturer's faults, and therefore induced costs of their repair/correction are liability of the buyer of product according to valid **HOYER** manufacturer's pricelist.

The repairs during and beyond from warranty period are performed by **HOYER**.

## Ordering guideline

All above listed standard spare parts differ between each other depending upon the type of motor, frame size, series and possible peculiarities.

To allow us to pinpoint them exactly, please assure when ordering, that the following data are available:

- name and position number of the spare part according to the above list and exploded view
- type designation of the motor
- motor code number

} from the motor name plate

Example:

Pos. 5 Fan  
5.5AZS 71B-2/T3 ; B3  
A500201

## Ex Motor Manual

### EN/IEC

Three phase cage induction explosion-proof motors  
shielding “d”

type designation

AT, ATP, ATPV, ABT, ABTP, ABTPV

sizes

71 – 112 (series 5)

132 – 315 (series 7)

Three phase cage induction explosion-proof motors  
shielding “d” protection EN/IEC sizes:

71-112 ( 5AT series), 132-315 ( 7AT series) :

Poz/Pos	Name
1	Wound stator
2	Rotor (half-key balanced)
3	DE shield – B3, B5, B14
4	NDE shield
5	Fan
6	Fan cover
7	Bushing insulators
8	Terminal box O-seal
9	Terminal box
10	Terminal box lid O-seal
11	Terminal box lid
12	Lid
13	Cable gland
13.1	Cable adapter
14	Plug
15	Bearing DE
15.1	Bearing NDE
16	Resilient preloading ring
17	Circlip
18	Shaft key
18.1	Shaft key NDE
20	Frame foot,right
21	Frame foot,left
22	Lifting ring
26	Fixing bolt

Three phase induction explosion-proof  
motors shielding "d" protection EN/IEC sizes:

71 - 112 (5AT series)

132 - 315 (7AT series)

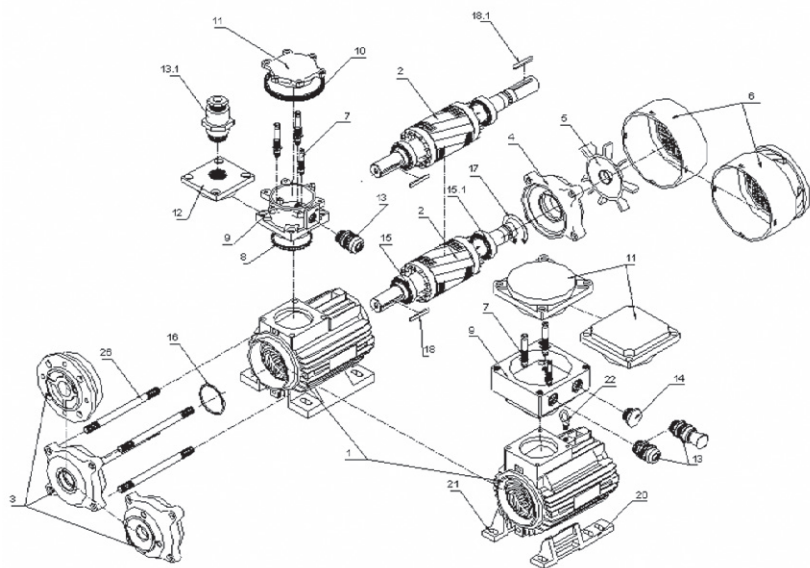





**HOYER**

EXCEEDING EXPECTATIONS

Hoyer Motors, Ex Motor Manual, November 2019