

OPERATION AND MAINTENANCE INSTRUCTIONS

DESMI vertical "in-line" centrifugal pump

NSL Compact Spacer

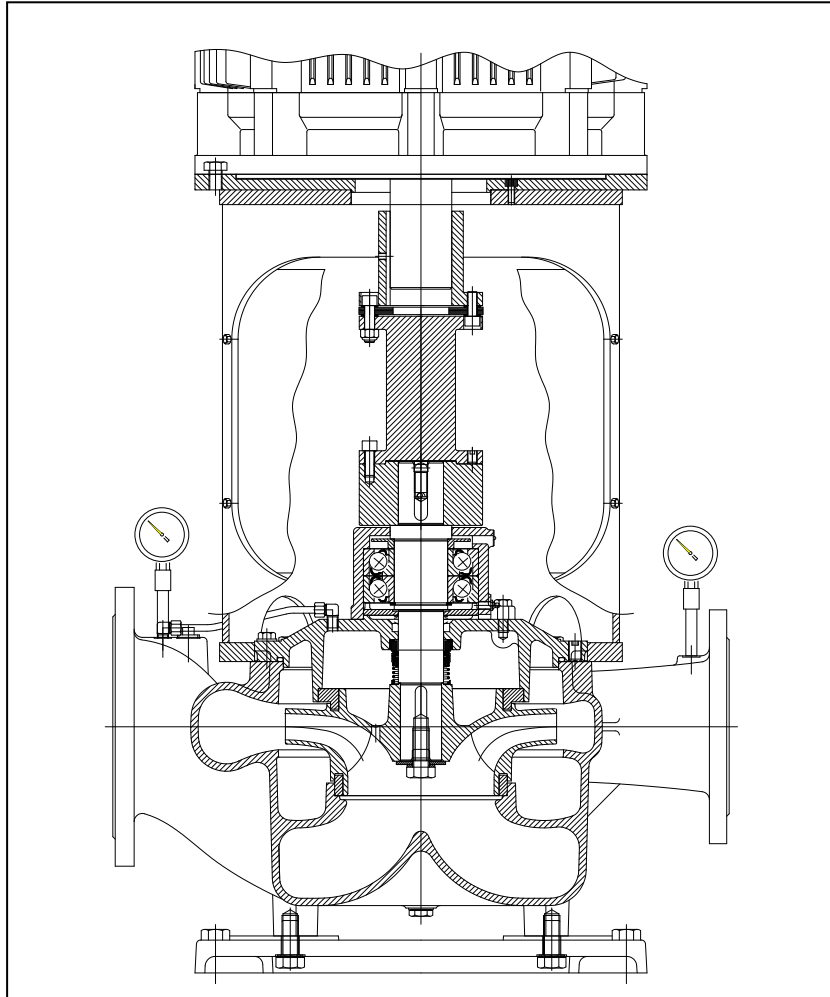

Manual: T1479	Language: English	Revision: H(02/22)
------------------	----------------------	-----------------------

Specialpumpe nr.

Table of Contents:

1. PRODUCT DESCRIPTION	1
1.1 DELIVERY	1
2. TECHNICAL DATA	1
2.1 EXPLANATION OF THE TYPE NUMBER	1
2.2 TECHNICAL DESCRIPTION	2
3.1 MOUNTING/FASTENING	5
3.2 WIRING	5
4. TRANSPORT/STORAGE	5
5. DISMANTLING.....	6
5.1 ACCESS TO IMPELLER.....	6
5.2 DISMANTLING SHAFT SEAL.....	6
5.3 DISMANTLING SEAT.....	6
5.4 DISMANTLING BEARING.....	7
5.5 INSPECTION	7
6. ASSEMBLING.....	7
6.1 FITTING SEALING RINGS	7
6.2 FITTING BEARING	7
6.3 FITTING WATER DEFLECTOR.....	7
6.4 FITTING SHAFT SEAL	7
6.5 FITTING IMPELLER	8
6.6 FITTING SHAFT SEAL COVER	8
6.7 FITTING COUPLING	8
6.8 SHAFT	9
7. FROST PROTECTION	9
8. DISMANTLING.....	9
9. START-UP.....	9
9.1 START-UP.....	10
10. SYSTEM BALANCING.....	10
11. INSPECTION AND MAINTENANCE	11
11.1 DRAINING THE PUMP	12
11.2 BEARING	12
12. REPAIRS	13
12.1 ORDERING SPARE PARTS	13
13. OPERATING DATA	13
14. EU & UK DECLARATION OF CONFORMITY.....	15
15. INFORMATION RELEVANT FOR DISASSEMBLY OR DISPOSAL AT END-OF-LIFE.....	15
16. ASSEMBLY DRAWING Ø215/265	16
17. SPARE PARTS LIST Ø215/265 SEE Ø330/415 PUMP ON THE NEXT PAGES.....	16

18. ASSEMBLY DRAWING Ø330/415 WITH LIGHT BEARING HOUSING	17
19. SPARE PARTS LIST Ø330/415 WITH LIGHT BEARING HOUSING	17
20. ASSEMBLY DRAWING Ø330/415 WITH HEAVY BEARING HOUSING	18
21. SPARE PARTS LIST Ø330/415 WITH HEAVY BEARING HOUSING	18
22. DIMENSIONAL SKETCH Ø215/265	19
23. DIMENSIONAL SKETCH Ø330/415	20

1. PRODUCT DESCRIPTION

These operation and maintenance instructions apply to the DESMI NSL Compact Spacer pump.

The pump is a single-stage vertical "in-line" centrifugal pump (i.e. horizontal inlet and outlet on the same line) equipped with stainless steel shaft, mechanical shaft seal, and closed impeller.

The pump is suitable for the pumping of liquids with temperatures up to 80°C. With special shaft seal up to 120°C. Max. working pressure and number of revolutions are indicated under Operating Data.

The pump is particularly suitable for the pumping of water in connection with cooling systems, cooling of diesel engines, as bilge pumps, ballast pumps, fire pumps, brine pumps, pumps for irrigation, fish farms, water works, district heating, salvage corps, army and navy, etc.

The descriptions in the operation and maintenance instructions are divided into two parts covering the groups **ø215/265** and **ø330/415**, as the designs of these two groups are different. The numbers refer to the standard impeller diameter of the pump. E.g.:

ø215/265: Pumps with ø215 or ø265 impellers:

The back of the impeller is equipped with relief blades to reduce the load on the bearings. The line through inlet and outlet is flush with the centre line of the shaft.

ø330/415: Pumps with ø330 and ø415 impellers:

The back and the front of the impeller are equipped with sealing rings and relief holes to reduce the load on the bearings. The pump inlet and outlet are tangential i.e. the line through inlet and outlet is offset in relation to the centre line of the shaft.

1.1 DELIVERY

- Check on delivery that the shipment is complete and undamaged.
- Defects and damages, if any, to be reported to the carrier and the supplier immediately in order that a claim can be advanced.

2. TECHNICAL DATA

The pumps are manufactured in various material combinations which appear from the type number on the name plate. See below.

2.1 EXPLANATION OF THE TYPE NUMBER

All the NSL pumps are provided with a name plate. The type number indicated on the name plate is built up as follows:

NSLXXX-YYY-MR-Z

XXX: Pressure branch diameter, YYY: Standard impeller diameter

M: The material combination of the pump.

R: The assembly combination of the pump.

Z: Other variants

M may be the following:

- A: Casing and shaft seal cover : Cast iron + cast iron alloy. Impeller and sealing rings: Bronze
- B: Casing and shaft seal cover : Cast iron + cast iron alloy. Impeller and sealing rings: Stainless.
- C: All cast iron
- D: Casing and shaft seal cover: Bronze or NiAlBz. Impeller and sealing rings: NiAlBz or Stainless Steel.
- E: Special materials
- U: Nonmagnetic material

The pumps can be delivered in other material combinations according to agreement with the supplier.

R may be the following:

- 02: Monobloc, with bearing in the pump
- 12: Monobloc, without bearing in the pump
- 13: Spacer, light bearing housing
- 14: Spacer, heavy bearing housing
- 15: Spacer, heavy bearing housing and heavy motor bracket (special motor bracket)
- 16: Compact spacer

Z may be the following:

- i : PN16 flanges
- j : PN25 flanges
- k : Special flange
- l : Other shaft seal
- m : BS flanges
- n : ANSI flanges
- o : Shockproof design
- p : Other design
- q : JIS flanges

Any use of the pump is to be evaluated on the basis of the materials used in the pump. In case of doubt, contact the supplier.

Pumps in material combinations A and C are primarily used for fresh water.

Pumps in material combination D and E are primarily used for seawater.

If the pumps are designed for special purposes the following is to be indicated:

Pump No. :
Pump type :
Application :
Comment :

2.2 TECHNICAL DESCRIPTION

The noise level indicated is the airborne noise including the motor. The noise depends on the motor type supplied, as the noise from the pump can be calculated as the noise level of the motor + 2dB(A). The noise level is for pumps with electric motors.

The capacity of the pump appears from the name plate on the pump. If the pump has been delivered without motor, the pump capacity is to be indicated on the plate when mounting the motor.

The permissible loads on the flanges appear from the following table. The values apply to standard pumps in bronze (Rg5) and cast iron (GG20). As to pumps in SG iron (GGG40) the values are to be increased by factor 1.5.

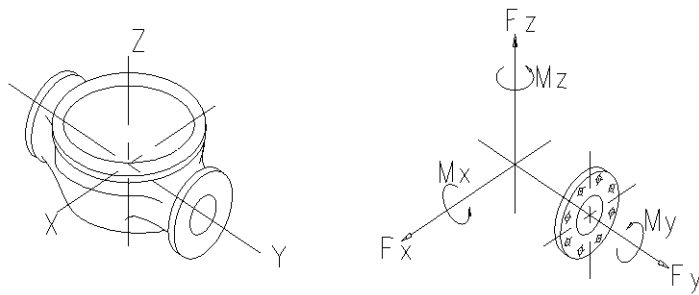

Pump	Fy N	Fz N	Fx N	ΣF	My Nm	Mz Nm	Mx Nm	ΣMt
NSL80-215 NSL80-265 NSL80-330	800	950	850	1500	550	350	400	750
NSL100-215 NSL100-265 NSL100-330 NSL100-415	1000	1250	1150	2000	650	400	500	900
NSL125-215 NSL125-265 NSL125-330 NSL125-415	1250	1600	1430	2500	830	520	650	1160
NSL150-215 NSL150-265 NSL150-330 NSL150-415	1500	1900	1700	2950	1000	650	800	1400
NSL200-265 NSL200-330 NSL200-415	2000	2520	2260	3920	1330	860	1060	1860
NSL250-265 NSL250-330 NSL250-415	2500	3150	2820	4900	1770	1140	1400	2470
NSL300-415	2500	3750	3350	5860	2750	1900	2200	4000

In connection with the permissible loads on the flanges the following is to be observed:

$$\left(\frac{\sum F_{calc}}{\sum F} \right)^2 + \left(\frac{\sum M_{calc}}{\sum M_t} \right)^2 < 2$$

where index "calc" is the values calculated by the user.

At the same time none of the forces or moments may exceed the indicated figure multiplied by 1.4.

3. INSTALLATION

3.1 MOUNTING/FASTENING

The pump should be mounted and fastened on a solid base plate with a flat and horizontal surface to avoid distortion.

The max. permissible loads on the flanges stated in paragraph 2.2 are to be observed.



At installations pumping hot or very cold liquids, the operator must be aware that it is dangerous to touch the pump surface and, consequently, he must take the necessary safety measures.

3.2 WIRING



Wiring to be carried out by authorised skilled workmen according to the rules and regulations in force.

4. TRANSPORT/STORAGE

The weights of the pumps in A and D combination (without motor) are stated in the following table, and the pumps are to be lifted as shown below. The D12-combination is as standard only available in ø330/415.

Pump	Weight in kg A16 / D16 comb. incl. base plate	Pump	Weight in kg A16 / D16 comb. incl. base plate
NSL80-215	176 / 191	NSL150-215	217 / 241
NSL80-265	184 / 201	NSL150-265	221 / 246
NSL80-330	276 / 281	NSL150-330	369 / 359
NSL100-215	187 / 204	NSL150-415	459 / 479
NSL100-265	185 / 202	NSL200-265	256 / 289
NSL100-330	291 / 297	NSL200-330	439 / 424
NSL100-415	379 / 399	NSL200-415	554 / 574
NSL125-215	198 / 213	NSL250-265	335 / 375
NSL125-265	203 / 224	NSL250-330	519 / 509
NSL125-330	306 / 312	NSL250-415	634 / 639
NSL125-415	414 / 434	NSL300-415	734 / 734

The pump is to be stored in a dry area.

Before shipment the pump is to be fastened securely on pallets or the like.

The pump is to be lifted in the following way:

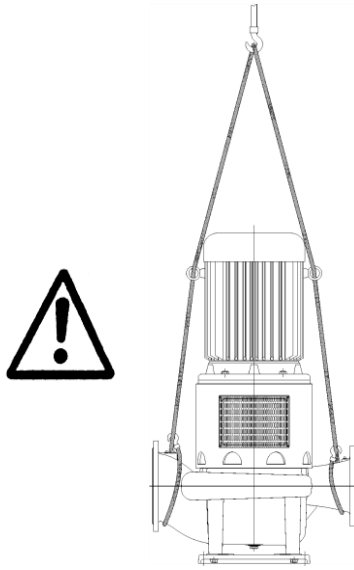

The lifting straps must not bear against sharp edges and corners

5. DISMANTLING

5.1 ACCESS TO IMPELLER

The numbers in brackets refer to the position numbers on the assembly drawing.

Dismantle guard (69). Dismantle copper pipe (58). Dismantle Allen screws (76) and (80). Remove coupling discs (74) between spacer and coupling part motor (71). Dismantle Allen screws (77). Loosen spacer (72) from coupling part pump (70) by means of the pointed screws (36). Now remove spacer. If additional space is required for dismantling, loosen coupling part pump (70) and coupling part motor (71) at pointed screws (73) and pull off. A gentle heating of the pump and motor coupling parts may facilitate the dismantling.

Remove the screws (22) that keep the shaft seal cover (18) to the pump casing (1). Loosen shaft seal cover (18) from pump casing by means of the pointed screws (86) in the shaft seal cover. The shaft seal cover with shaft and impeller can now be lifted up allowing inspection of the impeller.

5.2 DISMANTLING SHAFT SEAL

ø215/265

Remove nut (6). Pull off the impeller (5) and remove sunk key (9). Remove Allen screws (19), which hold the bearing cover (15) to the shaft seal cover, pull shaft seal cover and bearing cover apart, by which shaft seal (10) and water deflector (11) are pulled off the shaft.

ø330/415

Remove set screw (6). Pull off the impeller (5) and remove sunk key (9). Remove set screws (19), which hold the bearing cover (15) to the shaft seal cover, pull shaft seal cover and bearing cover apart, by which the shaft seal (10) is pulled off the shaft.

5.3 DISMANTLING SEAT

Press out the seat from behind the shaft seal cover (18).

5.4 DISMANTLING BEARING

Before dismantling bearing, remove ring lock (12). Pull shaft with coupling out of the bearing cover and press out the bearing.

5.5 INSPECTION

When the pump has been dismantled, check the following parts for wear and damage:

- Sealing ring/impeller: Max. clearance 0.4-0.5 mm measured in radius.
- Shaft seal/shaft seal cover: Check the seat for flatness and cracks.
Check the rubber parts for elasticity.
- Bearings: Replace in case of wear and noise.

6. ASSEMBLING

6.1 FITTING SEALING RINGS

When fitted, the sealing ring (4) has to bear against the shoulder of the pump casing.

ø330/415

When fitted the sealing ring (27) has to bear against the shoulder of the shaft seal cover (20).

6.2 FITTING BEARING

Place the support disc (14) (grease valve ring in ø330/415 with angular ball bearings) in the bearing cover and press the bearing into place in the bearing cover. Lead the shaft through the bearing cover, support disc and bearing, and press the bearing into place up against the support disc. Fit ring lock (12).

ø330/415

Fit cover under bearing (26).

6.3 FITTING WATER DEFLECTOR

ø215/265

Assemble bearing cover and shaft seal cover. Lead the water deflector (11) over the shaft until it touches the shaft seal cover and then further 1-1.5 mm into the shaft seal cover. Do not fasten bearing cover and electric motor until motor and coupling have been mounted and the shaft can rotate freely without noise.

ø330/415

Lead the water deflector (11) over the shaft until it touches the cover under bearing (26) and then further 1-1.5 mm towards the cover under bearing. Assemble bearing cover and shaft seal cover. Do not fasten bearing cover and electric motor until motor and coupling have been mounted and the shaft can rotate freely without noise.

6.4 FITTING SHAFT SEAL

Pay attention to the rubber type of which the shaft seal bellows has been made. Standard is NITRILE, however EPDM may also be used. EPDM will be damaged by mineral grease. For EPDM use soft soap or silicone grease. Before fitting the seat, clean the recess in the shaft seal cover. Dip the outer rubber

ring of the seat into soapy water or apply silicone grease. Now press the seat into place with the fingers and check that all parts are correctly imbedded.

If it is necessary to use tools for assembling, then protect the sliding surface of the seat to prevent it from being scratched or cut. Lubricate the inner surface of the slide ring rubber bellows with soapy water and push it over the shaft. The use of a conical fitting bush as shown on the assembly drawing is recommended to avoid that the rubber bellows is cut.

Push the slide ring over the shaft with the hand. If the rubber bellows is tight, use a fitting tool and take care that the slide ring is not damaged. If the carbon ring is not fixed, it is important to check that it is fitted correctly, i.e. the chamfered/lapped side is to face the seat. The carbon ring can be held by a little grease.

When using soapy water on the shaft, the bellows will settle and seat in about 15 minutes, and until then tightness should not be expected. After start, check by viewing the leak hole in bearing cover/shaft seal cover that there are no leaks.

6.5 FITTING IMPELLER

Fit the sunk key in the shaft and lead the impeller towards the shoulder of the shaft. Take care that the ring at the end of the shaft seal spring locates in the recess of the impeller. Secure the impeller with washers (7 and 8) and a nut ($\varnothing 215/265$) or a set screw ($\varnothing 330/415$). Secure set screw (6) or nut (6) with a removable screw locking agent, e.g. Loctite 243 or Omnifit 40M. Tighten according to below table.

6.6 FITTING SHAFT SEAL COVER

Place the O-ring (21) between pump casing and shaft seal cover in the O-ring groove and hold it with a little grease. However, check the material of the O-ring first. As standard the material is NITRILE, but it may be EPDM which will be damaged by mineral grease. Use soft soap or silicone grease for EPDM. Fit and fasten shaft seal cover or motor bracket, mounted with the electric motor, in the pump casing. Screw the pointed screws (86) back into the shaft seal cover before tightening. Tighten the screws in the shaft seal cover according to below table. Fit copper pipe (58).

6.7 FITTING COUPLING

Fit sunk key (16) and motor shaft sunk key. Lead coupling part pump (70) against the shoulder of the shaft (17) and tighten by means of pointed screw (73). Mount coupling part motor (71). Do not tighten the pointed screw (73) into the coupling part motor until the remaining parts of the coupling have been mounted and tightened. Mount spacer (72) by means of Allen screws (77). Secure the screws with a removable screw locking agent.

Mount coupling discs (74) and washer (78) between spacer and coupling part motor by means of Allen screws (76), pinch nuts (79) and Allen screws (80). Secure screws with a removable screw locking agent. Turn the shaft a couple of times while tightening each screw slightly until coupling discs and coupling part motor have come into place. Now tighten Allen screws and pointed screw (73) in coupling part motor.

Check radial runout on the flanges, where the coupling plates are mounted, by means of a measuring gauge fixed to the motor bracket - see below drawing. After tightening-up the Allen screws (76 and 80) check that the radial runout does not exceed 0.1 mm. A larger runout may result in pump vibrations, increased bearing load and/or the impeller getting into contact with the pump sealing ring(s).

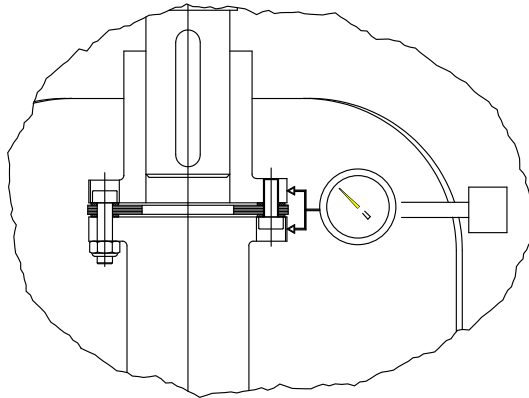

Tighten Allen screws in the coupling according to below table.

Screw dimension	Moment in Nm
M8	8
M10	15
M12	27
M16	65
M20	127

6.8 SHAFT

When the pump has been assembled, check that the shaft rotates freely and without noise.

7. FROST PROTECTION

Pumps which are not in operation during frost periods are to be drained to avoid frost damage. Remove the plug (3) at the bottom to empty the pump. Alternatively, it is possible to use anti-freeze liquids in normal constructions.

8. DISMANTLING

Before dismantling the pump make sure that it has stopped. Empty the pump of liquid before it is dismantled from the piping system. If the pump has been pumping dangerous liquids you are to be aware of this and take the necessary safety measures.



If the pump has been pumping hot liquids, take great care that it is drained before it is removed from the piping system.

9. START-UP

A centrifugal pump will not function until it has been filled with liquid between the foot valve and somewhat above the impeller of the pump.



The liquid also serves as coolant for the shaft seal. In order to protect the shaft seal the pump must not run dry.

ATTENTION

For safety reasons the pump is only allowed to operate against closed discharge valve for a short time (max. 5 minutes and at a max. temperature of 80°C for standard pumps). Otherwise there is a risk of damage to the pump and, at worst, of a steam explosion. If the pump is not monitored, the installation of a safety device is recommended.

9.1 START-UP

Before starting the pump check that:

- the shaft rotates freely without jarring sounds.
- the pump casing and the suction line are filled with liquid.

Start the pump for a moment to check the direction of rotation. If the direction is correct (i.e. in the direction of the arrow) the pump may be started.

10. SYSTEM BALANCING

It is often difficult to calculate a manometric delivery head in advance. It is, however, decisively important to the quantity of liquid delivered.

A considerably smaller delivery head than expected will increase the quantity of liquid delivered, causing increased power consumption and perhaps cavitation in pump and piping. In the pump the impeller may show signs of heavy erosion caused by cavitation (corrosion) which may at times render an impeller unfit for use in a very short time. Not unusually do similar erosions occur in pipe bends and valves elsewhere in the piping system.

Therefore, after start-up, it is necessary to check either the quantity of liquid delivered or the power consumption of the pump e.g. by measuring the current intensity of the connected motor. Together with a reading of the differential pressure the quantity of water delivered can be determined against the characteristics of the pump.

Should the pump not function as intended, please proceed according to the fault-finding list. Bear in mind, though, that the pump was carefully checked and tested at the factory and that the majority of faults stem from the piping system .

FAULT	CAUSE	REMEDY
The pump has no or too low capacity	<ol style="list-style-type: none"> 1. Wrong direction of rotation 2. Piping system choked 3. The pump is choked 4. Suction line leaks Pump takes air 5. Suction lift too high 6. Pump and piping system wrongly dimensioned 	Change direction of rotation to clockwise when viewed from shaft end (the direction of the arrow) Clean or replace Clean the pump Find the leakage, repair the fault, non-return valve not submerged Check data sheet Q/H curve and NPSH or contact DESMI As 5
The pump uses too much power	<ol style="list-style-type: none"> 1. Counter-pressure too low 2. The liquid is heavier than water 3. Foreign body in pump 4. Electric motor is running on 2 phases 	Insert orifice plate or check valve/Contact DESMI Contact DESMI Dismantle the pump, remove the cause Check fuses, cable connection, and cable
The pump makes noise	<ol style="list-style-type: none"> 1. Cavitation in pump 	Suction lift too high/ Suction line wrongly dimensioned/Liquid temperature too high

11. INSPECTION AND MAINTENANCE

Inspect the shaft seal for leaks at regular intervals.

- Before inspection of a pump without guard check that the pump cannot be started unintentionally.
- The system is to be without pressure and drained of liquid.
- The repairman must be familiar with the type of liquid which has been pumped as well as the safety measures he is to take when handling the liquid.

The drain hole at the mechanical shaft seal must be inspected regularly (see drawing example below). Clean the drain hole as needed. If the drain hole clogs up, leaking liquid and/or vapors from the shaft seal can be forced up into the bearing unit, which can result in a much shorter bearing life than normal.

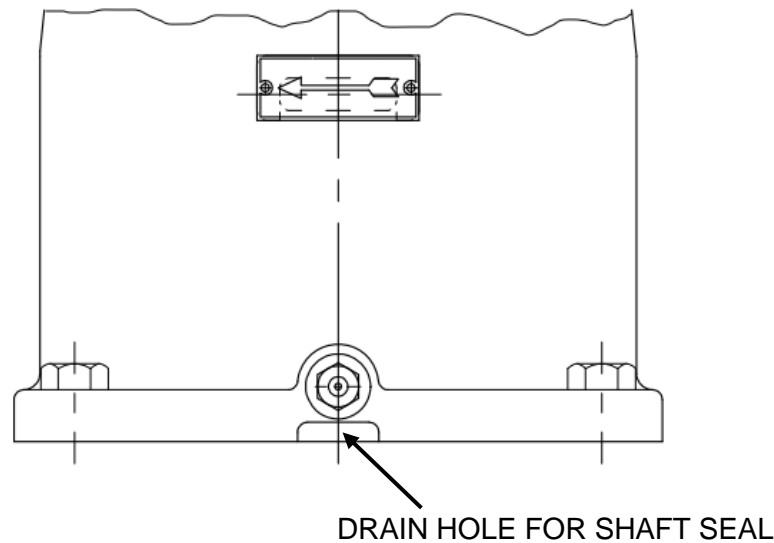

11.1 DRAINING THE PUMP

When the piping system has been drained, note that there is still liquid in the pump. Remove the liquid by dismantling the pipe plug (3) at the bottom of the pump.

11.2 BEARING

ø215/265

The bearing in the 02-combination is dimensioned for a nominal life of 25,000 working hours. The bearing is lubricated for life and requires no attention but is to be replaced in case of noise or bearing wear.

ø330/415

The bearing is dimensioned for a nominal life of 100,000 working hours and is to be relubricated according to the below table. The bearing is to be replaced in case of noise or bearing wear.

Light bearing housing ø330/415 (single-row ball bearing in NSL80-330, 100-330, 125-330, 100-415 and 125-415)

The bearing is to be re-lubricated through the lubricator nipple (84) in the bearing cover (15). In connection with replacement, the bearings are to be mounted with the RS - sealing facing downwards, fill the bearing itself with grease and place a grease bead on the bearing towards the shaft in a quantity corresponding to the table below.

Heavy bearing housing ø330/415 (two angular ball bearings in pumps not mentioned above)

The bearings are to be re-lubricated through the lubricator nipple (84) in the bearing cover (15). Fill the bearings with grease and place a grease bead on the bearing towards the shaft in a quantity corresponding to the table below.

Pump	Assembly	Interval	Quantity
NSL80-330 NSL100-330 NSL125-330 NSL100-415 NSL125-415	Light bearing housing	4500 hours	30 g

NSL150-330 NSL200-330 NSL250-330 NSL150-415	Heavy bearing housing	4500 hours	40 g
NSL200-415 NSL250-415 NSL300-415	Heavy bearing housing	4500 hours	50 g
NSL200-525 NSL300-525	Heavy bearing housing	4500 hours	80 g

If the pump liquid temperature is below 80 °C the following types of grease are recommended:

ESSO	Beacon 2
BP	Energrease EP grease 2
Shell	Alvania grease 2
Mobil	Mobil lux grease EP 2
Castrol	Spherol AP 2
Texaco	Multifak EP 2
Q8	Rembrandt EP 2 eller Rubens
Statoil	Statoil Uniway u2

If the pump liquid temperature is above 80 °C, high-temperature grease is recommended, e.g. SKF LGH P2/0.4.

DESMI use SKF LGHP2 as standard.

Note that relubrication can cause a (usually temporary) bearing temperature rise of up to approx. 20 °C - especially by mixing different types of grease and / or by overlubricating the bearing.

Grease used for relubrication must be compatible with the grease in the bearing unit.

12. REPAIRS

12.1 ORDERING SPARE PARTS

When ordering spare parts please always state pump type, serial No. (appears on the name plate of the pump), position No. on the assembly drawing and designation on the spare parts list.

13. OPERATING DATA

The following working pressures (pressure in piping incl. the pressure increase caused by the pump), number of revolutions and electric motors are allowed in standard pumps:

ø215 pumps are as standard available with motors up to frame size 225

ø265 pumps are as standard available with motors up to frame size 280

ø330 pumps are as standard available with motors up to frame size 315

ø415 pumps are as standard available with motors up to frame size 355

Pump	Max. working pressure [bar] Bronze / Cast iron	Max. working pressure [bar] SG-iron	Max. RPM	Pump	Max. working pressure [bar] Bronze / Cast iron	Max. working pressure [bar] SG-iron	Max. RPM
NSL80-215	16	32	1800 / 3600	NSL150-265	7	14	1800 / 1800
NSL80-265	14.5	29	1800 / 3600	NSL150-330	7 / 13	27	1800 / 1800
NSL80-330	15 / 15	32	1800 / 3600	NSL150-415	9 / 13	26	1800 / 1800
NSL100-215	13	26	1800 / 3600	NSL200-265	9	18	----- / 1800
NSL100-265	14.5	29	1800 / 3600	NSL200-330	7 / 13	26	1800 / 1800
NSL100-330	8 / 14	29	1800 / 1800	NSL200-415	9 / 13	26	1800 / 1800
NSL100-415	10 / 12.5	25	1800 / 1800	NSL250-265	10 / 10	20	---- / 1800
NSL125-215	10	20	1800 / 3600	NSL250-330	7 / 12	25	1800 / 1800
NSL125-265	14.5	29	1800 / 3600	NSL250-415	9 / 12	25	1800 / 1800
NSL125-330	7 / 12	25	1800	NSL300-415	9 / 12	25	1800 / 1800
NSL125-415	9 / 13	26	1800 / 1800	NSL300-525	14	25	1800 / 1800
NSL150-215	8	16	----- / 1800				

The above-mentioned max. working pressure is **NOT** valid for pumps approved by a classification society. Pumps approved by classification societies have been pressure tested according to the requirements of these societies, i.e. a test pressure of 1.5 x the permissible working pressure. The test pressure is stated in the test certificate and stamped into the discharge flange of the pump.

14. EU & UK DECLARATION OF CONFORMITY

DESMI PUMPING TECHNOLOGY A/S, hereby declare that our pumps of the type NSL Compact Spacer are manufactured in conformity with the following essential safety and health requirements in the COUNCIL DIRECTIVE 2006/42/EC on machines, Annex 1.

The following harmonized standards have been used:

EN/ISO 13857:2008	Safety of machinery. Safety distances to prevent danger zones being reached by the upper limbs
EN 809:1998 + A1:2009	Pumps and pump units for liquids – Common safety requirements
EN12162:2001+A1:2009	Liquid pumps – Safety requirements – Procedure for hydrostatic testing
EN 60204-1:2006/A1:2009	Safety of machinery – Electrical equipment of machines (item 4, General requirements)
Ecodesign Directive (2009/125/EC).	Water pumps: Commission Regulation No 547/2012. Applies only to water pumps marked with the minimum efficiency index MEI. See pump nameplate.

Pumps delivered by us connected with prime movers are CE-marked and comply with the above requirements.

Pumps delivered by us without prime movers (as partly completed machinery) must only be used when the prime mover and the connection between prime mover and pump comply with the above requirements.

Nørresundby, August 12 2021

Henrik Mørkholt Sørensen
Managing Director

DESMI Pumping Technology A/S
Tagholm 1
9400 Nørresundby

15. INFORMATION RELEVANT FOR DISASSEMBLY OR DISPOSAL AT END-OF-LIFE

No damage materials are used in DESMI pumps – please refer to DESMI Green Passport (can be sent on request – contact a DESMI sales office) – i.e. common recycling companies can handle the disposal at end-of-life. Alternatively the pump and motor can be returned to DESMI at end-of-life for safe recycling.

16. ASSEMBLY DRAWING $\varnothing 215/265$

17. SPARE PARTS LIST $\varnothing 215/265$ See $\varnothing 330/415$ pump on the next pages

2 Pipe plug

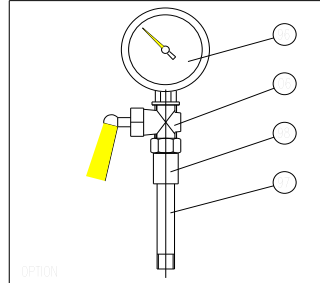

1 Pump casing

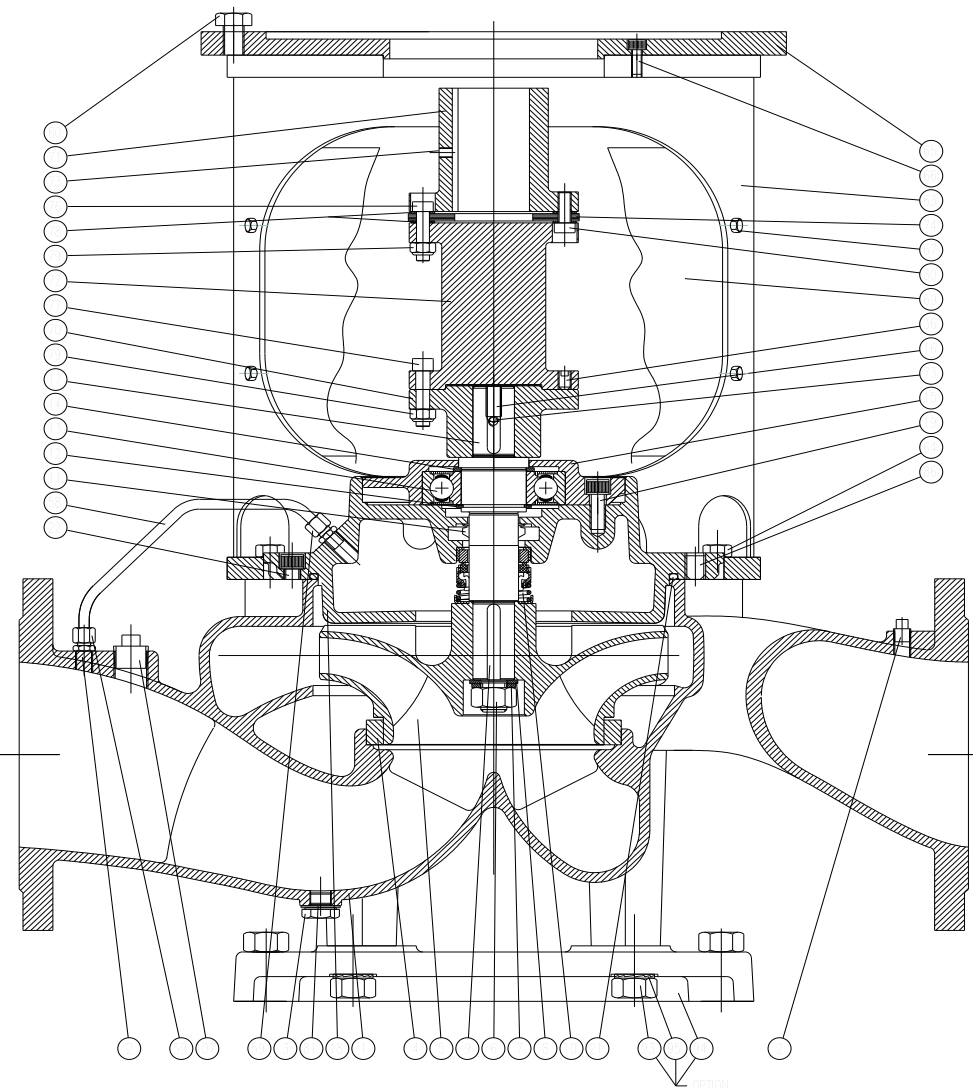

3 Pipe plug

4 Sealing ring

5 Impeller

6 Nut

7 Spring collar

8 Washer

9 Sunk key

10 Shaft seal

11 Water deflector

12 Ring lock

13 Ball bearing

14 Support disc

15 Bearing cover

16 Sunk key

17 Shaft

18 Shaft seal cover

19 Allen screw

21 O-ring

22 Allen screw

36 Pointed screw

58 Copper pipe

59 Hexagon nipple

60 Set screw

63 Motor bracket

64 Set screw

65 Intermediate flange *)

66 Allen screw *)

67 Set screw

69 Guard

70 Coupling part pump

71 Coupling part motor

72 Spacer

73 Pointed screw

74 Coupling discs

76 Allen screw

77 Allen screw

78 Washer

79 Pinch nut

80 Allen screw

81 Sealing washer

86 Pointed screw

93 Set screw

94 Base plate

95 Lock washer

96 Pressure gauge

97 Nipple

98 Sleeve

106 Pressure gauge cock

107 Pipe plug

*) Only if motor is bigger than motor bracket

18. ASSEMBLY DRAWING ø330/415 with light bearing housing (80-330, 100-330, 125-330, 100-415 and 125-415)

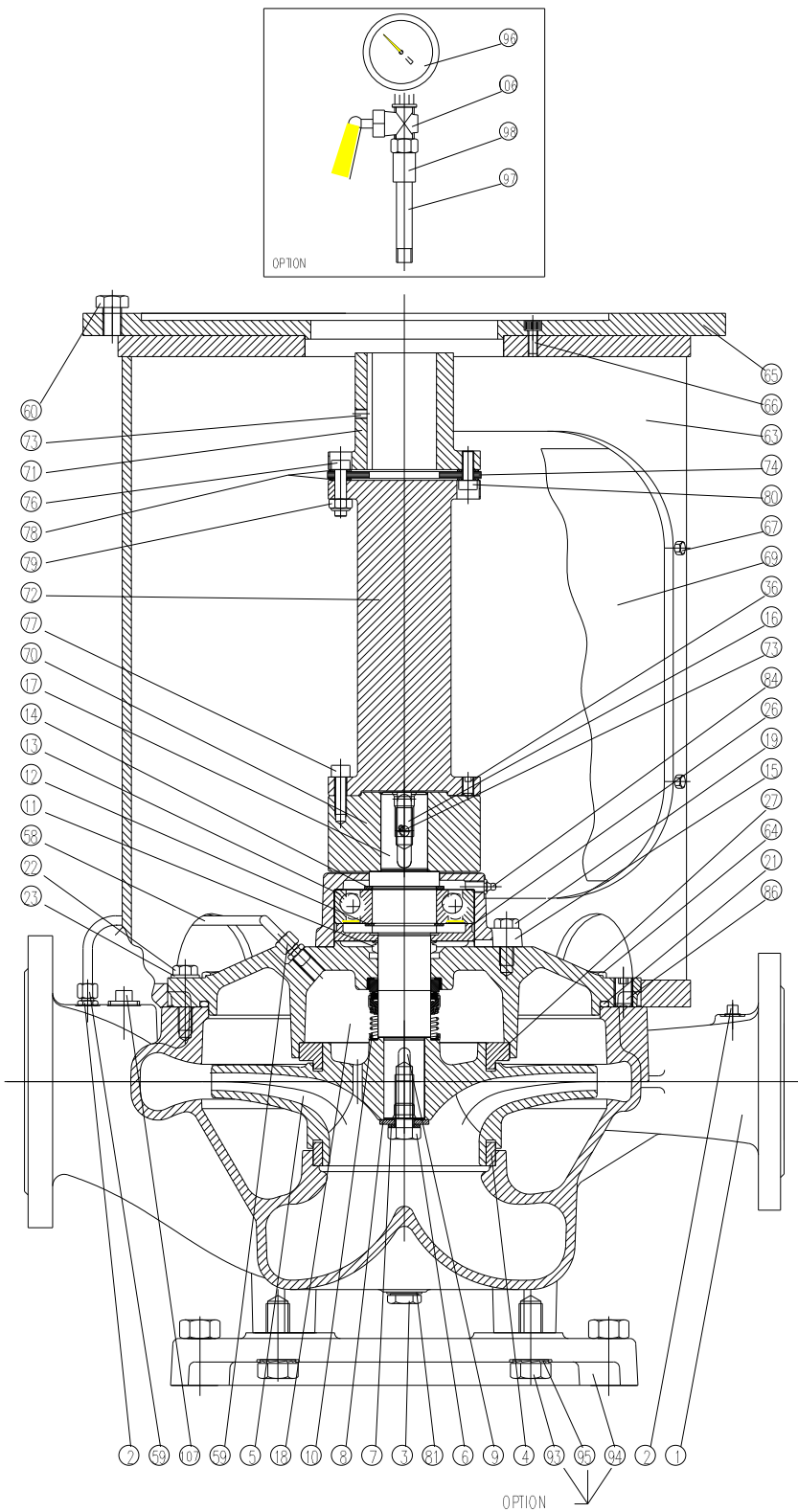

19. SPARE PARTS LIST ø330/415 with light bearing housing

- | | |
|-----|-----------------------|
| 1 | Pump casing |
| 2 | Pipe plug |
| 3 | Pipe plug |
| 4 | Sealing ring |
| 5 | Impeller |
| 6 | Nut |
| 7 | Spring collar |
| 8 | Washer |
| 9 | Sunk key |
| 10 | Shaft seal |
| 11 | Water deflector |
| 12 | Ring lock |
| 13 | Ball bearing |
| 14 | Support disc |
| 15 | Bearing cover |
| 16 | Sunk key |
| 17 | Shaft |
| 18 | Shaft seal cover |
| 19 | Allen screw |
| 21 | O-ring |
| 22 | Allen screw |
| 27 | Sealing ring 2 |
| 36 | Pointed screw |
| 58 | Copper pipe |
| 59 | Hexagon nipple |
| 60 | Set screw |
| 63 | Motor bracket |
| 64 | Set screw |
| 65 | Intermediate flange*) |
| 66 | Allen screw*) |
| 67 | Set screw |
| 69 | Guard |
| 70 | Coupling part pump |
| 71 | Coupling part motor |
| 72 | Spacer |
| 73 | Pointed screw |
| 74 | Coupling discs |
| 76 | Allen screw |
| 77 | Allen screw |
| 78 | Washer |
| 79 | Pinch nut |
| 80 | Allen screw |
| 81 | Sealing washer |
| 86 | Pointed screw |
| 93 | Set screw |
| 94 | Base plate |
| 95 | Lock washer |
| 96 | Pressure gauge |
| 97 | Nipple |
| 98 | Sleeve |
| 106 | Pressure gauge cock |
| 107 | Pipe plug |

*) Only if motor is bigger than motor bracket

20. ASSEMBLY DRAWING ø330/415 with heavy bearing housing

21. SPARE PARTS LIST ø330/415 with heavy bearing housing

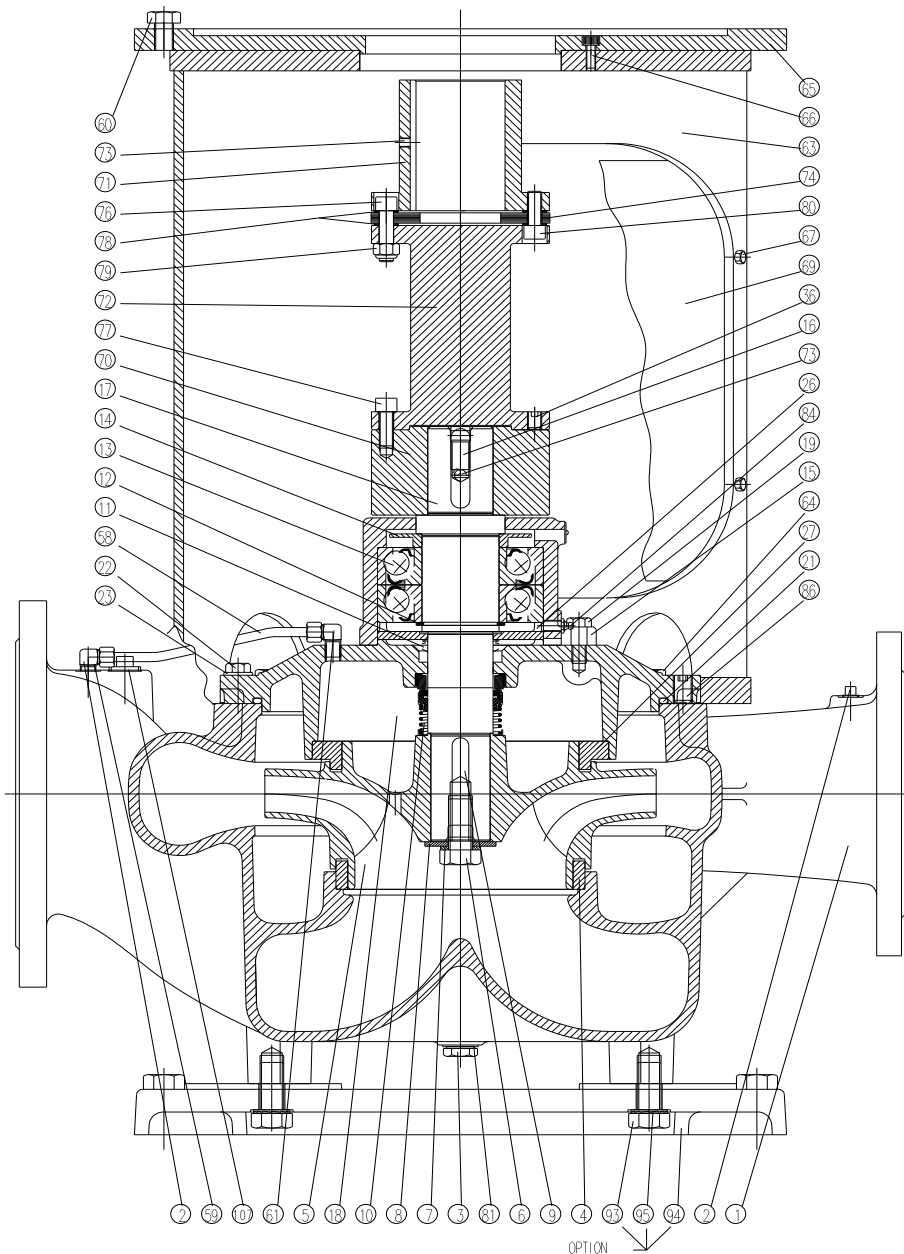
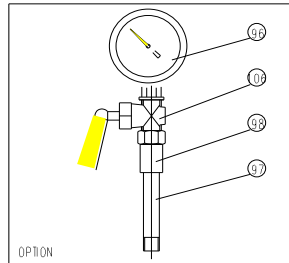

- 1 Pump casing
- 2 Pipe plug
- 3 Pipe plug
- 4 Sealing ring
- 5 Impeller
- 6 Nut
- 7 Spring collar
- 8 Washer
- 9 Sunk key
- 10 Shaft seal
- 11 Water deflector
- 12 Ring lock
- 13 Ball bearing
- 14 Grease valve ring
- 15 Bearing cover
- 16 Sunk key
- 17 Shaft
- 18 Shaft seal cover
- 19 Allen screw
- 21 O-ring
- 22 Allen screw
- 27 Sealing ring 2
- 36 Pointed screw
- 58 Copper pipe
- 59 Hexagon nipple
- 60 Set screw
- 61 Hexagon nipple
- 63 Motor bracket
- 64 Set screw
- 65 Intermediate flange*)
- 66 Allen screw*)
- 67 Set screw
- 69 Guard
- 70 Coupling part pump
- 71 Coupling part motor
- 72 Spacer
- 73 Pointed screw
- 74 Coupling discs
- 76 Allen screw
- 77 Allen screw
- 78 Washer
- 79 Pinch nut
- 80 Allen screw
- 81 Sealing washer
- 86 Pointed screw
- 93 Set screw
- 94 Base plate
- 95 Lock washer
- 96 Pressure gauge
- 97 Nipple
- 98 Sleeve
- 106 Pressure gauge cock
- 107 Pipe plug

*) Only if motor is bigger than motor bracket

22. DIMENSIONAL SKETCH $\varnothing 215/265$

See $\varnothing 330/415$ pumps on the next pages

Manometer: 1/4" BSP. Drain: 3/8" BSP. Priming: 1/2" BSP

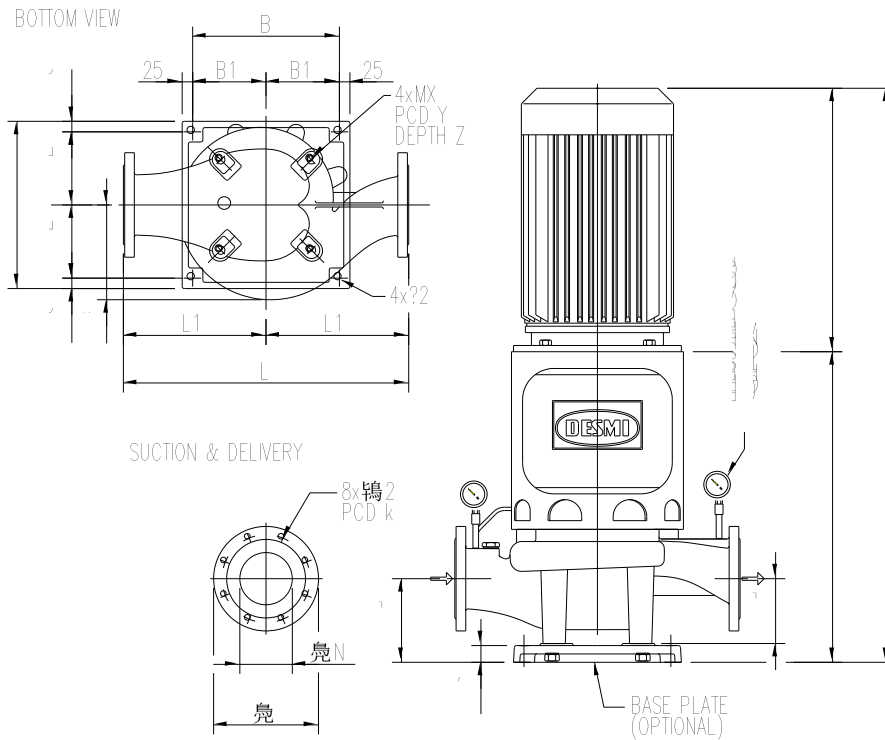

Type	H	h1	h2	L	L1	W	DN	D	d2	k	X	Y	Z	B	B1
NSL80-215	693	200	155	530	265	163	80	200	18	160	20	306	25	350	175
NSL80-265	700	200	155	580	290	193	80	200	18	160	20	306	25	350	175
NSL100-215	714	200	155	580	290	181	100	220	18	180	20	306	25	350	175
NSL100-265	720	200	155	630	315	193	100	220	18	180	20	306	25	350	175
NSL125-215	727	200	155	630	315	203	125	250	18	210	20	306	25	350	175
NSL125-265	743	200	155	680	340	227	125	250	18	210	20	306	25	350	175
NSL150-215	763	230	185	680	340	239	150	285	22	240	20	306	25	350	175
NSL150-265	767	200	155	730	365	250	150	285	22	240	20	306	25	350	175
NSL200-265	808	260	215	780	390	290	200	340	23	295	20	306	25	350	175
NSL250-265	835	260	215	800	400	324	250	405	22	350	20	306	25	350	175

23. DIMENSIONAL SKETCH $\varnothing 330/415$

Manometer: 1/4" BSP. Drain: 3/4" BSP. Priming: 1/2" BSP

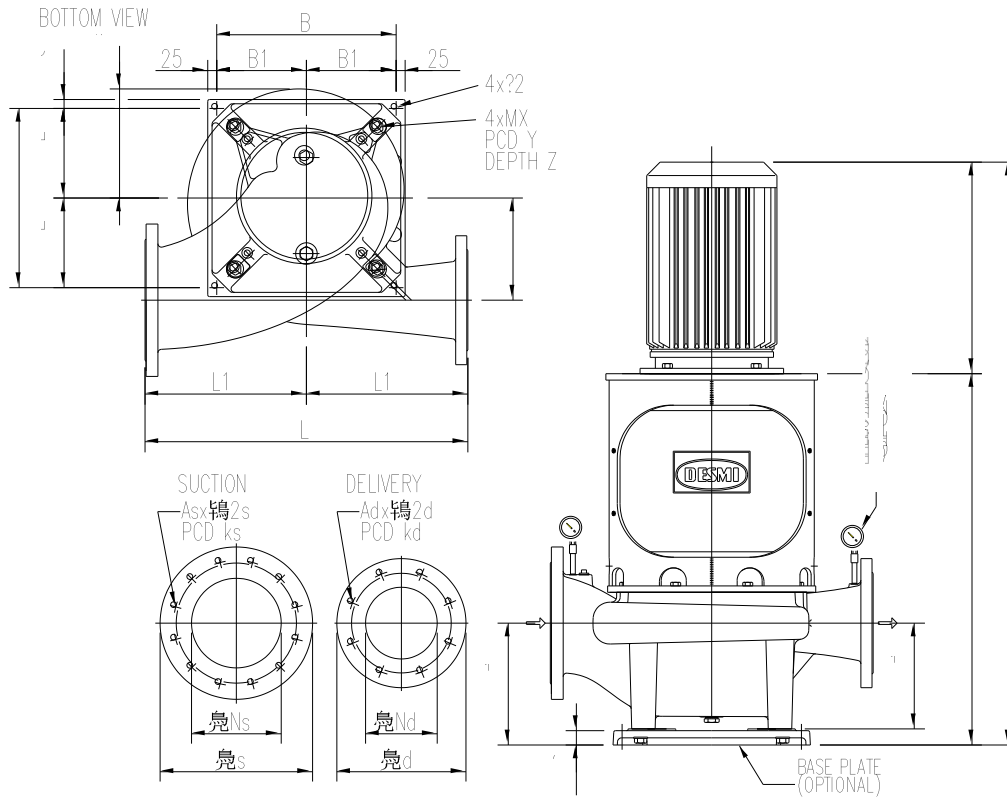

Type	H	h1	h2	L	L1	W	Ds A- exe.	Dd A- exe.	Ds D- exe.	Dd D- exe.	DNs	DNd	ks	kd
NSL80-330	894	260	215	600	300	250	235	200	220	200	100	80	180	160
NSL100-330	899	260	215	650	325	250	270	235	250	220	125	100	210	180
NSL100-415	922	260	215	700	350	275	270	235	250	220	125	100	210	180
NSL125-330	945	300	255	700	350	250	300	270	285	250	150	125	240	210
NSL125-415	960	300	255	750	375	278	300	270	285	250	150	125	240	210
NSL150-330	955	300	255	750	350	275	360	300	340	285	200	150	295	240
NSL150-415	1006	340	295	800	400	293	360	300	340	285	200	150	295	240
NSL200-330	998	340	295	900	450	301	425	360	395	340	250	200	350	295
NSL200-415	1076	340	295	900	450	308	425	360	395	340	250	200	350	295
NSL250-330	1045	380	335	1000	500	327	485	425	445	395	300	250	400	350

NSL250-415	1118	380	335	1000	500	355	485	425	445	395	300	250	400	350
NSL300-415	1164	420	375	1200	600	377	555	485	505	445	350	300	460	400

Type	d2s	d2d	As	Ad	X	Y	Z	B	B1	O
NSL80-330	18	18	8	8	20	306	25	350	175	200
NSL100-330	18	18	8	8	20	306	25	350	175	210
NSL100-415	18	18	8	8	20	450	25	500	250	250
NSL125-330	22	18	8	8	20	306	25	350	175	225
NSL125-415	22	18	8	8	20	450	25	500	250	260
NSL150-330	22	22	8	8	20	450	25	500	250	235
NSL150-415	22	22	8	8	20	450	25	500	250	275
NSL200-330	22	22	12	8	20	450	25	500	250	260
NSL200-415	22	22	12	8	24	560	28	500	250	285
NSL250-330	22	22	12	12	24	560	28	500	250	275
NSL250-415	22	22	12	12	24	560	28	500	250	305
NSL300-415	22	22	16	12	24	560	28	500	250	320