

OPERATION AND MAINTENANCE INSTRUCTION

DESMI “in-line” centrifugal pump Type DSL



DESMI Pumping Technology A/S

Manual: T1513	Language: English	Revision: R (11/22)
------------------	----------------------	------------------------

Special pump no.

Contents

1. PRODUCT DESCRIPTION	2
1.1 DELIVERY	2
2. TECHNICAL DATA	2
2.1 ACCESSORIES	2
2.2 SPACE AROUND THE PUMP	2
2.3 EXPLANATION OF THE TYPE NUMBER	3
2.4 TECHNICAL DESCRIPTION	4
3. INSTALLATION	5
3.1 MOUNTING/FASTENING	5
3.2 WIRING	6
4. TRANSPORT/STORAGE	6
5. DISMANTLING	7
5.1 DISMANTLING FOR DSLXXX-YYY/G AND DSLXXX-YYY/G-U	7
5.1.1 DISMANTLING COUPLING FOR DSLXXX-YYY/G	7
5.1.2 DISMANTLING COUPLING FOR DSLXXX-YYY/G-U	8
5.1.3 DISMANTLING SHAFT SEAL FOR DSLXXX-YYY/G	9
5.1.4 DISMANTLING SHAFT SEAL & BEARING HOUSE FOR DSLXXX-YYY/G-U	10
5.1.5 DISMANTLING MOTOR BRACKET, REAR COVER AND IMPELLER	11
5.2 DISMANTLING FOR DSLXXX-YYY/B-U	14
5.2.1 DISMANTLING COUPLING AND BEARING	14
5.2.2 DISMANTLING SHAFT SEAL	15
5.2.3 DISMANTLING THE IMPELLER AND REAR COVER	16
6. ASSEMBLING	17
7. FROST PROTECTION	17
8. DISMANTLING	17
9. START-UP	17
9.1 STARTING	18
10. SYSTEM BALANCING	18
10.1 FAULT-FINDING CHART	19
11. INSPECTION AND MAINTENANCE	20
11.1 INSPECTION DURING OPERATION	20
11.2 DRAINING THE PUMP	21
11.3 INSPECTION	21
11.4 LUBRICATING BEARINGS	21
12. REPAIRS	23
13. OPERATING DATA	23
14. EU & UK DECLARATION OF CONFORMITY	24
15. INFORMATION RELEVANT FOR DISASSEMBLY OR DISPOSAL AT END-OF-LIFE:	25

16. ASSEMBLY DRAWING	26
16.1 DSL150-265/-G	26
16.2 DSL250-310/-G AND DSL250-360/-G.....	29
16.3 DSL300-320/-G	32
16.4 DSL300-495/-G, DSL300-430/-G, DSL350-460/-G AND DSL400-460/-G	35
16.5 DSL400-498/-G	38
16.6 DSL450-490/-G AND DSL500-490/-G.....	41
16.7 DSL450-490/-G-U	44
16.8 DSL500-515/B-U,DSL300-320/-B-U.....	47
16.9 DSL500-515/-G-U	50
17. LAYOUT DRAWING	53
17.1 LAYOUT DRAWING OF DSL150-265/-G-I.....	53
17.2 LAYOUT DRAWING OF DSL250-310/-G	55
17.3 LAYOUT DRAWING OF DSL250-360/-G.....	56
17.4 LAYOUT DRAWING OF DSL300-320/-G	57
17.5 LAYOUT DRAWING OF DSL300-430/-G.....	58
17.6 LAYOUT DRAWING OF DSL300-495/-G	59
17.7 LAYOUT DRAWING OF DSL350-460/-G.....	60
17.8 LAYOUT DRAWING OF DSL400-460/-G	61
17.9 LAYOUT DRAWING OF DSL400-498/-G-I.....	62
17.10 LAYOUT DRAWING OF DSL450-490/-G.....	63
17.11 LAYOUT DRAWING OF DSL500-490/-G.....	64
17.12 LAYOUT DRAWING OF DSL500-515/-B-U	65
17.13 LAYOUT DRAWING OF DSL500-515/-G-U	66

1. PRODUCT DESCRIPTION

These operation and maintenance instructions apply to the DESMI DSL-pump series, in spacer and compact design. The pumps are available in sizes ranging from DN150 to DN500 on the discharge flange. The suction flange is bigger than the discharge flange in sizes DN150, DN250, DN300, DN400, DN450 and DN500, except DSL500-515 which suction flange is same with the discharge flange.

The DESMI DSL-pump is a 1-stage centrifugal pump with stainless steel shaft, mechanical shaft seal and closed impeller of the double-suction type.

The pump is suitable for the pumping of liquids with temperatures up to 80°C. With special shaft seal and bearings up to 140°C. For pumping liquids with temperatures above 100°C DESMI recommends using nothing but ductile iron (for instance GGG40) for pump casing and rear cover. Max. working pressure and number of revolutions are indicated under Operating Data.

The pump is a so-called "in-line" type, i.e. suction and pressure branches are mounted on the center line. It is vertical with impeller of the double-suction type with double-curved blades, and it has a helical pump casing in one casting.

The pump is driven by an electric motor which may be a standard AC motor or a DC motor.

1.1 DELIVERY

- Check on delivery that the shipment is complete and undamaged.
- Defects and damages, if any, to be reported to the carrier or the supplier immediately in order that a claim can be advanced.

2. TECHNICAL DATA

The pumps are manufactured in various material combinations which appear from the type number on the name plate. See paragraph 2.3.

2.1 ACCESSORIES

As extra equipment the pump may be mounted with a priming pump of the water ring type, complete with filter and feed water tank, or it may be delivered with a priming ejector driven by pressurized air.

Manometers for are mounted on request.

2.2 SPACE AROUND THE PUMP

On the spacer pump it is possible to dismantle the impeller and the shaft without dismantling the electric motor. Therefore, no minimum distance is required above the electric motor. The ventilation of the motor should, however, be taken into consideration.

On the compact pump the motor and the motor bracket must be removed before dismantling shaft and impeller. This means that there is to be so much space above the motor that motor with brackets can be lifted abt. 250 mm up.

Generally, there is to be sufficient space in front of the pump to allow inspection of the shaft seal for leaks and dismantling of the coupling and the internal parts of the pump. It must also be possible to dismantle the entire pump, if required.

2.3 EXPLANATION OF THE TYPE NUMBER

All the DSL-pumps are provided with a name plate. The type of number indicated on the name plate is built up as follows:

DSLXXX-YYY/M-R or DSLXXX-YYYZ/M-R

XXX : Diameter DN (mm) of the pressure branch.

YYY : Diameter (mm) of standard impeller.

M : The material combination of the pump.

R : The assembly combination of the pump.

Z : Special impeller design (B, C, D, E, F).

R may be the following:

A : Spacer design.

B : Spacer design without bottom bearing.

F : Compact design.

G : Compact design without bottom bearing.

I : With PN 16 flanges.

J : With PN 25 flanges.

K : Identical suction and pressure

L : Other shaft seal.

M : BS-flanges.

N : ANSI-flanges.

O : Shock-proof combination.

P : Other combination.

Q : JIS-flanges.

U : /-B or /-G design with top ball bearing

M may be the following:

Material combination	A	C	D	Q	S
Pump casing	Cast iron	Cast iron	Bronze or NiAlBz	Spec. bronze	Stainless steel
Impeller	NiAlBz	Cast iron	NiAlBz or SS	Spec. bronze	Stainless steel
Sealing ring	NiAlBz	Cast iron	NiAlBz or SS	Spec. bronze	Stainless steel
Rear cover	Cast iron	Cast iron	Bronze or NiAlBz	Spec. bronze	Stainless steel
Shaft	Stainless steel	Stainless steel	Stainless steel	Stainless steel	Stainless steel
Shaft seal	Mechanical	Mechanical	Mechanical	Mechanical	Mechanical
Elastomer	Nitrile*	Nitrile*	Nitrile*	Nitrile*	Nitrile*

Note SS = stainless steel

*) : Or VITON or EPDM

Before putting a pump into operation, the suitability of the material combination of the pump must always be taken into consideration. In case of doubt, contact the supplier.

The pump is particularly suitable for the pumping of water in connection with the cooling of diesel engines and cooling units, as ballast pump, and for waterworks and district heating stations.

Pumps in material combinations A and C are primarily used for fresh water.
 Pumps in material combination D are primarily used for sea water.
 If the pumps are designed for special purposes, the following is to be indicated:

Pump No. : _____
 Pump type : _____
 Application : _____
 Comment : _____

2.4 TECHNICAL DESCRIPTION

The pumps are as a standard equipped with an electric motor with protection class IP 54. This means that the motor is protected against penetrating dust, and that splashes of water without pressure do not ruin the motor. If the pumps are installed in explosive areas, they must be equipped with explosion-proof motors. The motors are designed for continuous operation at a max. ambient temperature of 40°C.



The following table indicates the max. permissible number of revolutions for the individual pump types:

Notice: Some pump combinations allow higher speeds than stated – see actual pump name plate.

Pump type	Motors: 6-pole / 50 Hz 6-pole / 60 Hz	Motors: 4-pole / 50 Hz 4-pole / 60 Hz	Motors: 2-pole / 50 Hz 2-pole / 60 Hz
DSL150-265			√
DSL 250-310		√	
DSL 250-360		√	
DSL300-320		√	
DSL300-430		√	
DSL300-495		√	
DSL350-460		√	
DSL 400-460		√	
DSL 400-498	√		
DSL 450-490	√		
DSL 500-490	√		
DSL 500-515	√		

The noise level of the pump depends on the motor type supplied, as the noise from the pump can be calculated as the noise level of the motor + 2 dB (A).

The capacity of the pump appears on the name plate of the pump. If the pump has been delivered without motor, the pump capacity is to be indicated on the plate when mounting the motor.
 The permissible loads on the flanges are stated in the table below:

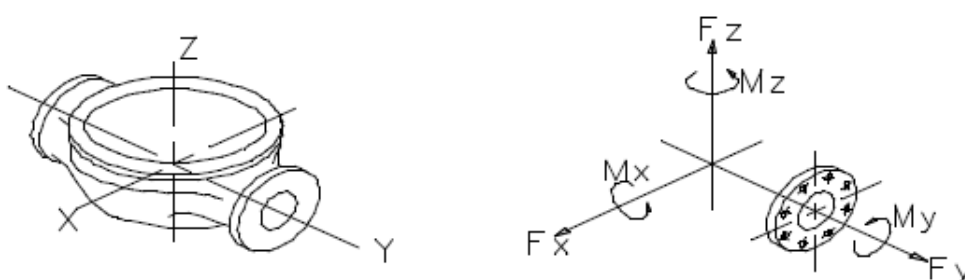

Pump type	DN	Forces (N)				Torques (Nm)			
		Fy	Fz	Fx	ΣF	My	Mz	Mx	ΣMt
DSL150-265	150	1500	1900	1700	2950	1000	650	800	1400
DSL250-310	250	2500	3150	2820	4900	1770	1140	1400	2470
DSL250-360	250	2500	3150	2820	4900	1770	1140	1400	2470
DSL300-320	300	3000	3750	3350	5860	2750	1900	2200	4000
DSL300-430	300	3000	3750	3350	5860	2750	1900	2200	4000
DSL300-495	300	3000	3750	3350	5860	2750	1900	2200	4000
DSL350-460	350	3500	4370	3920	6840	3630	2500	2930	5300
DSL 400-460	400	4000	5000	4480	7820	4600	3200	3700	6720
DSL 400-498	400	4000	5000	4480	7820	4600	3200	3700	6720
DSL 450-490	450	4540	5610	5040	8800	5720	4000	4650	8390
DSL 500-490	500	5040	6225	5600	9770	6975	4875	5650	10400
DSL 500-515	500	5040	6225	5600	9770	6975	4875	5650	10400

In connection with the permissible loads on the flanges stated in the above table there is also the following limitation:

$$\left\{ \frac{\sum F \text{ calc}}{\sum F} \right\}^2 + \left\{ \frac{\sum M \text{ calc}}{\sum M t} \right\}^2 < 2$$

Where index "calc" is the values calculated by the user.

The permissible loads on the flanges appear from the following table. The values apply to standard pumps in bronze (Rg5) and cast iron (GG20). As to pumps in SG iron (GGG40), NiAlBz or stainless steel the values are to be increased by a factor 1.5.

At the same time, none of the forces or moments may exceed the indicated figure multiplied by 1.4.

3. INSTALLATION

See also: DESMI Guidelines for pump installations at:
www.desmi.com/media/sd5ltlox/guidelines_uk.pdf

3.1 MOUNTING/FASTENING

The pump should be mounted and fastened on a solid base plate with a flat and horizontal surface to avoid distortion.

The max. permissible loads on the flanges indicated in paragraph 2.4 are to be observed.



At installations pumping hot or very cold liquids the operator must be aware that it is

dangerous to touch the pump surface, and, consequently, he must take the necessary safety measures.

3.2 WIRING



Wiring to be carried out by authorized skilled workmen according to the rules and regulations in force.

4. TRANSPORT/STORAGE

See also: DESMI Pump Storage and Preservation at: www.desmi.com/media/vqkjqh54/t1534uk.pdf

The pumps are to be lifted as shown on the figure. The weight appears from the table below.

The pump is to be stored in a dry area.

The center of gravity of the pump is on the center line of the shaft.

Before shipment the pump is to be fastened and supported securely on a pallet or the like.



The pump is to be lifted as follows:

The lifting straps must not bear against sharp edges and corners.

The pump weights do not include motor.

PUMP TYPE	WEIGHT IN KG (SPACER) -A/-D	WEIGHT IN KG (COMPACT) -A/-D
DSL 150-265	-/-	305/337
DSL 250-310	-/-	497/555
DSL 250-360	-/-	537/600
DSL 300-320	-/-	590/665
DSL 300-430	-/-	906/-980
DSL 300-495	-/-	1162/1232
DSL 350-460	-/-	1229/1302
DSL 400-460	-/-	1185/1253
DSL 400-498	-/-	1885/-
DSL 450-490	-/-	-/1417
DSL 500-490	-/-	1881/1936
DSL 500-515	1893/2054	1690/1829

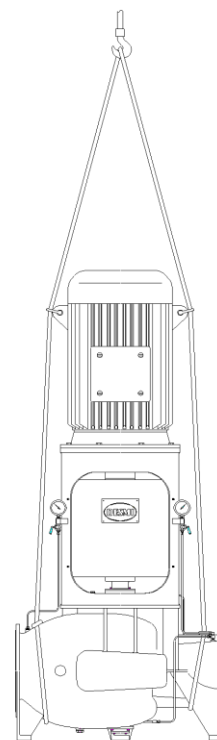

5. DISMANTLING

5.1 DISMANTLING FOR DSLxxx-yyy/G AND DSLxxx-yyy/G-U

5.1.1 DISMANTLING COUPLING FOR DSLxxx-yyy/G

Note: For pumps with top ball bearing the vertical gap between motor coupling hub and spacer shaft to be between 1 and 3 mm.

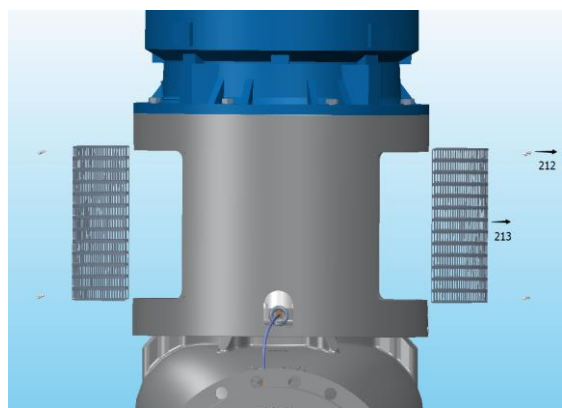

Remove pointed screw(212) and guard(213)

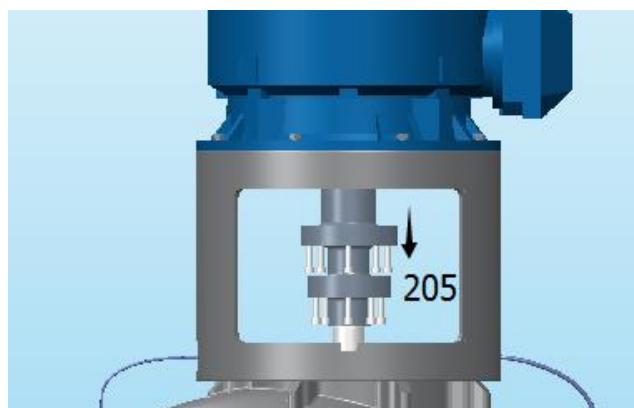

Remove Allen screw(205)

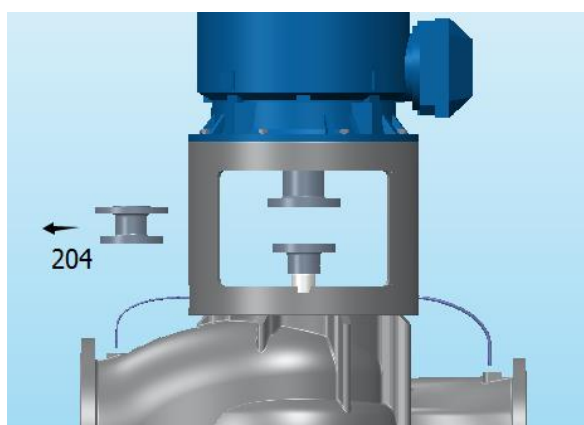

Remove the short spacer coupling (204)

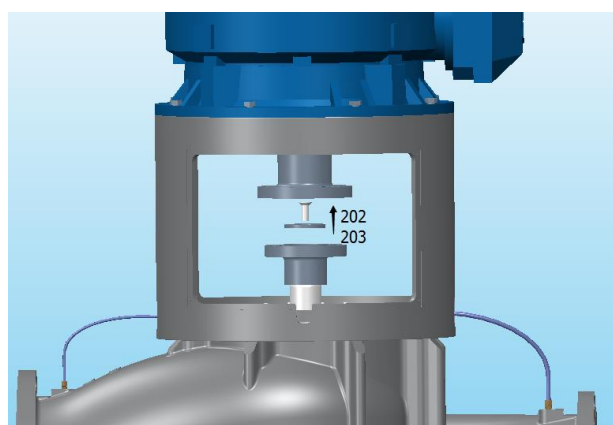

Remove screw (203) and plate (202)

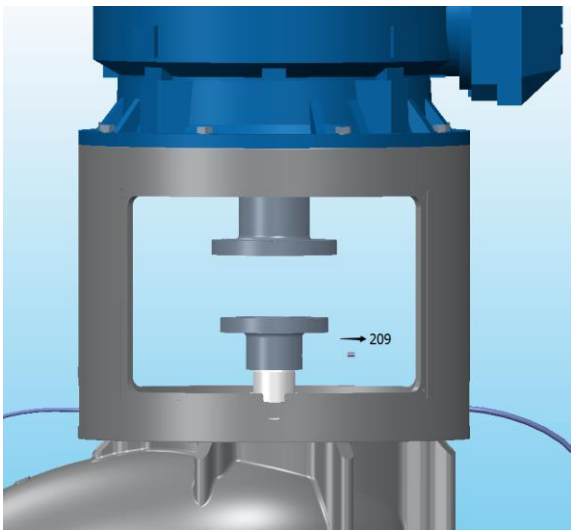

Remove the pointed screw (209)

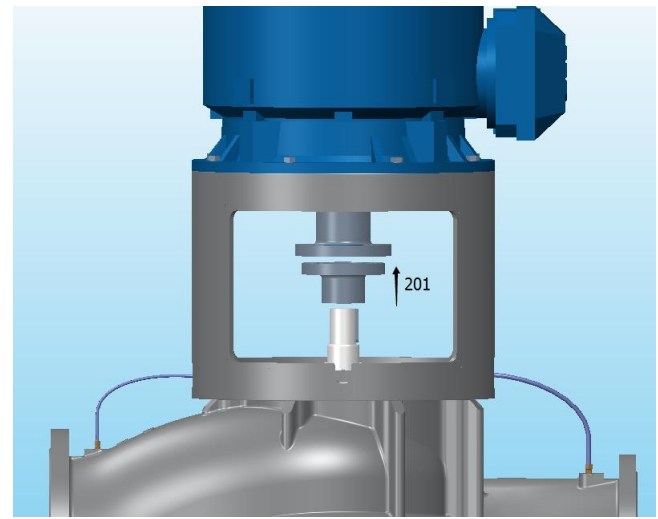

Remove the pump coupling (201)

5.1.2 DISMANTLING COUPLING FOR DSLXXX-YYY/G-U

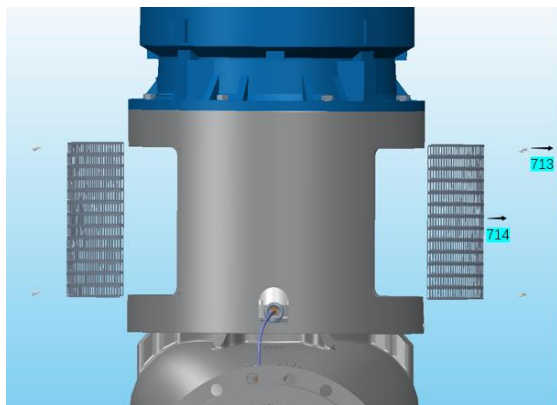

Remove pointed screw (713) and guard (714)

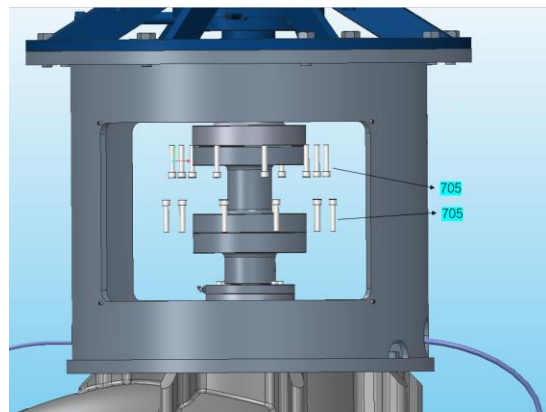

Remove Allen screw(705)

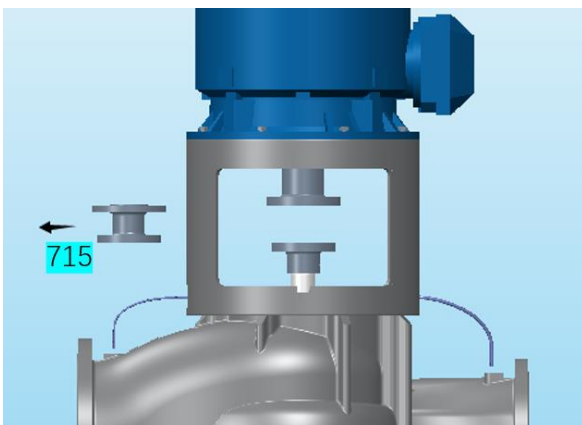

Remove the short spacer coupling (715)



Remove screw (719) and plate (709)

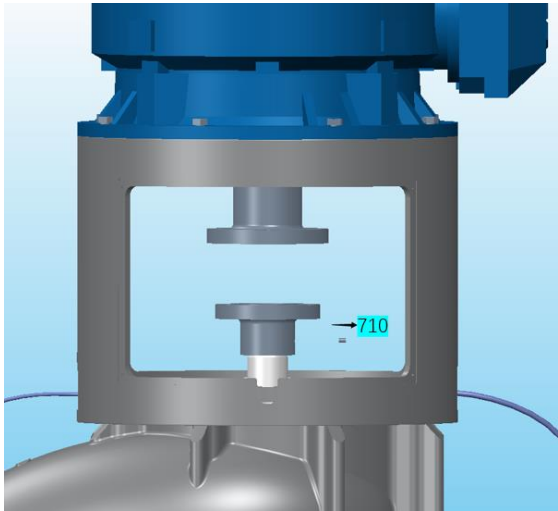

Remove the pointed screw (710)

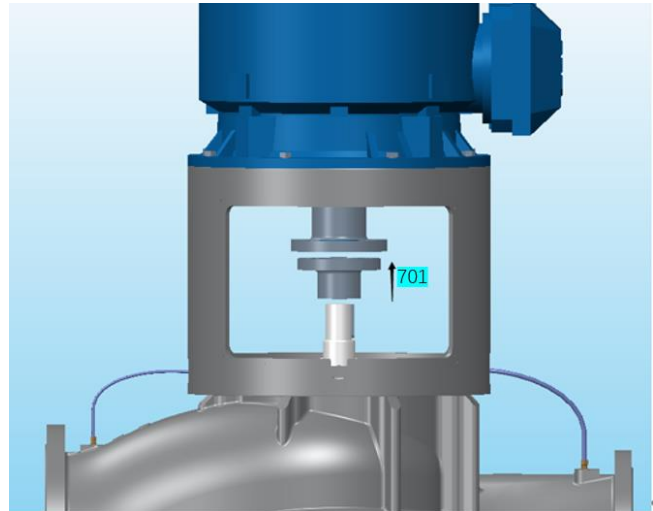

Remove the pump coupling (701)

5.1.3 DISMANTLING SHAFT SEAL FOR DSLXXX-YYY/G

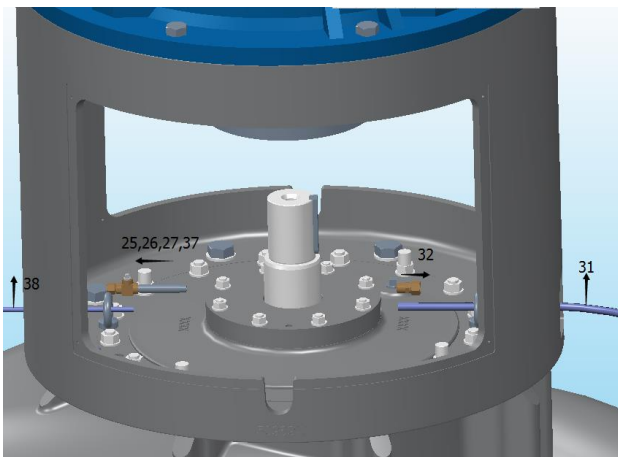

Remove the fittings (25,26,27,37,31,32,38)



Remove the key (21)

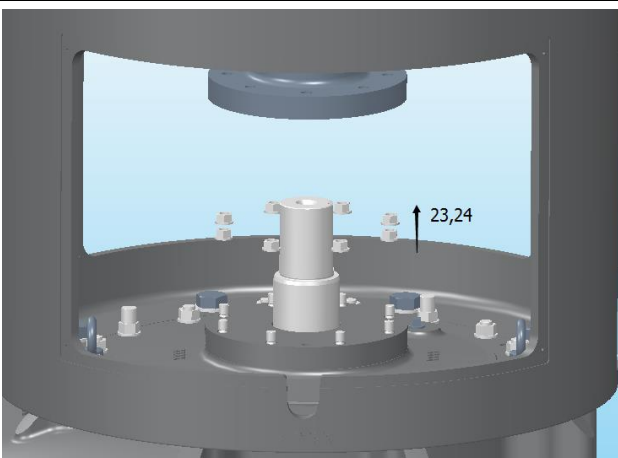

Remove the nut and washer (23,24)

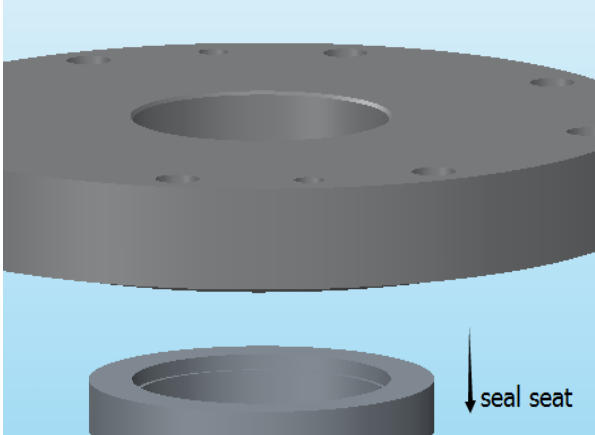
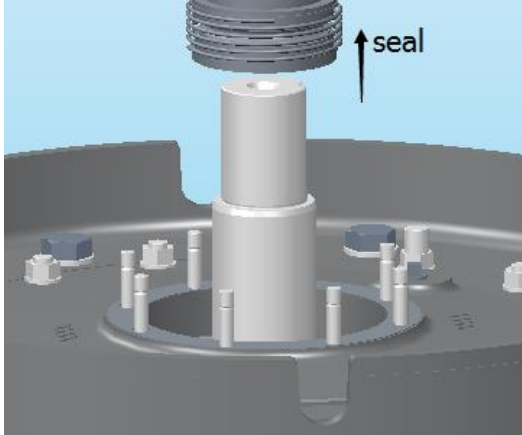

	<p>Remove the seal cover (22) with the stationary ring of the mechanical seal.</p> 
<p>Remove the mechanical seal seat</p>	<p>Remove the mechanical seal</p>
<p>NOTE: If ELK shaft seal then three radial pointed screws in the rotating part to be loosened before pulling up the rotating part. See Appendix A regarding assembly.</p>	

5.1.4 DISMANTLING SHAFT SEAL & BEARING HOUSE FOR DSLxxx-YYY/G-U

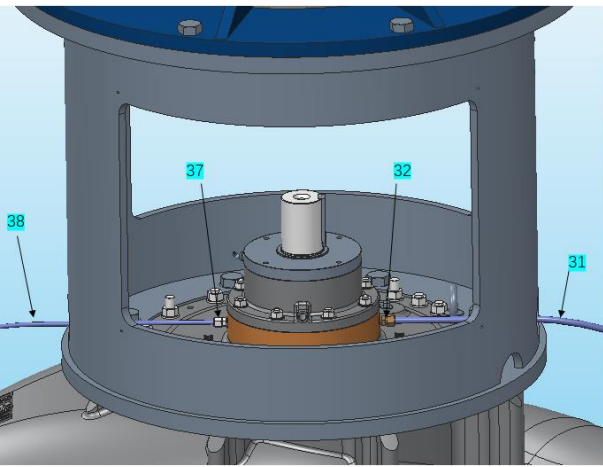
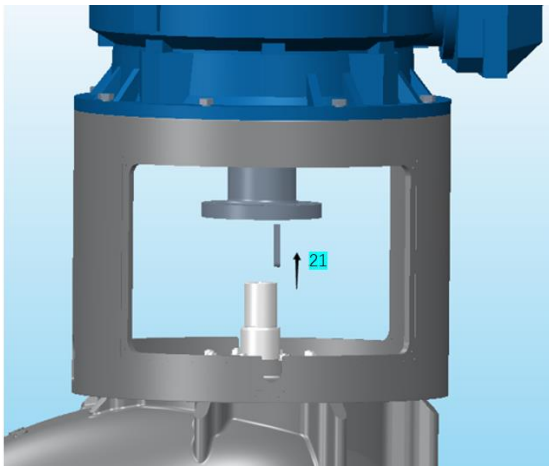
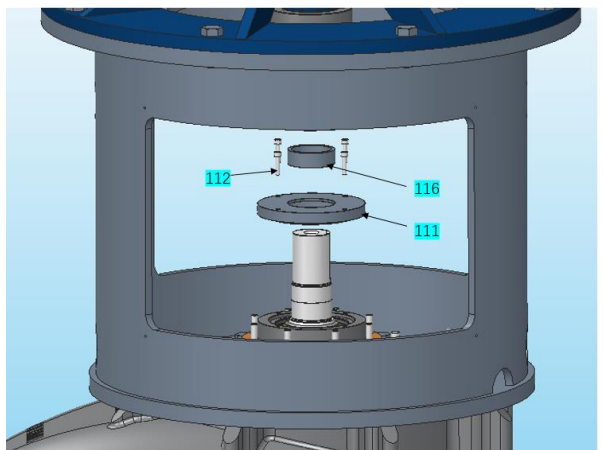
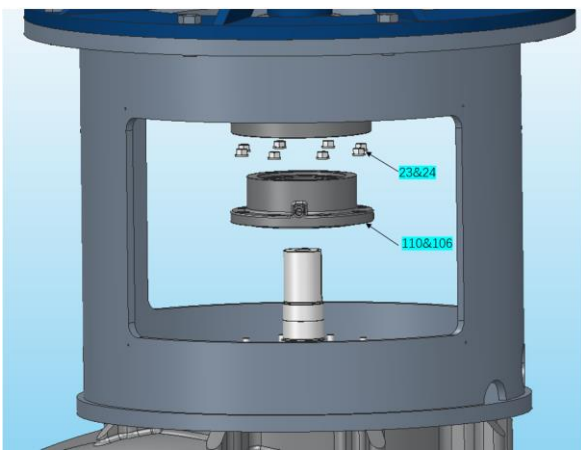
	
<p>Remove the pipe & fittings (31,32,37,38)</p>	<p>Remove the key (21)</p>
	

Unscrew (112), dismantle bearing cover (111) and take out the position ring (116)

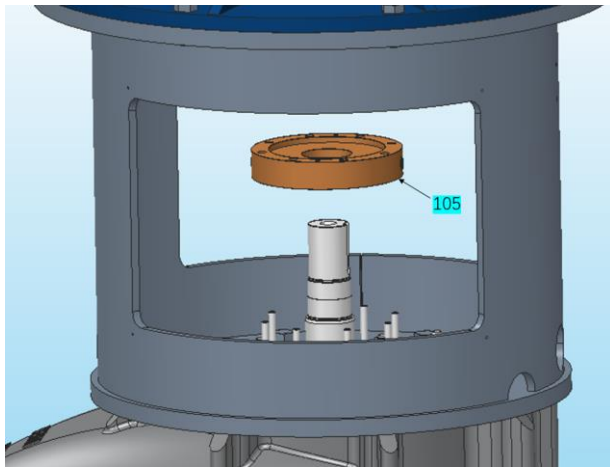

Remove the mechanical seal seat (105)

Unscrew nut & washer (23&24), then lift the bearing with bearing housing (110&106)

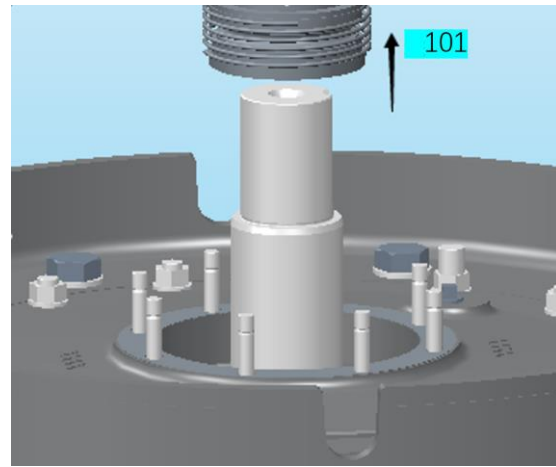

Remove the mechanical seal (101)

NOTE: If ELK shaft seal then three radial pointed screws in the rotating part to be loosened before pulling up the rotating part. See Appendix A regarding assembly.

5.1.5 DISMANTLING MOTOR BRACKET, REAR COVER AND IMPELLER

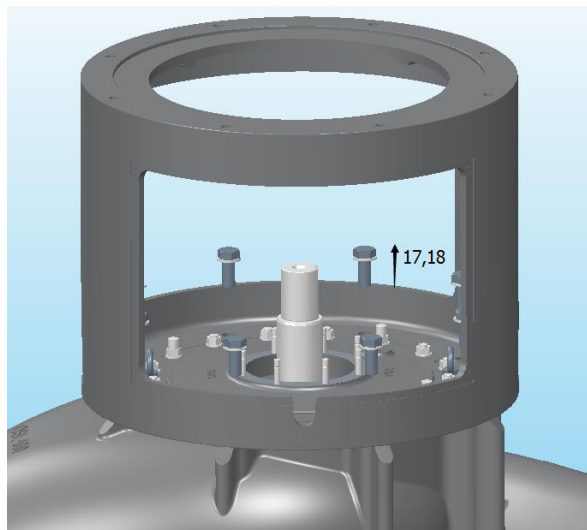

Remove the set screw (18) and washer (17)

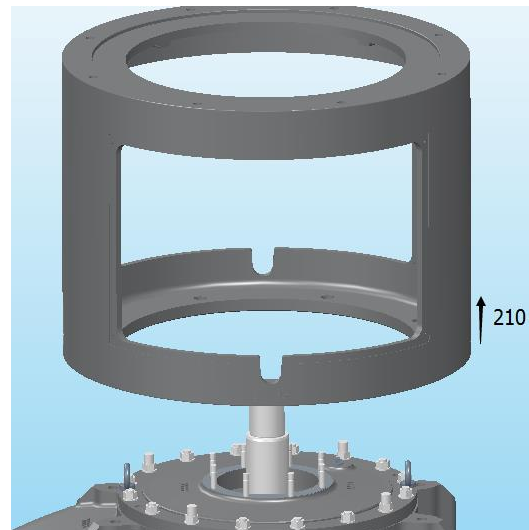

Remove the motor bracket (210)

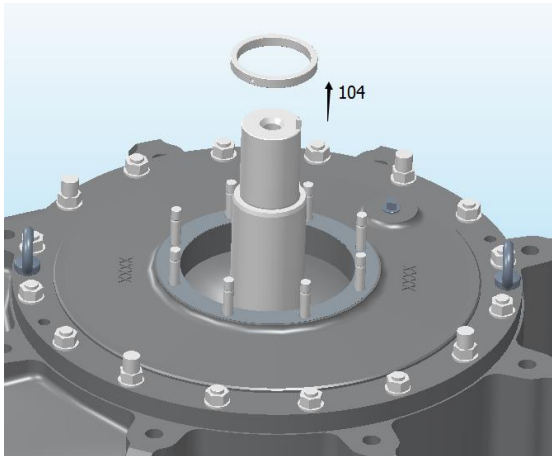

Remove the stop collar (104)

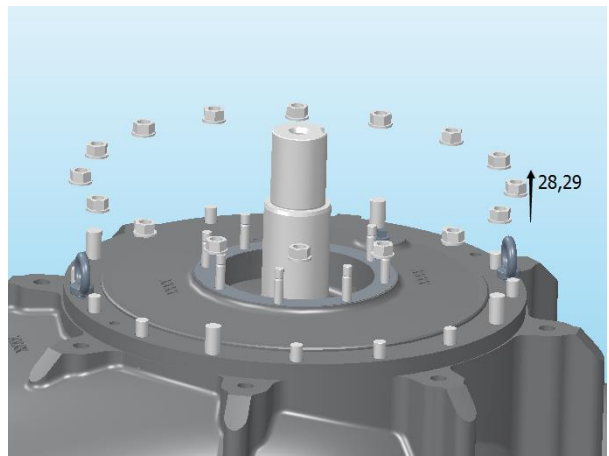

Remove the nut (29) and washer (28)

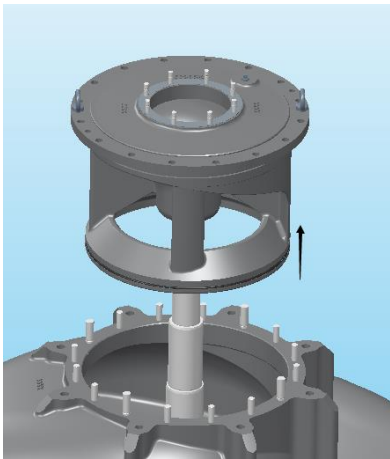

Remove the rear cover (2)

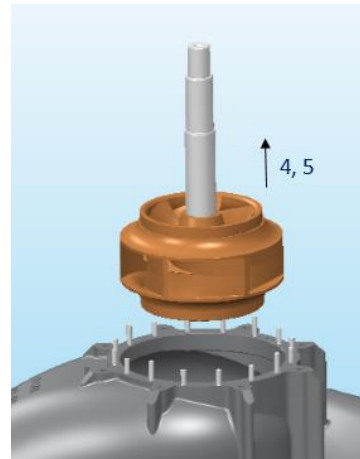

Remove the shaft (4) with impeller (5)

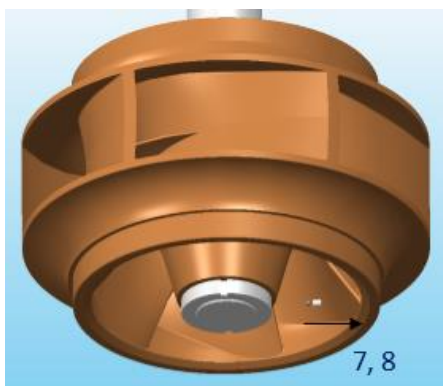

Remove the pointed screw (8) and plastic ball (7)

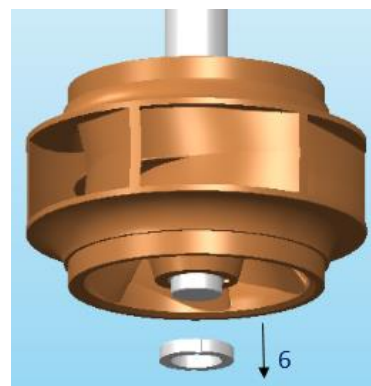

Remove the lock nut (6)

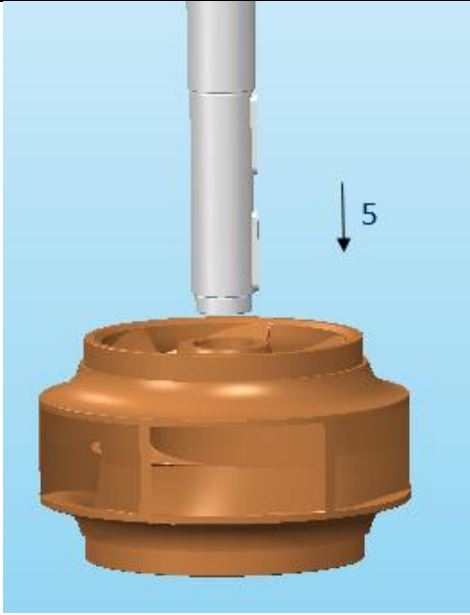

Remove the impeller (5)

5.2 DISMANTLING FOR DSLXXX-YYY/B-U

5.2.1 DISMANTLING COUPLING AND BEARING

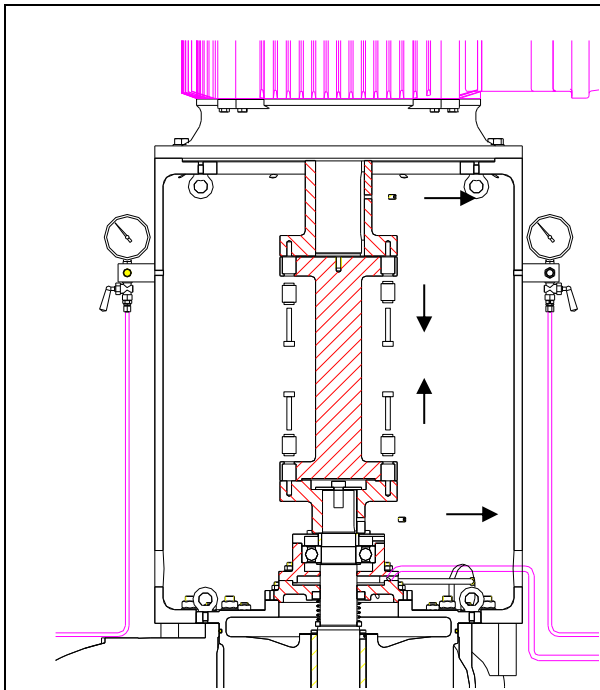

Step 1: Dismantle screw (705) and bushing (704), unscrew (710).

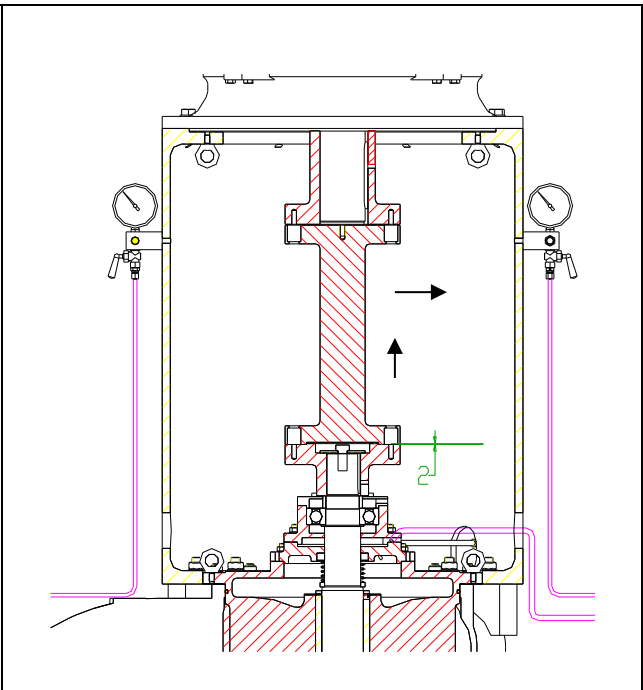

Step 2: Lift spacer shaft (702) 2mm, remove it.

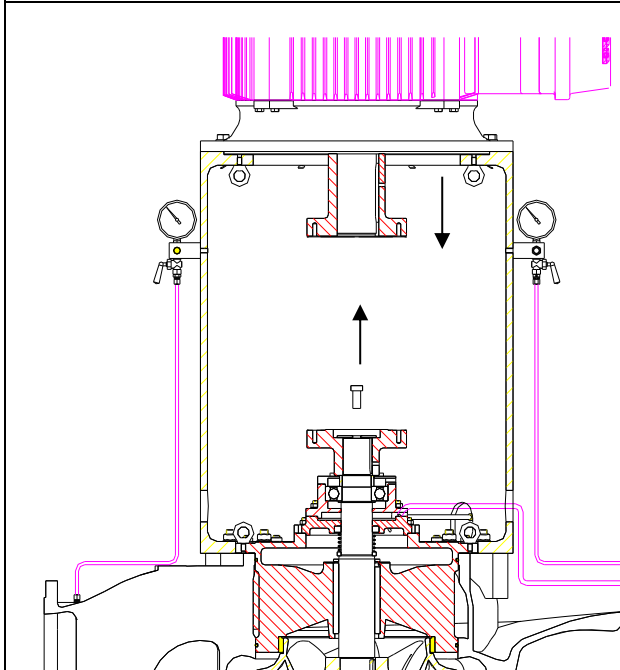

Step 3: Dismantle the pump coupling by unscrewing 708, and take out the key (204), remove the coupling hub (703).

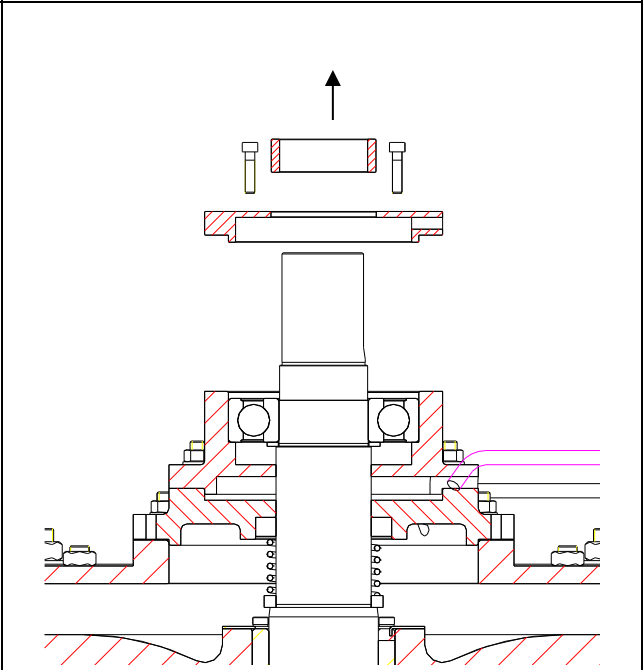

Step 4: Unscrew 911, dismantle bearing cover (304), and take out the position ring (315).

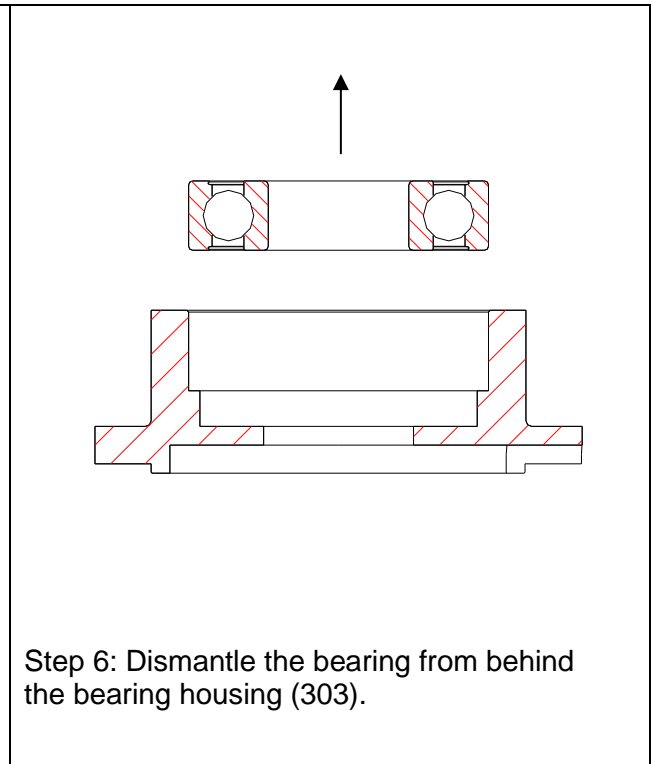
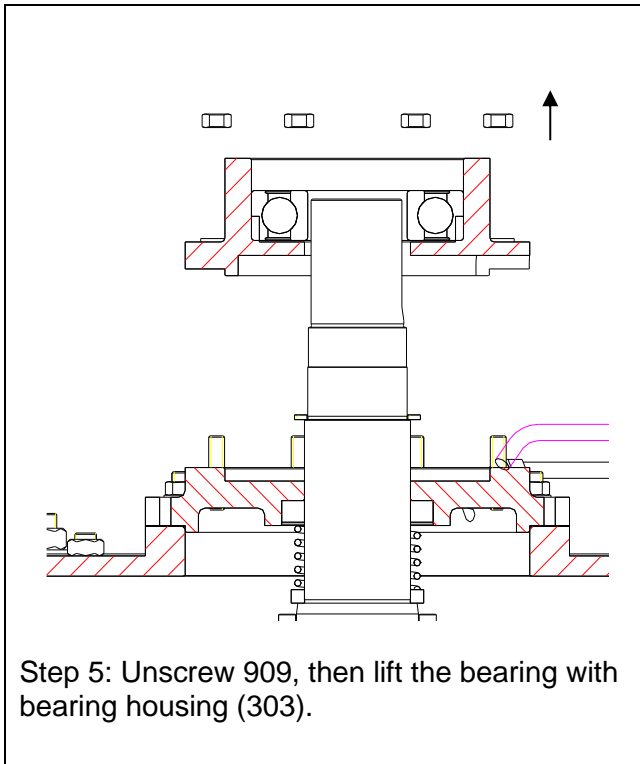

5.2.2 DISMANTLING SHAFT SEAL

First, dismantle the bearing housing as described in paragraph 5.1, then remove the pipes connected to the sealing cover.

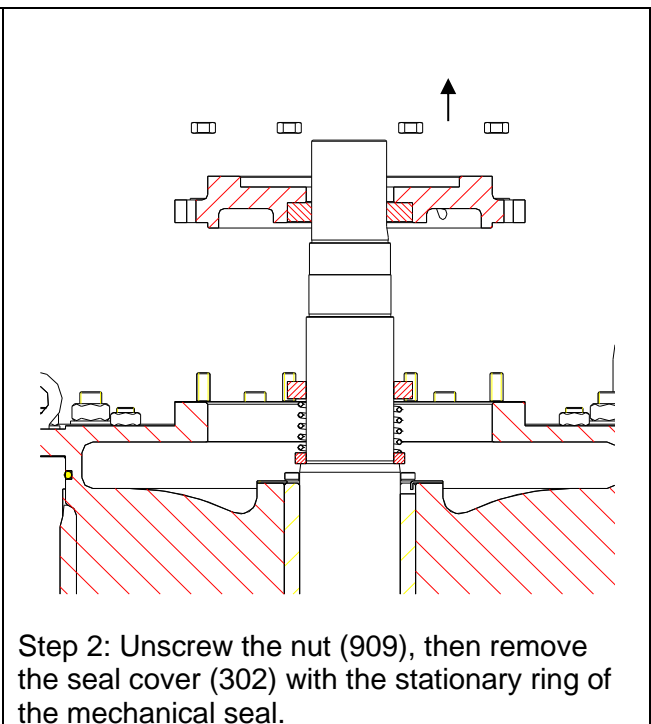
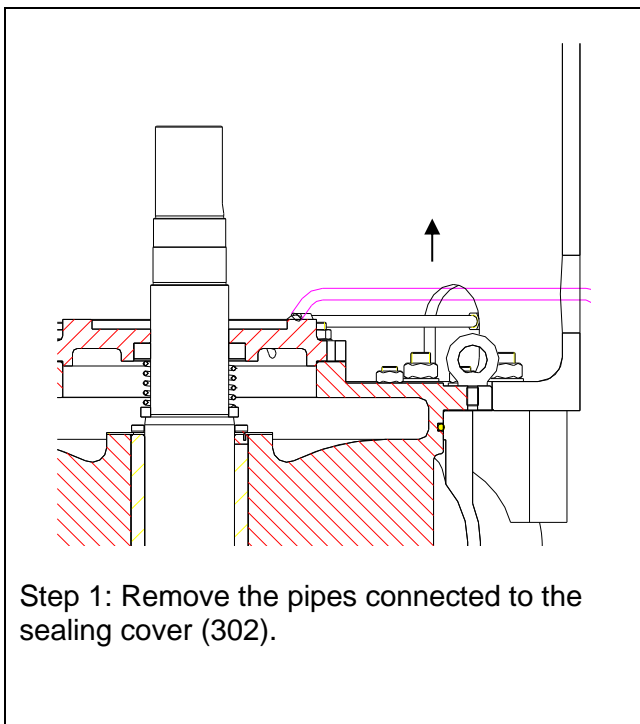

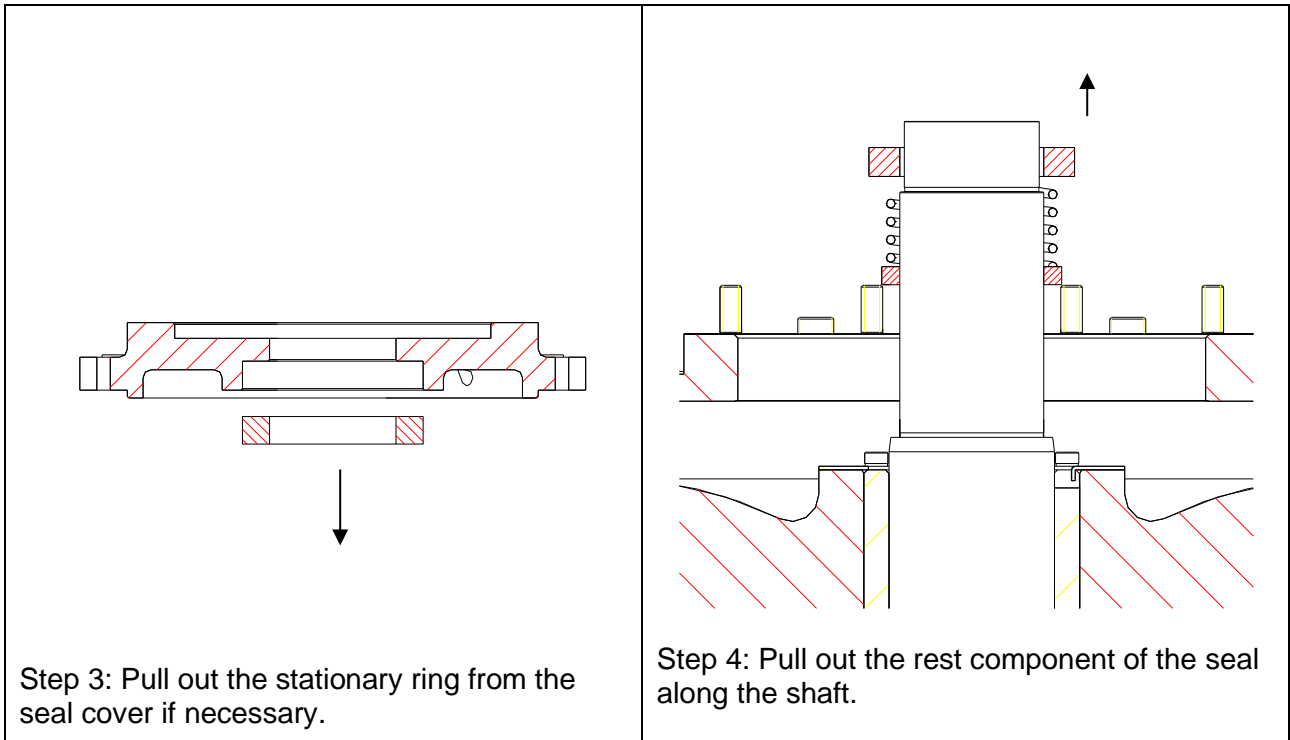

5.2.3 DISMANTLING THE IMPELLER AND REAR COVER

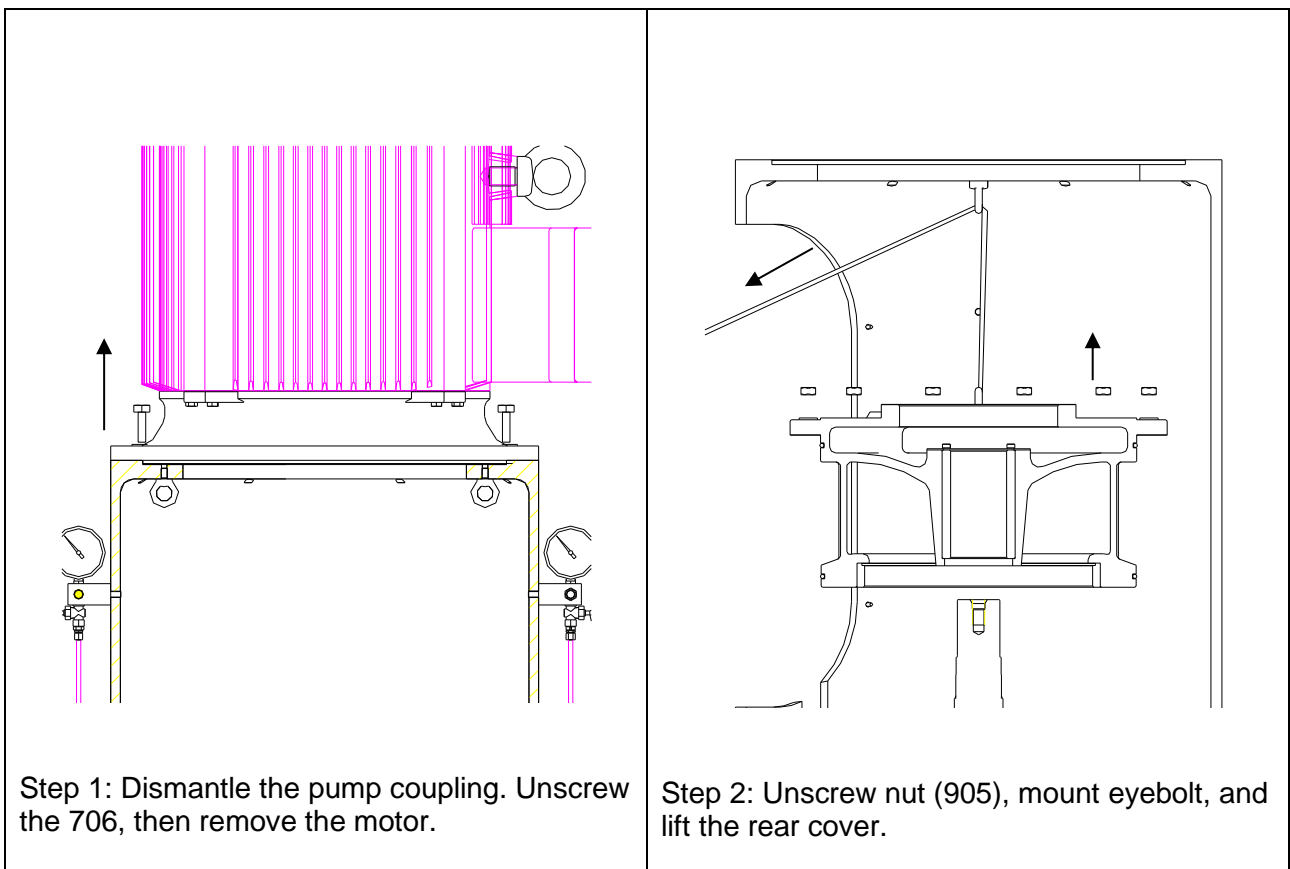

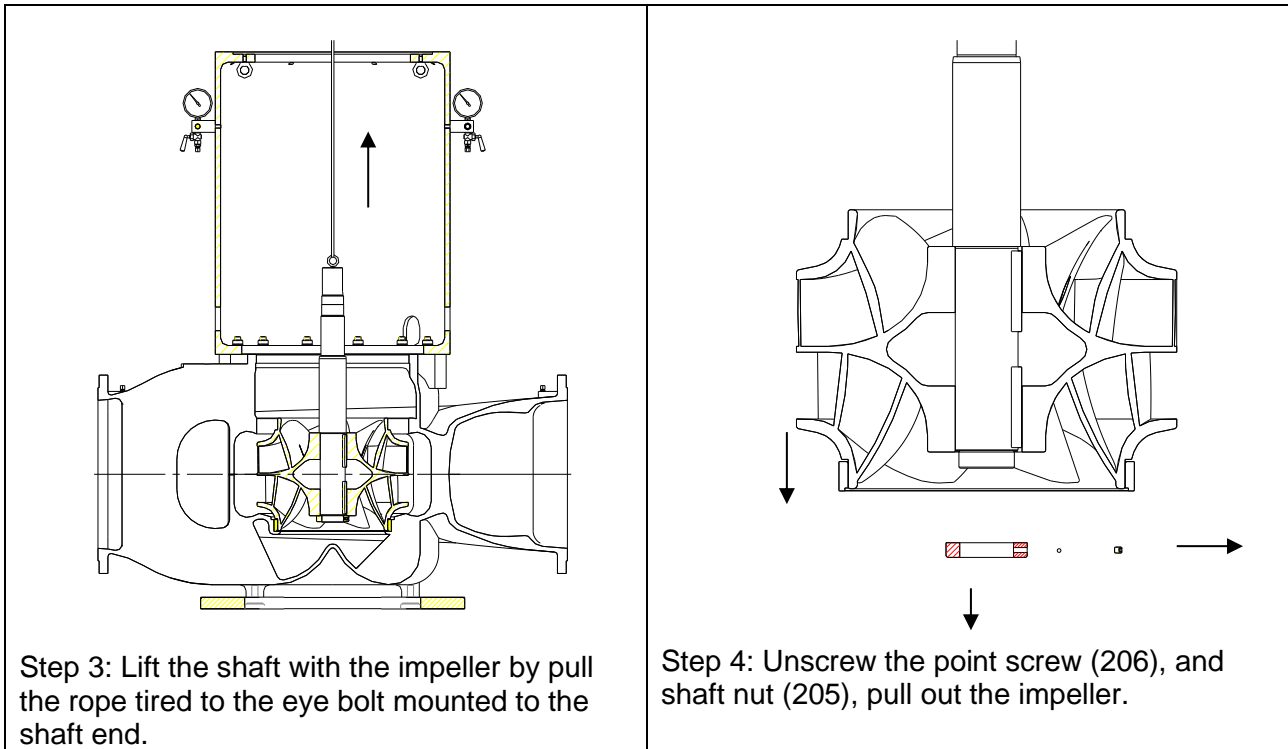

6. ASSEMBLING

It is a reversal of the dismantle process.

7. FROST PROTECTION

Pumps which are not in operation during frost periods are to be drained to avoid frost damage. Please refer to section 11.2 regarding draining of the pump. Alternatively, it is possible to use anti-freeze liquids in normal constructions (add anti-freeze in rear cover top chamber also).

8. DISMANTLING

Before dismantling the pump make sure that it has stopped. Wiring to be dismantled by skilled workmen. Then empty the pump of liquid before it is dismantled from the piping system. If the pump has been pumping dangerous liquids you are to be aware of this and take the necessary safety measures.

If the pump has been pumping hot liquids, take great care that it is drained before it is removed from the piping system.

9. START-UP

A centrifugal pump will not function until it has been filled with liquid between the foot valve and up to somewhat above the impeller.

The liquid also serves as coolant for the shaft seal. In order to protect the shaft seal the pump must not run dry.

ATTENTION

For safety reasons the pump is only allowed to operate against closed discharge valve for a short time (max. 5 minutes and at a max. temperature of 80°C for standard pumps). Otherwise, there is a risk of damage to the pump and, at worst, of a steam explosion. If the pump is not monitored, the installation of a safety device is recommended

9.1 STARTING

Check in the electric motor manual if the bearings in the actual motor shall be lubricated with grease before first start-up.

On pumps not running the shaft shall be rotated (at least 2-3 revolutions) monthly to avoid standstill damage to shaft seal and bearings. If the pump is filled with liquid it can alternatively be started up shortly.

In special applications, it may require more frequent shaft rotation or start-up in order to avoid seizing of the impeller and/or the shaft seal.

In pressurized systems the shaft seal often leaks a bit during standstill – in most cases the leakage stops shortly after the pump is started up.

Before starting the pump check that:

- 1.The shaft can rotate freely without jarring sounds.
- 2.Pump and suction line are filled with liquid.
- 3.For pumps with priming unit: Check that the priming continues until liquid comes out.

The above is important as the liquid serves as coolant for the shaft seal.

4.Start/stop the pump shortly in order to visually check the direction of rotation. If the direction is correct (i.e. clockwise when viewed from above), the pump may be started.

It is not recommended to lead liquid (either one way or the other) through a passively rotating pump, as this could damage the shaft seal.

For the sake of the shaft seal and sliding bearing lifetime, it is recommended to run at least 300 rpm and use max. 1 minute on acceleration from 0 to 300 rpm and max. 1 minute on deceleration from 300 to 0 rpm.

10. SYSTEM BALANCING

It is often difficult to calculate a manometric delivery head in advance. It is, however, decisively important to the quantity of liquid delivered.

A considerably smaller delivery head than expected will increase the quantity of liquid delivered, causing increased power consumption and perhaps cavitation in pump and piping. In the pump the impeller may show signs of heavy erosion caused by cavitation (corrosion) which may at times render an impeller unfit for use in a very short time. Not unusually do similar erosions occur in pipe bends and valves elsewhere in the piping system.

Therefore, after start-up, it is necessary to check either the quantity of liquid delivered or the power consumption of the pump e.g. by measuring the current intensity of the connected motor. Together with a reading of the differential pressure the quantity of water delivered can be determined against the characteristics of the pump.

Should the pump not function as intended, please proceed according to the fault-finding list. Bear in mind, though, that the pump was carefully checked and tested at the factory and that the majority of faults stem from the piping system.

10.1 FAULT-FINDING CHART

FAULT	CAUSE	REMEDY
The pump has no or too low capacity	1. Wrong direction of rotation	Change direction of rotation to clockwise when viewed from above (the direction of the arrow)
	2. Piping system choked	Clean or replace
	3. Pump choked	Clean the pump
	4. Suction line leaks/ Pump takes air	Find leakage, repair the fault, non-return valve not submerged
	5. Suction lift too high	Check data sheet Q/H curve and NPSH or contact DESMI
	6. Pump and piping system wrongly dimensioned	As 5
	7. The pump is not ventilated	Ventilate the pump
The pump uses too much power	1. Counter-pressure too low	Insert orifice plate or check valve/Contact DESMI
	2. The liquid is heavier than water	Contact DESMI
	3. Foreign body in pump	Dismantle the pump, remove the cause
	4. Electric motor is running on 2 phases	Check fuses, cable connection, and cable
The pump makes noise	1. Cavitation in pump	Suction lift too high/ Suction line wrongly dimensioned/Liquid temperature too high

11. INSPECTION AND MAINTENANCE

11.1 INSPECTION DURING OPERATION

It is important to check at regular intervals that:

1. The pump pressure is as prescribed.
2. The pump does not vibrate, make noise or get hot.
3. There is no air in the pump.
4. No liquid is dripping from the drain holes for the shaft seals thus indicating leaks.
5. For pumps with top ball bearing: The vertical gap between pump coupling hub and bearing cover to be more than 1 mm.*

*The nominal gap between pump coupling hub and bearing cover is 2 ± 0.5 mm (not considering local paint layer thickness). If the gap is less than 1 mm the top ball bearing might be worn out.

If one of the above points is not satisfactory, stop the pump and repair the fault.

On pumps with top ball bearing (i.e. /-G-U or /-B-U design) the drain hole at the mechanical shaft seal must be inspected regularly (see drawing example below). Clean the drain hole as needed. If the drain hole clogs up, leaking liquid and/or vapors from the shaft seal can be forced up into the bearing unit, which can result in a much shorter bearing life than normal.

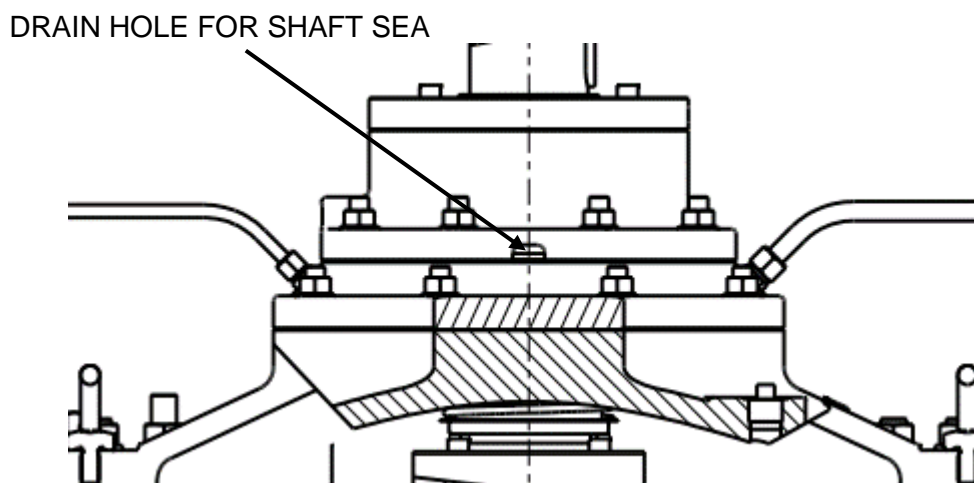

Inspection and maintenance intervals for normal applications:

(half intervals are recommended for a new application – until required intervals can be determined for actual application)

(if daily inspection is not done remote monitoring of pump is recommended – e.g. via temperature sensors on pump bearings)

Inspect (I) or Maintain (M) at the indicated calendar time or run time interval – whichever comes first	Daily	Weekly	Monthly	8000 running hours or 12 months	25000 running hours or 60 months
Shaft seal leakage (normally less than 0.5 mL/hour (~10 drops/hour) – if more than 5 mL/hour shaft seal replacement is recommended	I				
Motor ampere and/or power consumption within normal range	I				

Unusual noise	I				
Unusual vibration (normally less than 2.8 mm/s from pump itself – and less than 7 mm/s incl. external excited vibrations)	I				
Pressure gauge readings to be within normal range (i.e. keep flow within 70 to 120% of BEP flow if allowed by NPSHa <> NPSHr – see note below)	I				
Unusual bearing temperatures (normally less than 85°C)		I			
Check (clean if required) drain hole for shaft seal			I (M)		
Pumps not running: Rotate pump shaft 2 to 3 revolutions or start shortly (if pump is filled with liquid)			M		
Regrease pump bearing (if any) and/or motor bearings	Refer to section 11.4 and motor manual (if motor bearings are re-greaseable)				
Spacer coupling elastomer(s)				I	
Replace mechanical shaft seal and V-ring					M
Replace pump bearings					M
Replace Spacer coupling elastomer(s)					M

Note: Operation outside 70 to 120% of BEP flow reduce the pump life (incl. shaft seal and pump bearings) significantly.

11.2 DRAINING THE PUMP

When the piping system has been drained, note that there is still liquid left in the pump. Most of the liquid can be drained by dismantling the pipe plug (505) at the bottom. If further drainage is required (e.g. for frost protection) then for DSL150, DSL250, DSL300 and DSL350 the liquid trapped in the rear cover top chamber can be removed by dismantling the plug in the top of the rear cover – and then use a pipe or hose for sucking up the liquid.

11.3 INSPECTION

Inspect the shaft seal for leaks at regular intervals.

- Before any inspection of the pump without guard check that the unit cannot be started unintentionally.
- The system is to be without pressure and drained of liquid.
- The repairman must be familiar with the liquid which has been pumped as well as the safety measures he is to take when handling the liquid.

When the pump has been dismantled check the following parts for wear and damage:

- Sealing ring/impeller : Wear=max. 1.5 mm diameter difference.
- Shaft seal : Check seat for flatness and cracks.
Check rubber parts for elasticity.
- Ball bearing : Slackness or noise.
- Sliding bearing/shaft : Wear=max. 0.7 mm diameter difference.
- Coupling parts : Screws and coupling bushes, see paragraph 5.2.
- Pipes from pump casing suction and pressure side to shaft seal: Cleanness.

11.4 LUBRICATING BEARINGS

For pumps with top ball bearing the re-greasing intervals are given below.

The lubrication procedure is as follows during assembly / maintenance:

1. Dismantle the bearing as described in paragraph 5.1.
2. Remove the old grease from bearing and bearing housing.
3. If the bearing has just been cleaned or if it is a new bearing, fill the bearing with grease.
Also fill the bearing housing chamber below the bearing with grease (see drawing below).

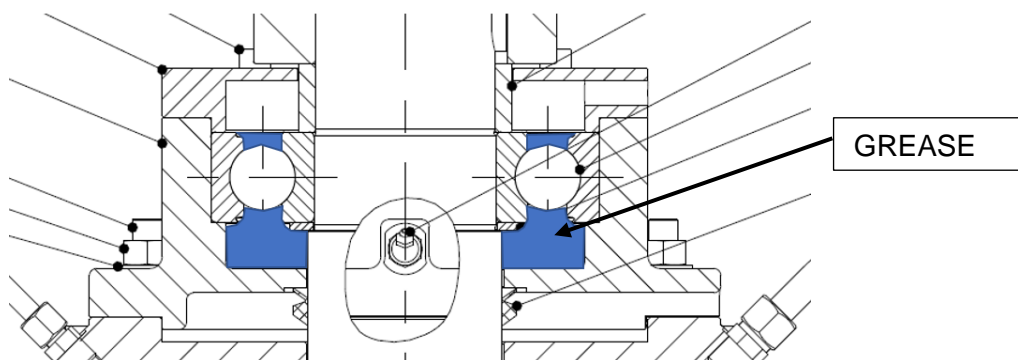

4. Use a recommended lithium-based grease, see the table below.

Recommended types of grease:

EXXON	Beacon ep 2 Moly
BP	Energrease LS EP 2
Shell	Gadus S5 V100 2
Mobil	Mobil lux grease EP 2
Castrol	Spheerol AP 2 or AP 3
Texaco	Multifak EP 2
Q8	Rembrandt EP 2 or Rubens EM 2
Statoil	UniWay Li 62

DESMI use SKF LGHP2 as standard.

Re-grease the top ball bearing of DSL pumps refer to below table and notes:

Pump	Interval	Quantity
DSL150-265 DSL250-310 DSL250-360 DSL300-320 DSL300-495 DSL350-460 DSL450-490 DSL500-490 DSL500-515	<p>The intervals between the lubrication of the bearings depend on the number of revolutions:</p> <p>a. Pump with 4-pole motor: 5000 hours b. Pump with 6-pole motor: 6000 hours c. Pump with 8-pole motor: 7000 hours</p>	30 g

Vibration levels higher than 7 mm/s at pump bearing are considered damaging and will normally result in significantly shorter grease and/or bearing life – especially for pumps not running. Hence shorter re-greasing intervals might be required for pumps installed where external excited vibration levels can be higher than 7 mm/s.

Note that relubrication can cause a (usually temporary) bearing temperature rise of up to approx. 20°C - especially by mixing different types of grease and / or by overlubricating the bearing.

Grease used for relubrication must be compatible with the grease in the bearing unit.

The slide bearing in the pump is lubricated and cooled by the liquid pumped via the pressure side of the pump.

12. REPAIRS

12.1 ORDERING SPARE PARTS

When ordering spare parts please always state pump type and serial No. See the name plate of the pump and the spare parts drawing with item Nos. See assembly drawing.

13. OPERATING DATA

Type	Max speed Rpm	Max. permissible working pressure (GG20 and RG5) bar	Max. permissible working pressure (NiAlBz) bar	Max. permissible working pressure (ductile iron GGG40) bar
DSL150-265	3600	16	24	25
DSL 250-310	2100	6	9	16 (spec. casing)
DSL 250-360	2000	-	10	10
DSL 300-320	1800	6	9	25 (spec. casing)
DSL 300-430	2000	-	13	13
DSL 300-495	1800	-	16	16
DSL 350-460	1800	-	13	16
DSL 400-460	1800	-	8	16 (spec. casing)
DSL 400-498	1400	12	18	25
DSL 450-490	1180	-	8	8
DSL 500-490	1200	5	7.5	7.5
DSL 500-515	1200	6	9	9

The above-mentioned max. working pressure is **NOT** valid for pumps approved by a classification society. Pumps approved by classification societies have been pressure tested according to the requirements of these societies, i.e. a test pressure of 1.5 x the permissible working pressure. The test pressure is stated in the test certificate and stamped into the discharge flange of the pump.

14. EU & UK DECLARATION OF CONFORMITY

DESMI Pumping Technology A/S, hereby declare that our pumps of the type DSL are manufactured in conformity with the following essential safety and health requirements in the COUNCIL DIRECTIVE 2006/42/EC on machines, Annex 1.

The following harmonized standards have been used:

EN/ISO 13857:2019	Safety of machinery. Safety distances to prevent danger zones being reached by the upper limbs
EN 809:1998 + A1:2009	Pumps and pump units for liquids – Common safety requirements
EN12162:2001+A1:2009	Liquid pumps – Safety requirements – Procedure for hydrostatic testing
EN 60204-1:2006/A1:2009	Safety of machinery – Electrical equipment of machines (item 4, General requirements)
Ecodesign Directive (2009/125/EC).	Water pumps: Commission Regulation No 547/2012. Applies only to water pumps marked with the minimum efficiency index MEI. See pump nameplate.

Pumps delivered by us connected with prime movers are CE-marked and comply with the above requirements.

Pumps delivered by us without prime movers (as partly completed machinery) must only be used when the prime mover and the connection between prime mover and pump comply with the above requirements.

Nørresundby, November 1 2021



Henrik Mørkholt Sørensen
Managing Director

15. INFORMATION RELEVANT FOR DISASSEMBLY OR DISPOSAL AT END-OF-LIFE:

No damage materials are used in DESMI pumps – please refer to DESMI Green Passport (can be sent on request – contact a DESMI sales office) – i.e. common recycling companies can handle the disposal at end-of-life. Alternatively the pump and motor can be returned to DESMI at end-of-life for safe recycling.

16. ASSEMBLY DRAWING

16.1 DSL150-265/-G

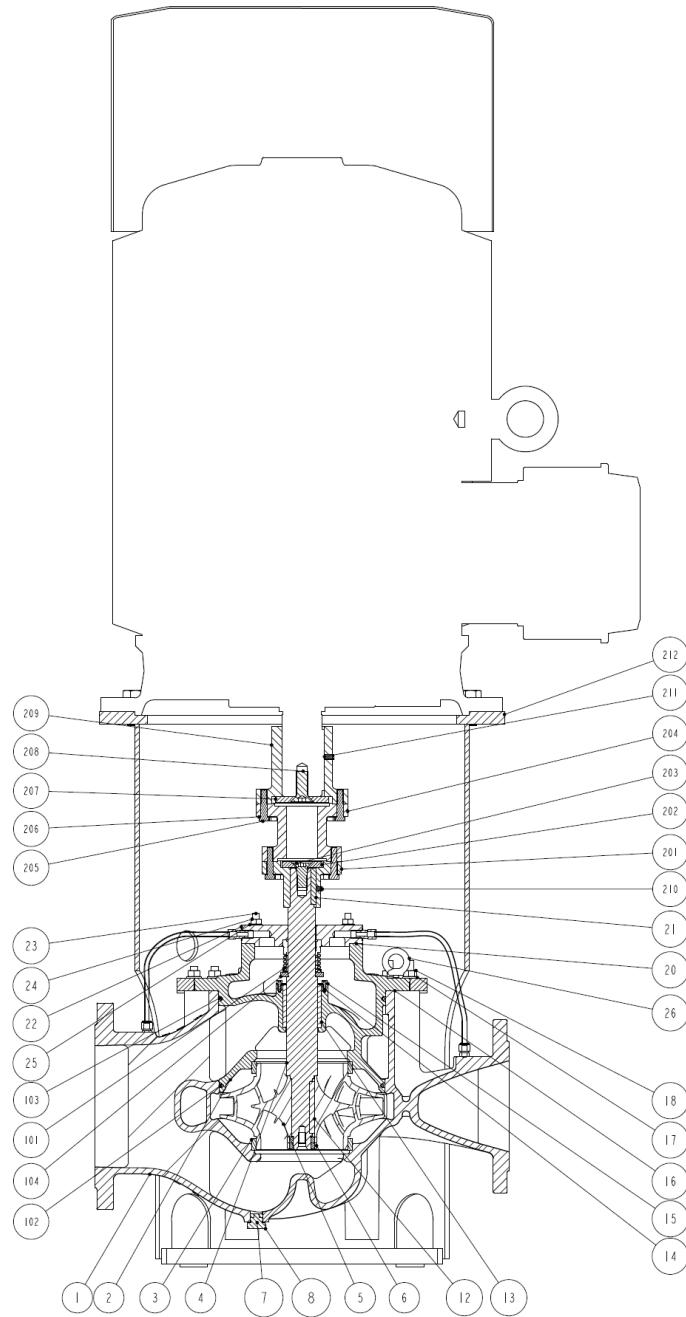

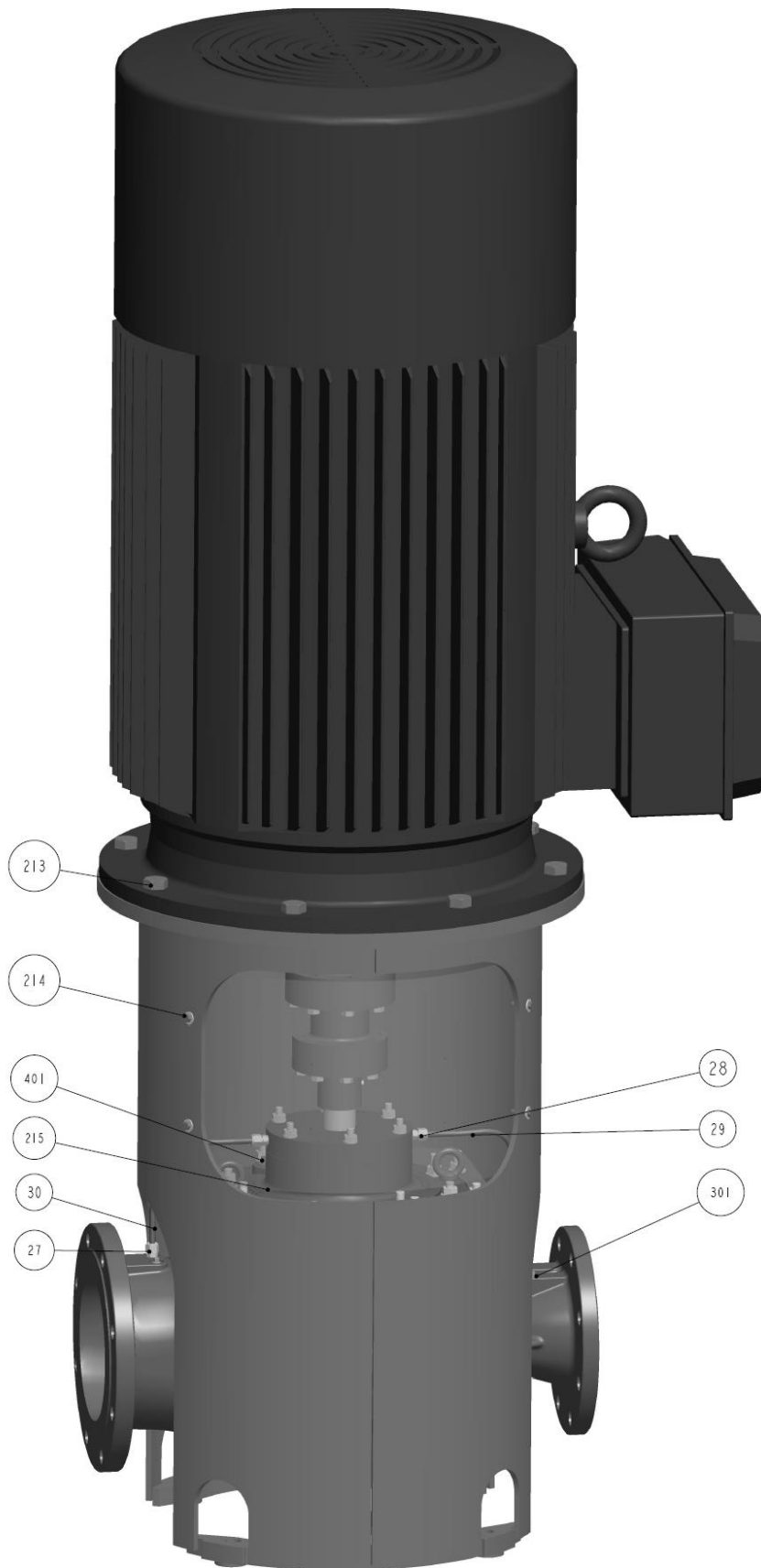

Pos.	Designation	Pos.	Designation
1	Pump Casing	27	Fitting
2	Rear Cover	28	Fitting
3	Seal Ring	29	Tube
4	Shaft	30	Tube
5	Impeller	101	Mechanical Shaft Seal
6	Shaft Nut	102	O-ring
7	Sealing Washer	103	O-ring
8	Plug	104	Support Ring
9	Base Plate	201	Coupling
10	Lock Disc	202	Plate
11	Set Screw	203	Screw
12	Key	204	Coupling
13	Sliding Bearing	205	Screw
14	Allen Screw	206	Washer
15	Lock Plate	207	Plate
16	Gasket	208	Screw
17	Washer	209	Coupling
18	Nut	210	Pointed Screw
19	Stud	211	Pointed Screw
20	Gasket	212	Motor Bracket
21	Key	213	Set Screw
22	Seal Cover	214	Set Screw & Washer
23	Stud	215	Guard
24	Nut	301	Plug
25	Washer	401	Plug
26	Eye Bolt		

16.2 DSL250-310/-G AND DSL250-360/-G

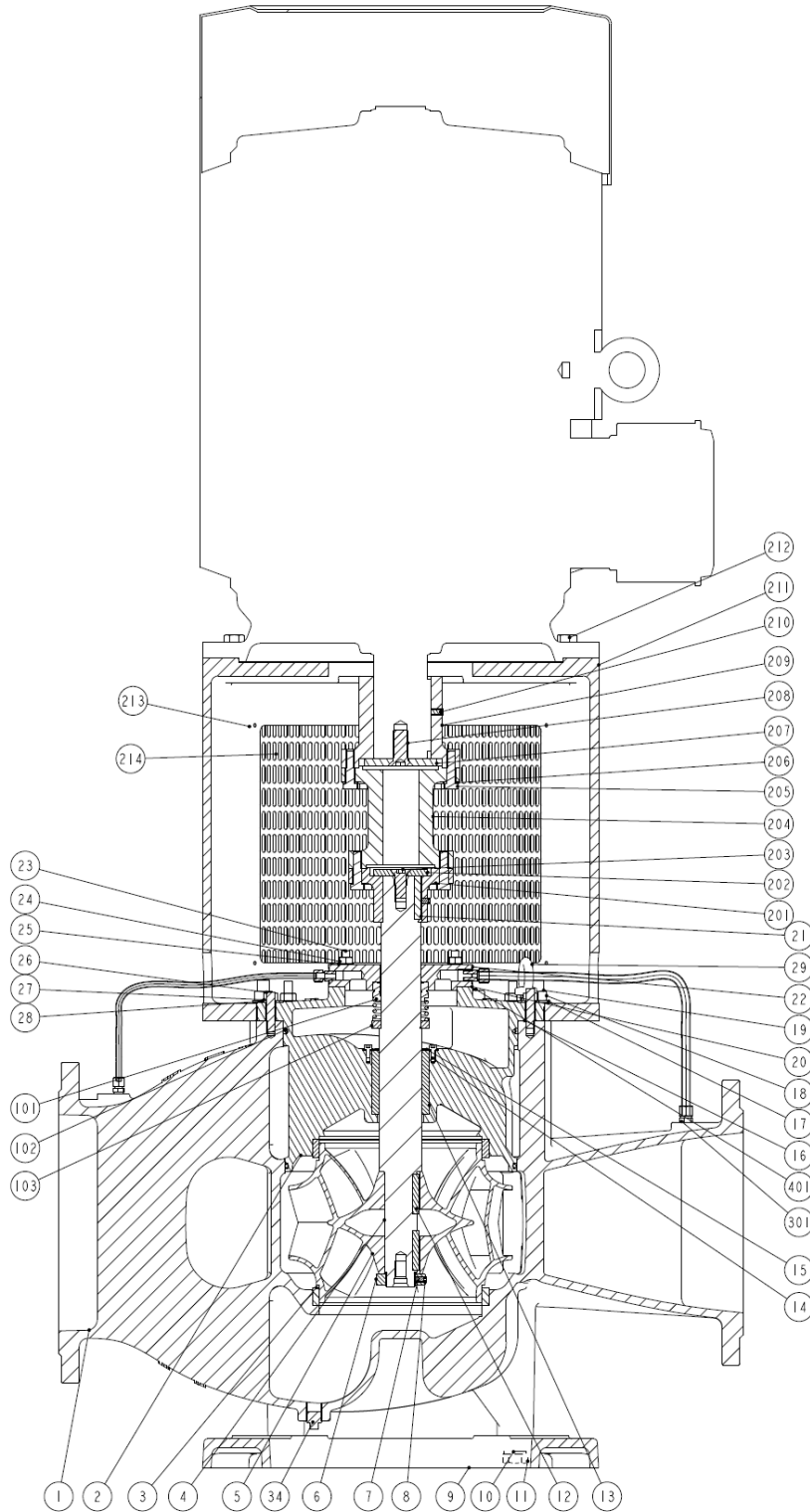

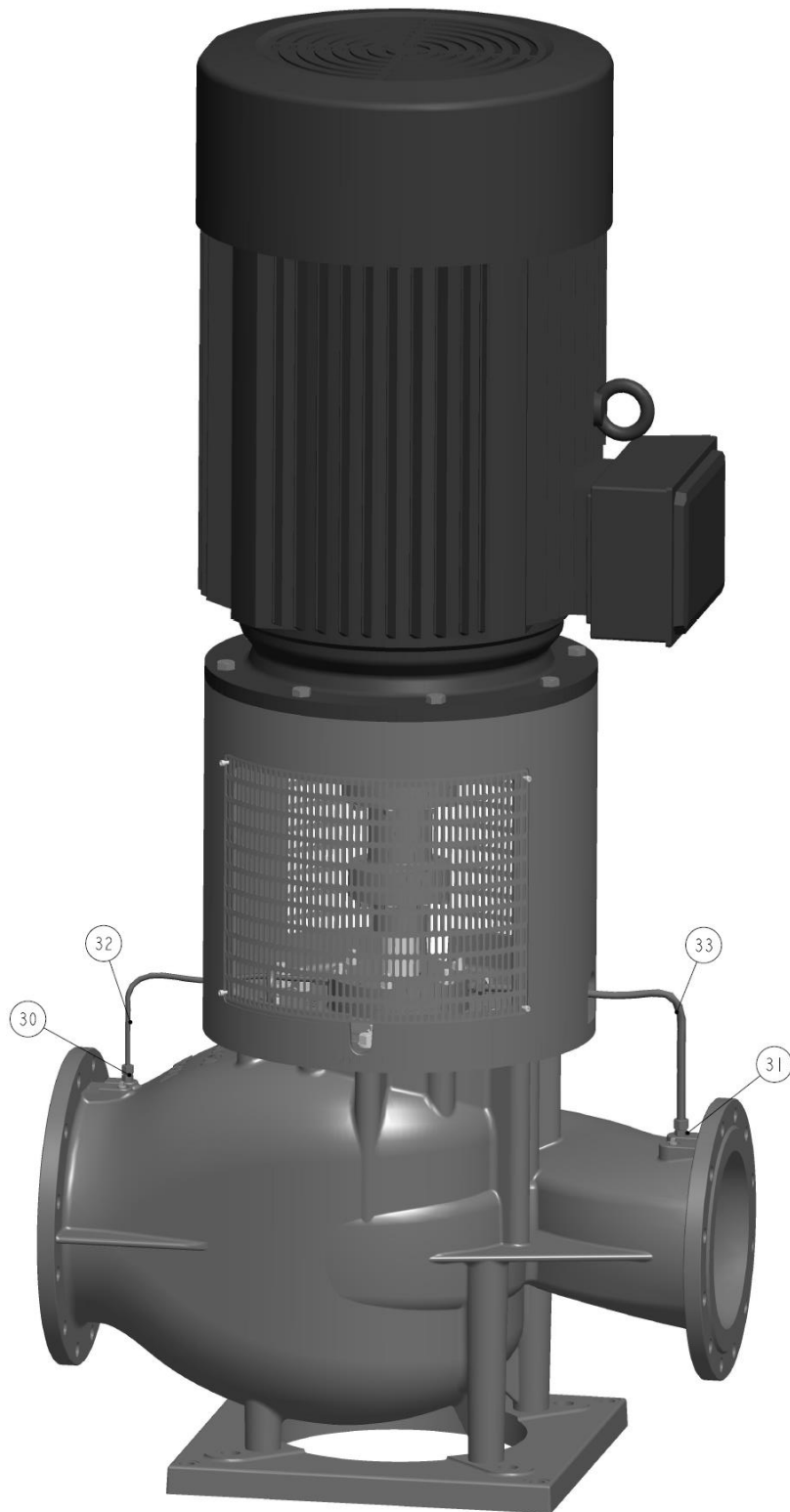

Pos.	Designation	Pos.	Designation
1	Pump Casing	28	Washer
2	Rear Cover	29	Eye Bolt
3	Seal ring	30	Nipple
4	Shaft	31	Nipple
5	Impeller	32	Tube
6	Shaft Nut	33	Tube
7	Plastic Ball	34	Plug
8	Pointed screw	101	Mechanical Shaft Seal
9	Base Plate	102	O-ring
10	Lock Disc	103	Support Ring
11	Set Screw	201	Coupling
12	Key	202	Plate
13	Sliding Bearing	203	Screw
14	Allen Screw	204	Coupling
15	Lock Plate	205	Screw
16	Gasket	206	Washer
17	Washer	207	Plate
18	Nut	208	Screw
19	Stud	209	Coupling
20	Gasket	210	Pointed Screw
21	Key	211	Motor Bracket
22	Seal Cover	212	Set Screw
23	Stud	213	Bolt
24	Nut	214	Guard
25	Washer	301	Plug
26	Stud	401	Plug
27	Nut		

16.3 DSL300-320/-G

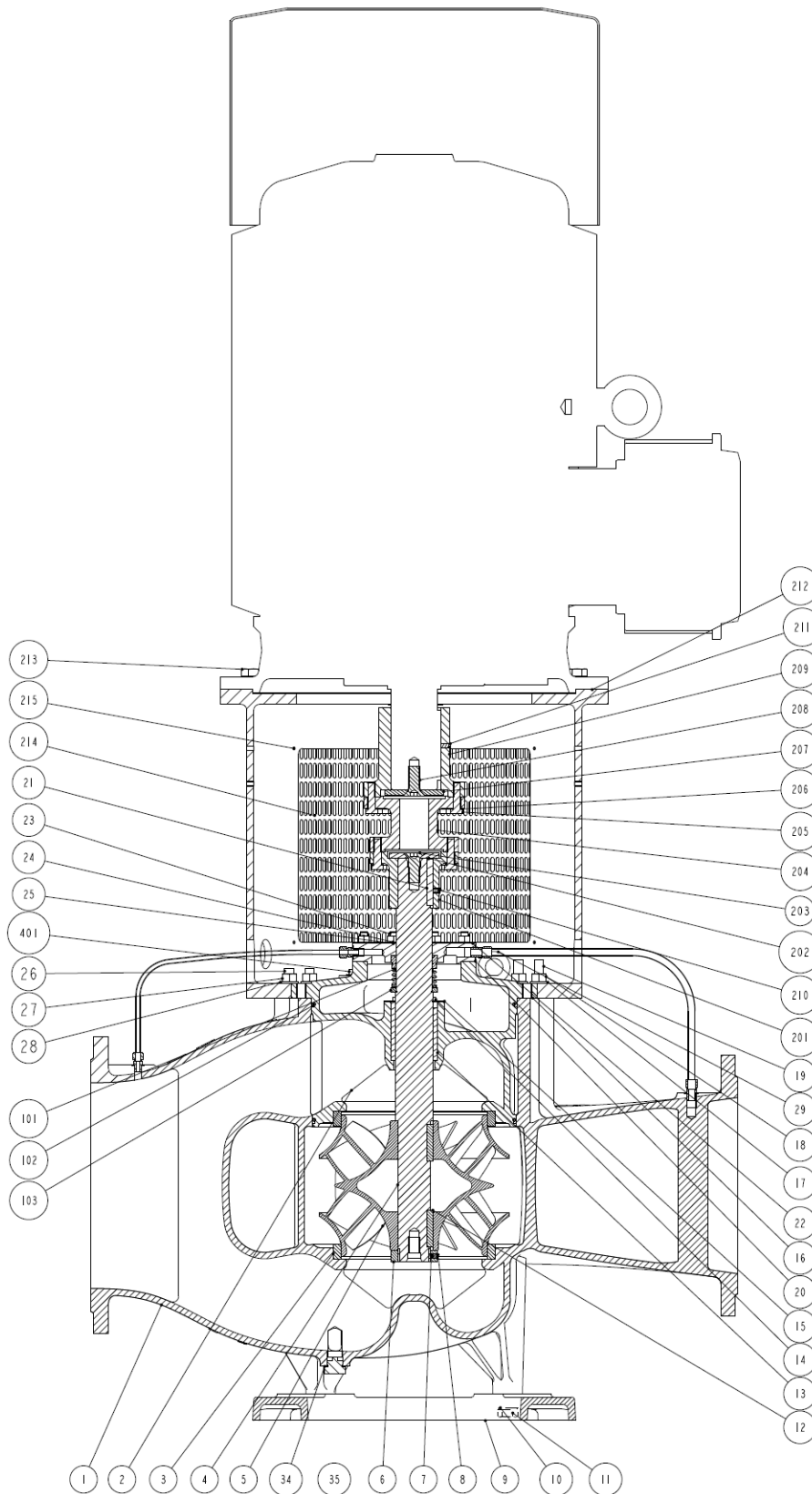

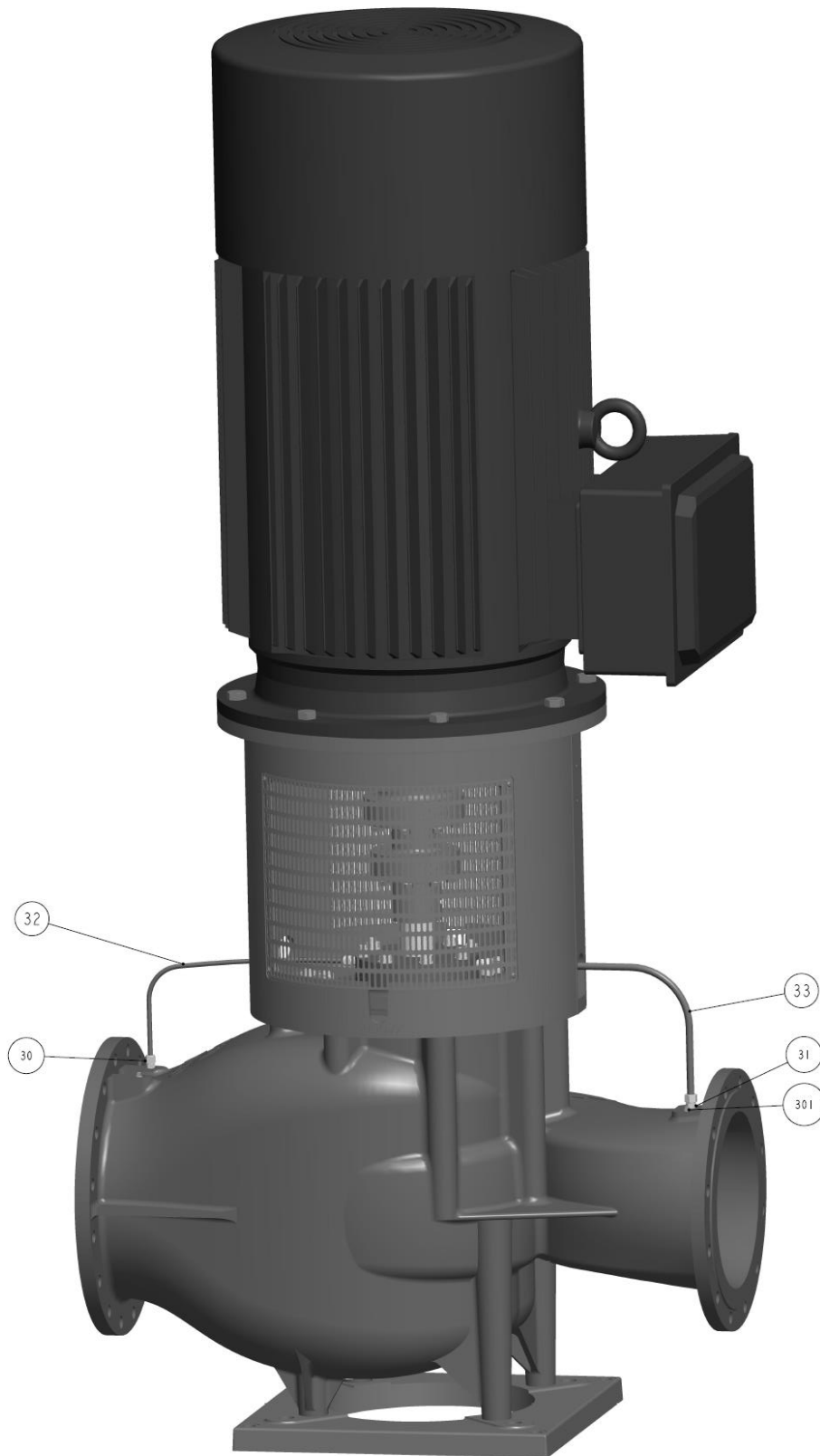

Pos.	Designation	Pos.	Designation
1	Pump Casing	29	Eye Bolt
2	Rear Cover	30	Nipple
3	Seal ring	31	Nipple
4	Shaft	32	Tube
5	Impeller	33	Tube
6	Shaft Nut	34	Washer
7	Plastic Ball	35	Plug
8	Pointed screw	101	Mechanical Shaft Seal
9	Base Plate	102	O-ring
10	Lock Disc	103	Support Ring
11	Set Screw	201	Coupling
12	Key	202	Plate
13	Sliding Bearing	203	Screw
14	Allen Screw	204	Coupling
15	Lock Plate	205	Screw
16	Gasket	206	Washer
17	Washer	207	Plate
18	Nut	208	Screw
19	Stud	209	Coupling
20	Gasket	210	Pointed Screw
21	Key	211	Pointed Screw
22	Seal Cover	212	Motor Bracket
23	Stud	213	Set Screw
24	Nut	214	Guard
25	Washer	215	Screw
26	Stud	301	Plug
27	Nut	401	Plug
28	Washer		

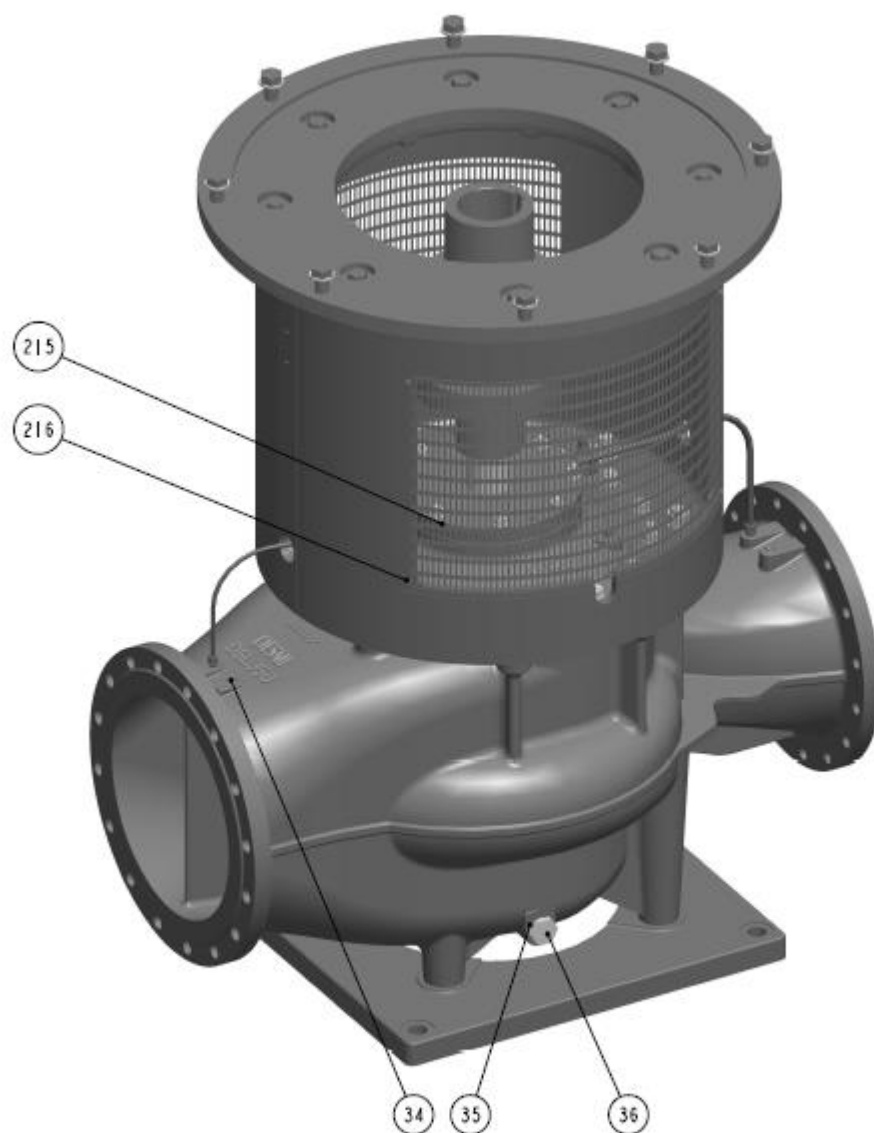

Pos.	Designation	Pos.	Designation
1	Pump Casing	29	Eye bolt
2	Rear Cover	30	Nipple
3	Seal Ring	31	Nipple
4	Shaft	32	Tube
5	Impeller	33	Tube
6	Shaft Nut	34	Plug
7	Plastic Ball	35	Sealing Washer
8	Pointed Screw	36	Plug
9	Base Plate	101	Mechanical Shaft Seal
10	Lock Disc	102	O-Ring
11	Set Screw	103	Support Ring
12	Key	201	Coupling
13	Sliding Bearing	202	Plate
14	Allen Screw	203	Screw
15	Lock Plate	204	Coupling
16	Gasket	205	Screw
17	Washer	206	Washer
18	Nut	207	Plate
19	Stud	208	Screw
20	Gasket	209	Coupling
21	Key	210	Pointed Screw
22	Seal cover	211	Pointed Screw
23	Stud	212	Motor Bracket
24	Nut	213	Washer
25	Washer	214	Screw
26	Stud	215	Guard
27	Nut	216	Set Screw
28	Washer		

16.5 DSL400-498/-G

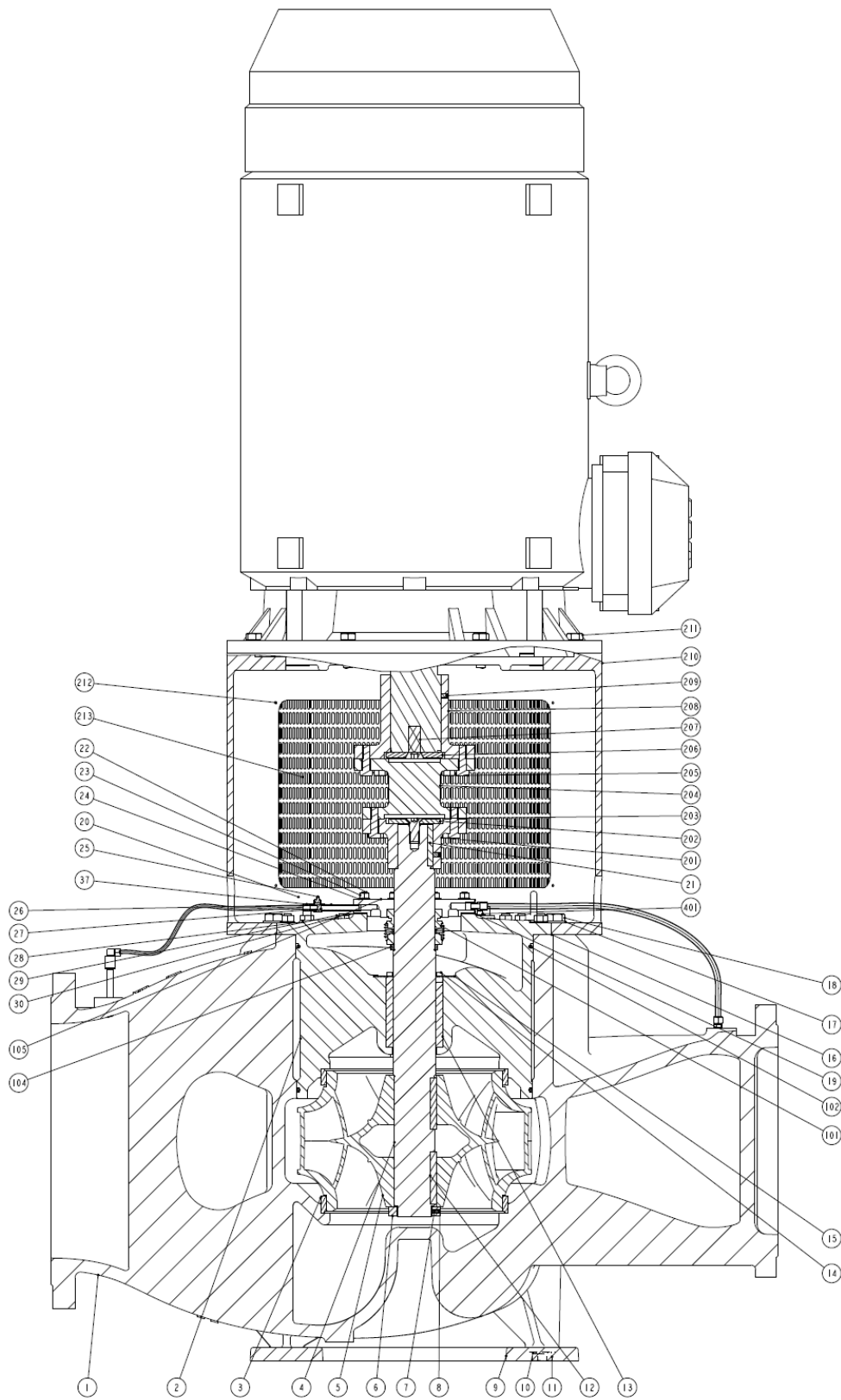

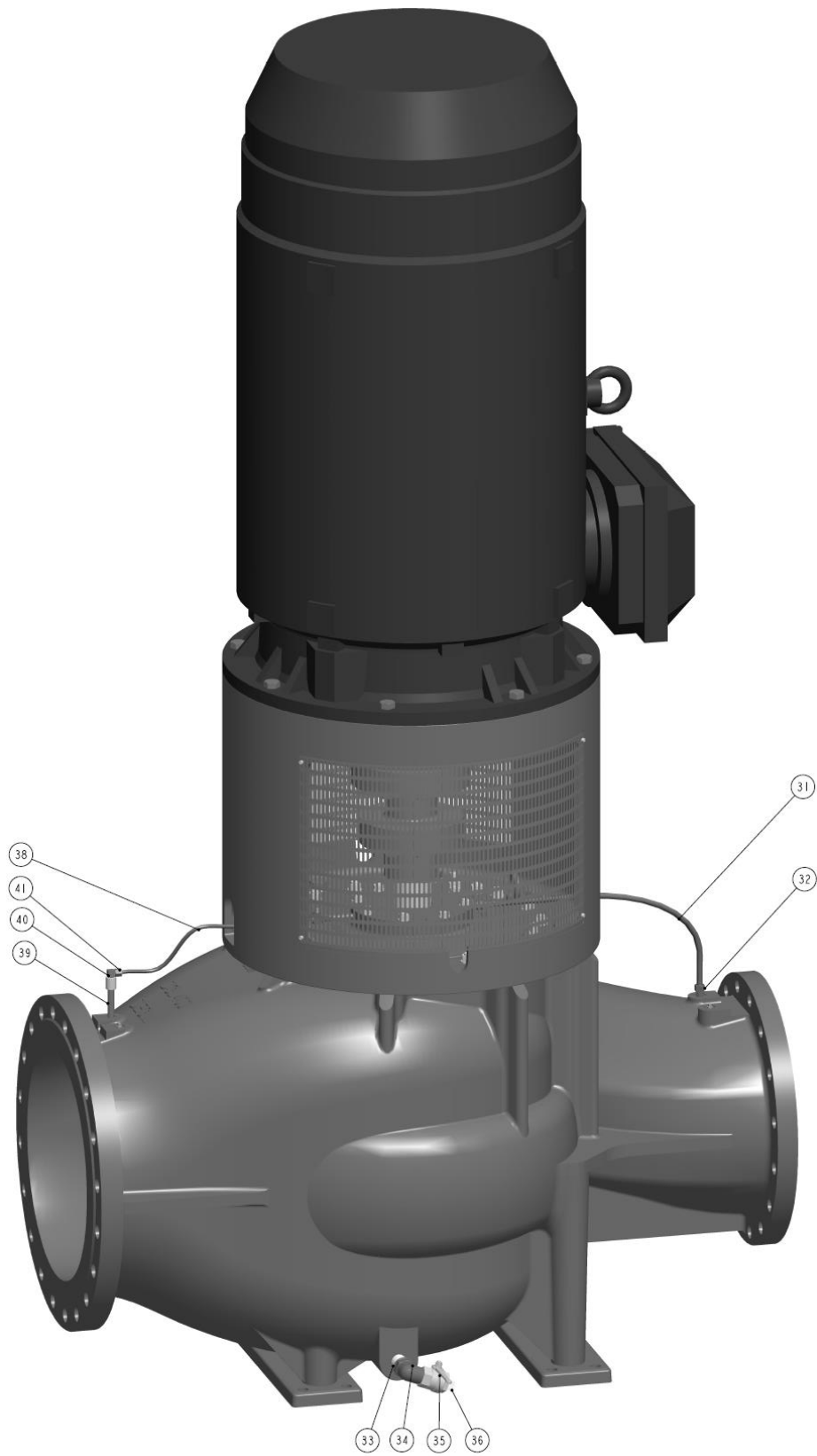

Pos.	Designation	Pos.	Designation
1	Pump Casing	31	Tube
2	Rear Cover	32	Nipple
3	Seal Ring	33	Nipple
4	Shaft	34	Elbow
5	Impeller	35	Ball Valve
6	Shaft Nut	36	Plug
7	Plastic Ball	37	Nipple
8	Pointed Screw	38	Tube
9	Base Plate	39	Nipple
10	Lock Disc	40	Sleeve
11	Set Screw	41	Male Elbow
12	Key	101	Mechanical Shaft Seal
13	Sliding Bearing	102	O-Ring
14	Allen Screw	104	Stop Collar
15	Lock Plate	105	Seal Cover
16	Gasket	201	Coupling
17	Washer	202	Plate
18	Set Screw	203	Screw
19	Gasket	204	Coupling
20	Eye Bolt	205	Screw
21	Key	206	Plate
22	Stud	207	Screw
23	Nut	208	Coupling
24	Washer	209	Pointed Screw
25	Plug	210	Motor Bracket
26	Nipple	211	Set Screw
27	Tee	212	Allen Screw
28	Washer	213	Guard
29	Nut	401	Plug
30	Stud		

16.6 DSL450-490/-G AND DSL500-490/-G

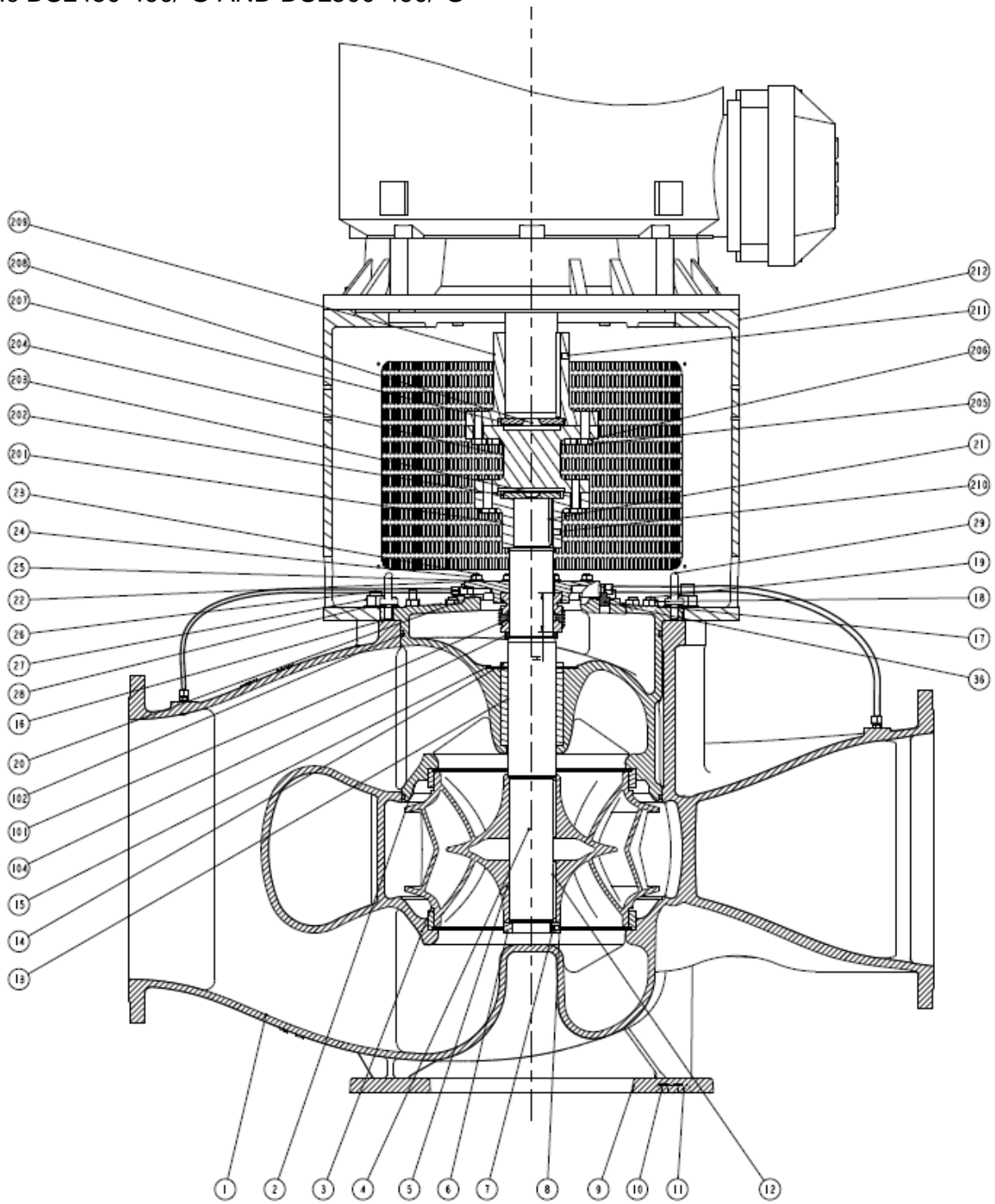

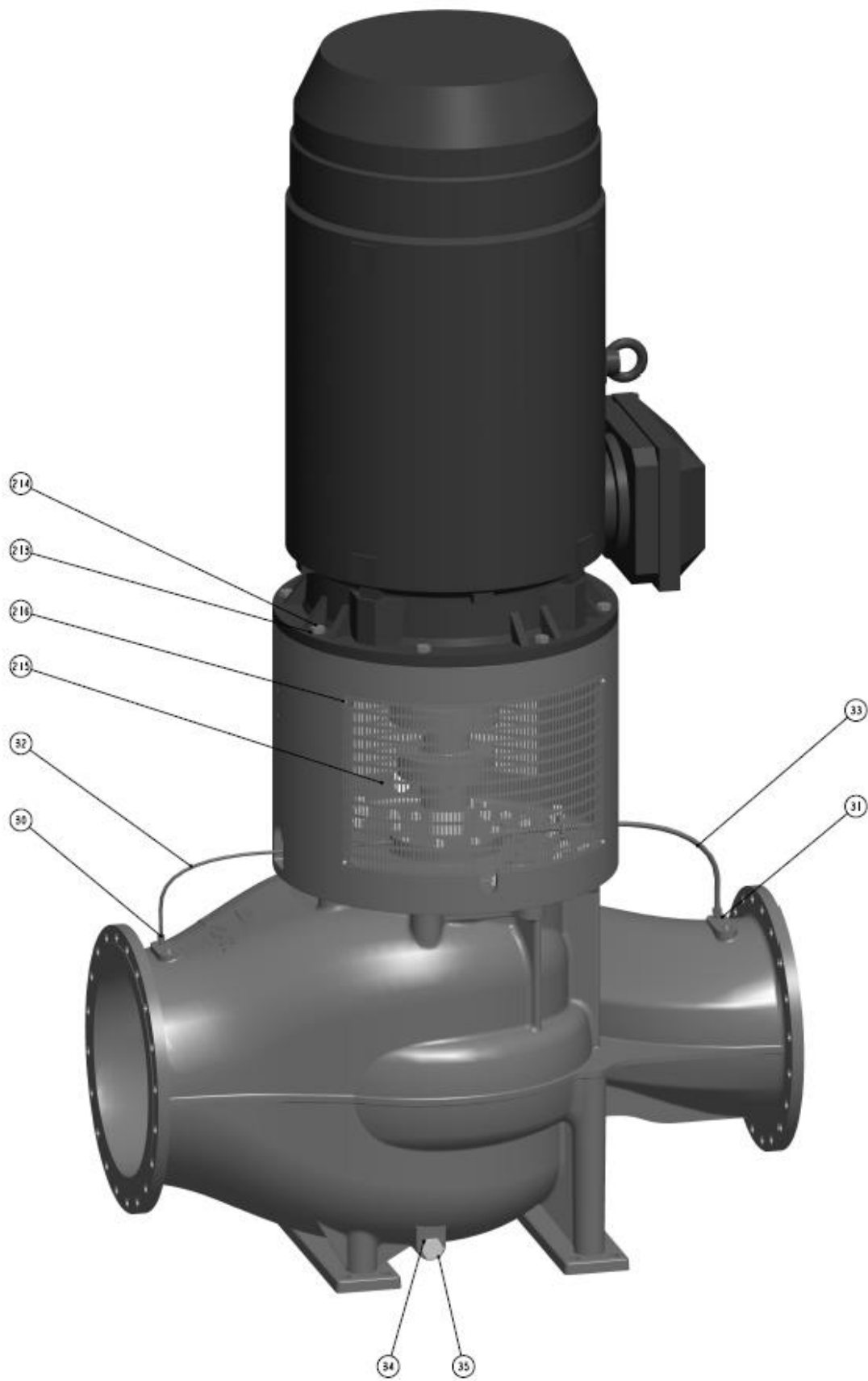

Pos.	Designation	Pos.	Designation
1	Pump Casing	29	Eye bolt
2	Rear Cover	30	Nipple
3	Seal Ring	31	Nipple
4	Shaft	32	Tube
5	Impeller	33	Tube
6	Shaft Nut	34	Sealing Washer
7	Plastic Ball	35	Plug
8	Pointed Screw	36	Plug
9	Base Plate	101	Mechanical Shaft Seal
10	Lock Disc	102	O-Ring
11	Set Screw	104	Support Ring
12	Key	201	Coupling
13	Sliding Bearing	202	Plate
14	Allen Screw	203	Screw
15	Lock Plate	204	Coupling
16	Gasket	205	Screw
17	Washer	206	Washer
18	Nut	207	Plate
19	Stud	208	Screw
20	Gasket	209	Coupling
21	Key	210	Pointed Screw
22	Seal cover	211	Pointed Screw
23	Stud	212	Motor Bracket
24	Nut	213	Washer
25	Washer	214	Screw
26	Stud	215	Guard
27	Nut	216	Set Screw
28	Washer		

16.7 DSL450-490/-G-U

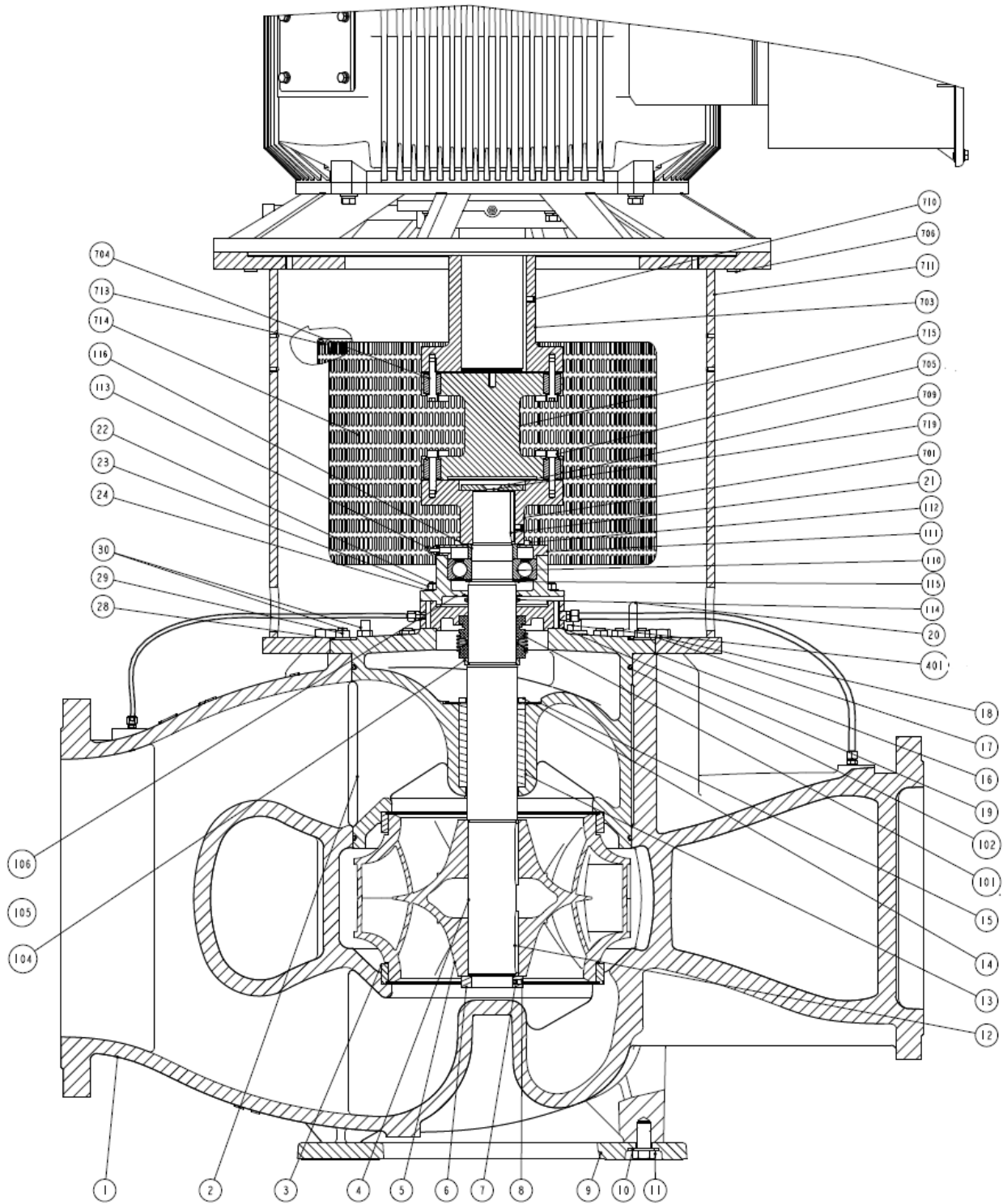

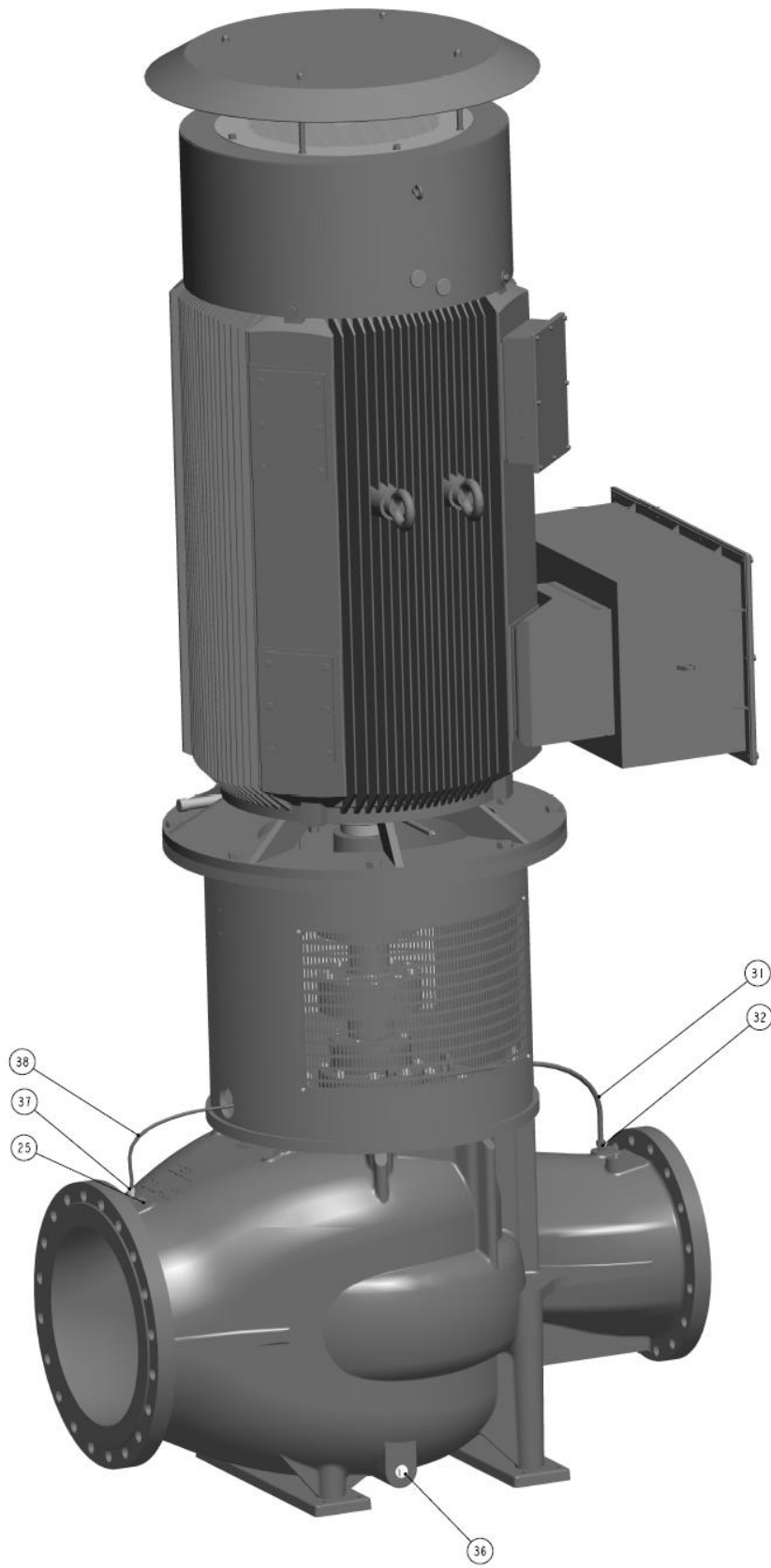

Pos.	Designation	Pos.	Designation
1	Pump Casing	37	Male connector
2	Rear Cover	38	Tube
3	Seal Ring	101	Mechanical seal
4	Shaft	102	O-ring
5	Impeller	104	Support ring
6	Shaft Nut	105	Sealing Cover
7	Plastic Ball	106	Bearing housing
8	Pointed Screw	110	Ball bearing
9	Base Plate	111	Bearing cover
10	Lock Disc	112	Screw
11	Set Screw	113	Grease nipple
12	Key	114	V-ring
13	Sliding Bearing	115	Snap ring
14	Allen Screw	116	Position ring
15	Lock Plate	401	Plug
16	Gasket	701	Pump coupling
17	Washer	703	Motor coupling
18	Set Screw	704	Coupling bush
19	Gasket	705	Allen Screw
20	Eye Bolt	706	Screw
21	Key	707	Washer
22	Stud	709	Thrust plate
23	Nut	710	Point screw
24	Washer	711	Bracket
25	Plug	713	Allen Screw
28	Washer	714	Guard for bracket
29	Nut	715	Spacer coupling
30	Stud	719	Thrust plate
31	Tube		
32	Nipple		
36	Plug		

16.8 DSL500-515/B-U, DSL300-320/-B-U

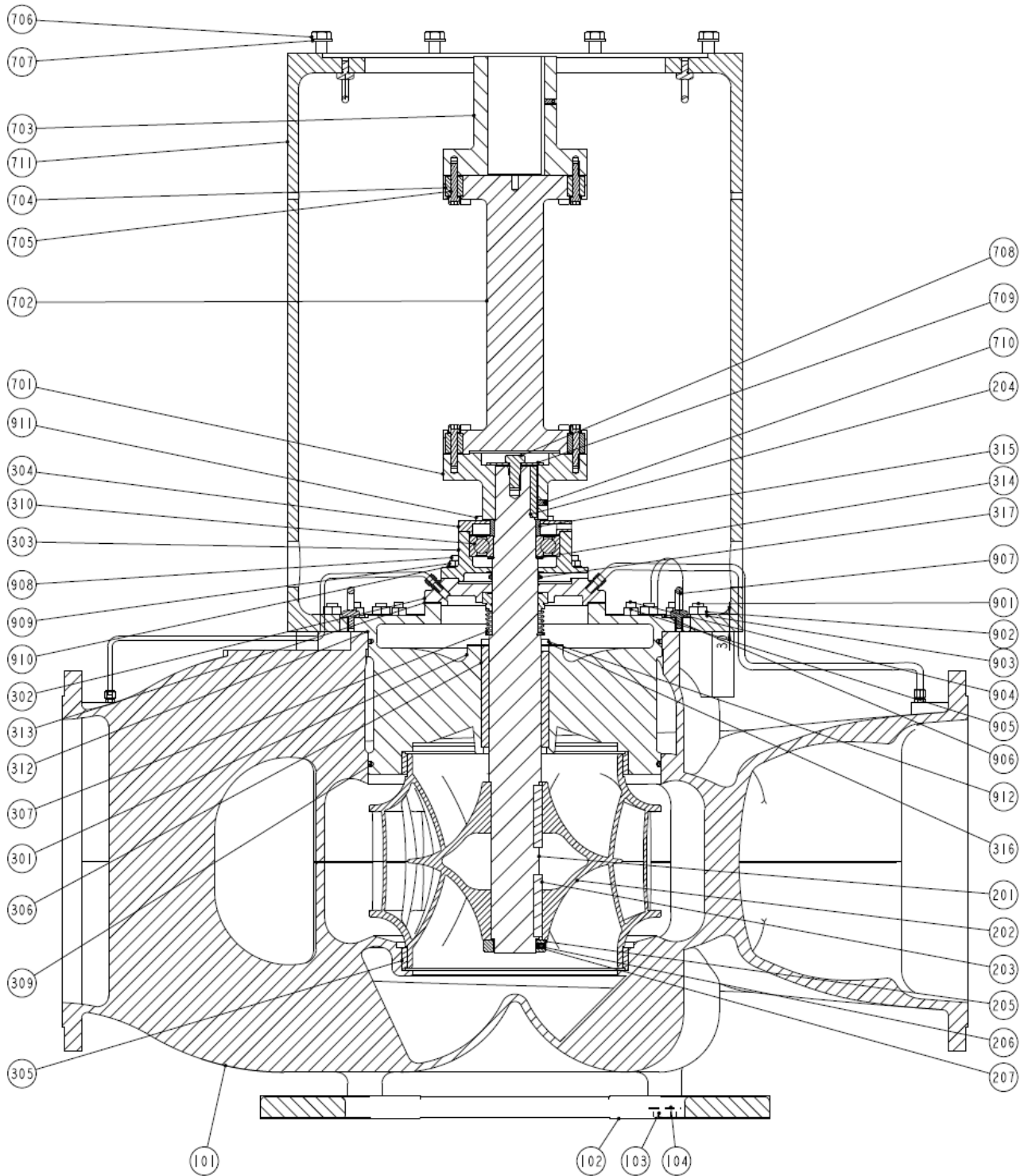

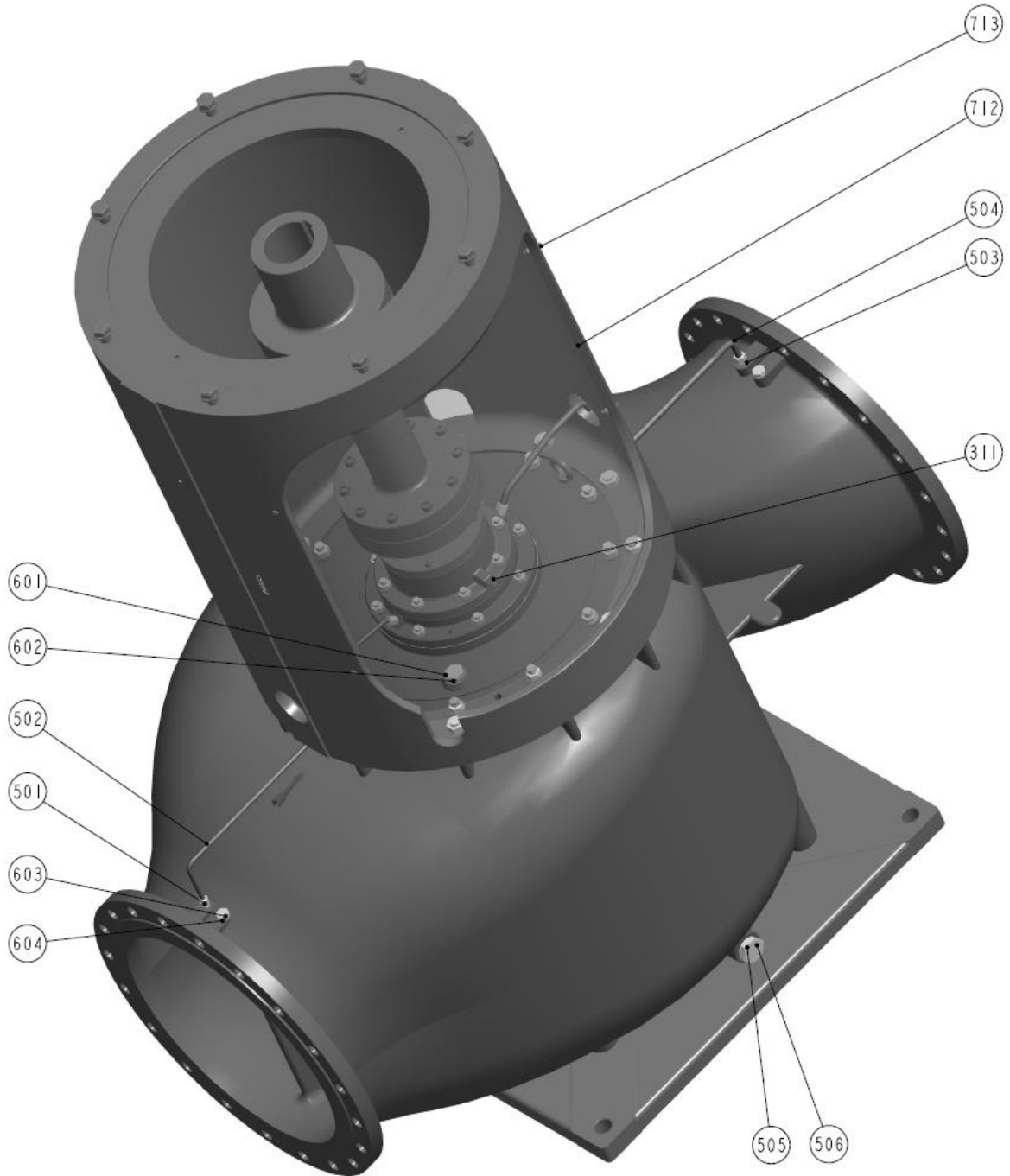

Pos.	Designation	Pos.	Designation
101	PUMP CASING	601	PLUG
102	BASE PLATE	602	SEALING WASHER
103	SET SCREW	603	PLUG
104	NORD-LOCK	604	SEALING WASHER
201	SHAFT	701	COUPLING
202	IMPELLER	702	SPACER SHAFT
203	KEY	703	COUPLING
204	KEY	704	COUPLING BUSH
205	SHAFTNUT	705	ALLEN SCREW
206	POINT SCREW	706	SET SCREW
207	PLASTIC BALL	707	WASHER
301	REAR COVER	708	SET SCREW
302	SEALING COVER	709	THRUST PLATE
303	BEARING HOUSING	710	POINTED SCREW
304	BEARING COVER	711	BRACKET
305	WEAR RING	712	GUARD
306	BEARING	713	SET SCREW
307	MECHANICAL SEAL	901	STUD
308	O-RING	902	NUT
309	O-RING	903	WASHER
310	BALL BEARING	904	STUD
311	LUBRICATOR NIPPLE	905	NUT
312	GASKET	906	WASHER
313	GASKET	907	EYEBOLT
314	SUPPORT DISC	908	STUD
315	POSITION RING	909	NUT
316	LOCK PLATE	910	WASHER
317	V-RING	911	ALLEN SCREW
501	HEX.NIPPLE	912	ALLEN SCREW
502	TUBE		
503	HEX.NIPPLE		
504	TUBE		
505	PLUG		
506	SEALING WASHER		

16.9 DSL500-515/-G-U

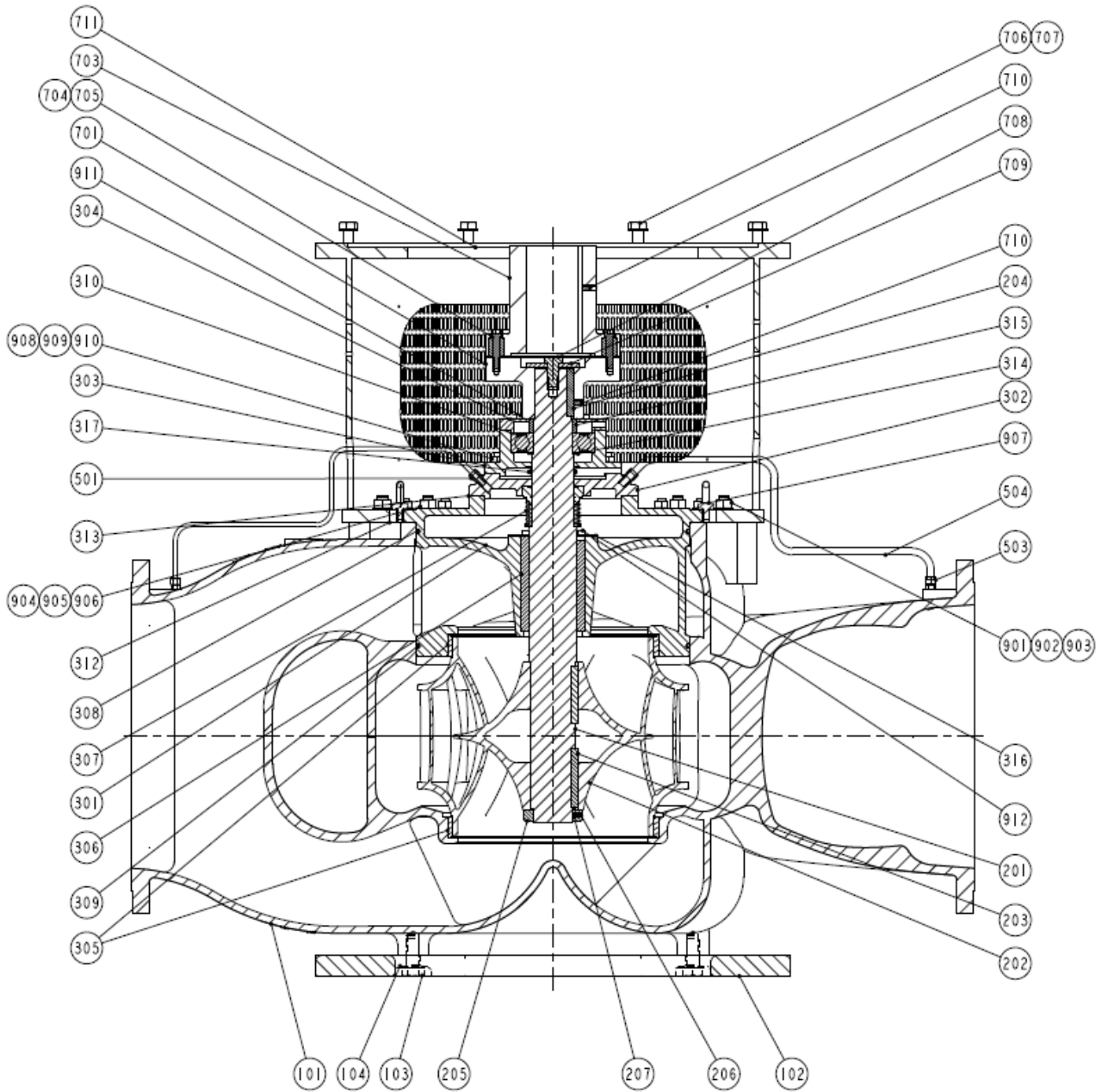

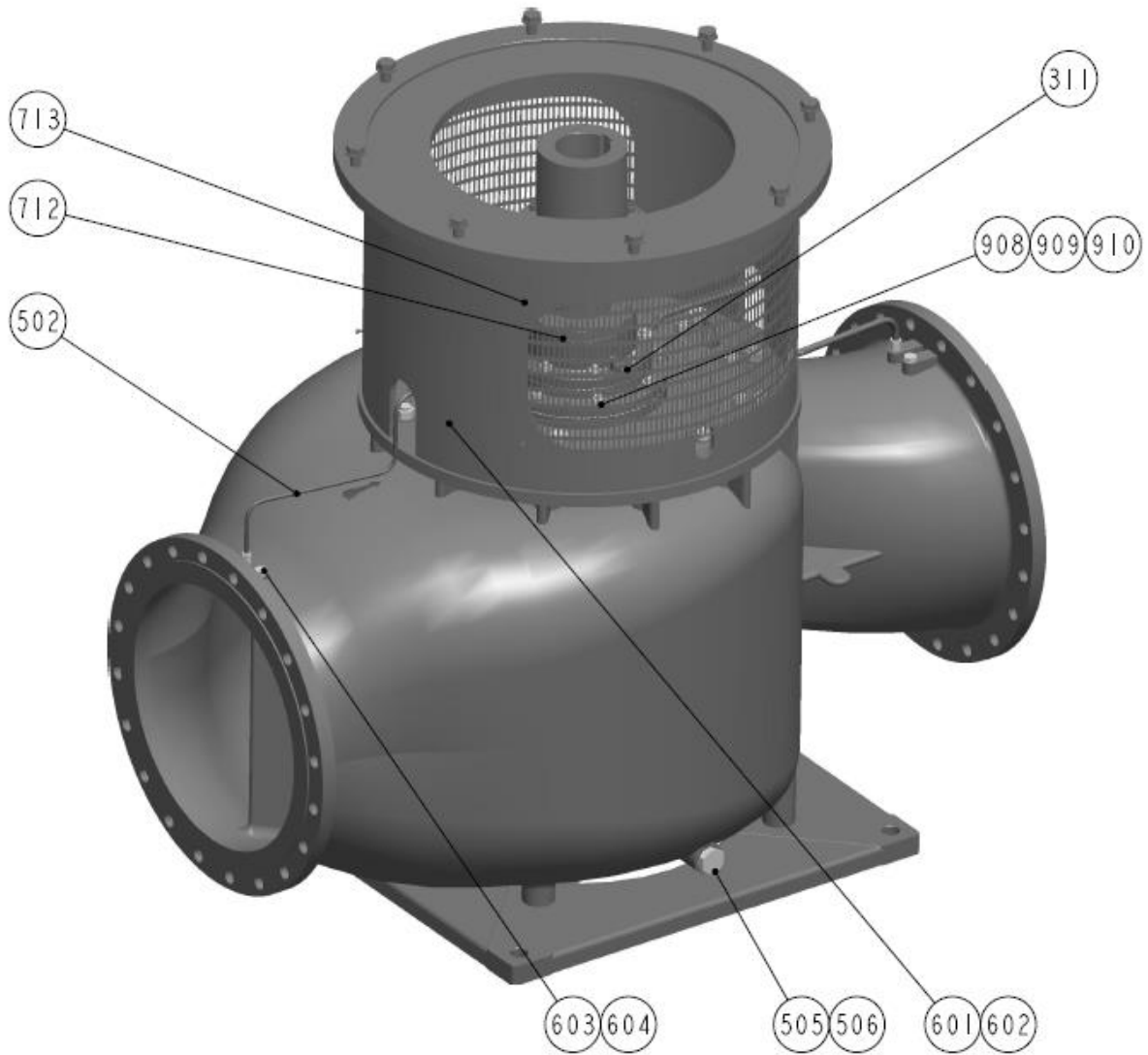

Pos.	Designation	Pos.	Designation
101	PUMP CASING	601	PLUG
102	BASE PLATE	602	SEALING WASHER
103	SET SCREW	603	PLUG
104	NORD-LOCK	604	SEALING WASHER
201	SHAFT	701	COUPLING
202	IMPELLER	702	SPACER SHAFT
203	KEY	703	COUPLING
204	KEY	704	COUPLING BUSH
205	SHAFTNUT	705	ALLEN SCREW
206	POINT SCREW	706	SET SCREW
207	PLASTIC BALL	707	WASHER
301	REAR COVER	708	SET SCREW
302	SEALING COVER	709	THRUST PLATE
303	BEARING HOUSING	710	POINTED SCREW
304	BEARING COVER	711	BRACKET
305	WEAR RING	712	GUARD
306	BEARING	713	SET SCREW
307	MECHANICAL SEAL	901	STUD
308	O-RING	902	NUT
309	O-RING	903	WASHER
310	BALL BEARING	904	STUD
311	LUBRICATOR NIPPLE	905	NUT
312	GASKET	906	WASHER
313	GASKET	907	EYEBOLT
314	SUPPORT DISC	908	STUD
315	POSITION RING	909	NUT
316	LOCK PLATE	910	WASHER
317	V-RING	911	ALLEN SCREW
501	HEX.NIPPLE	912	ALLEN SCREW
502	TUBE		
503	HEX.NIPPLE		
504	TUBE		
505	PLUG		
506	SEALING WASHER		

17. LAYOUT DRAWING

17.1 LAYOUT DRAWING OF DSL150-265/-G-I

NOTES: FLANGES ACC. TO EN1092 PN16

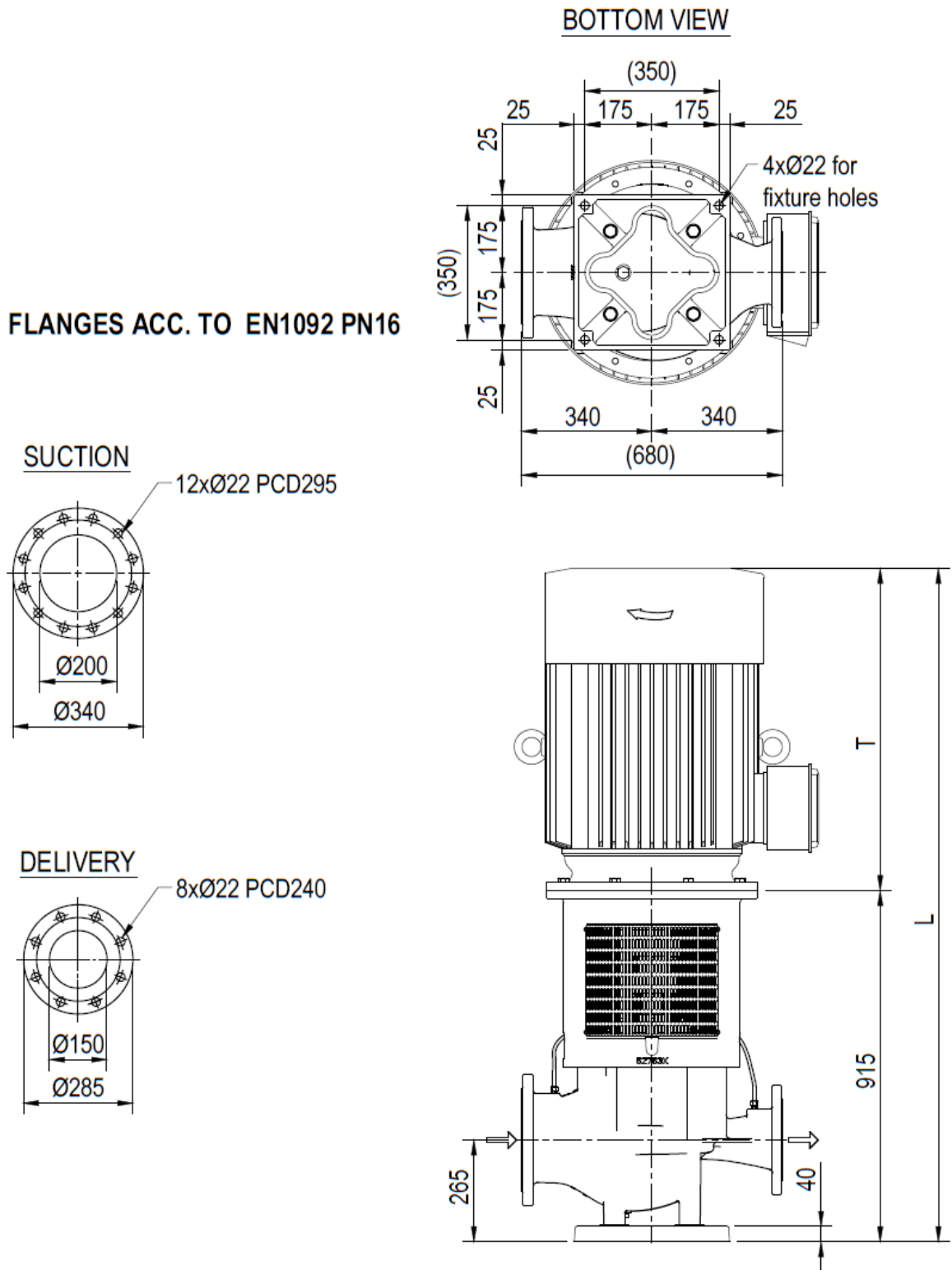

DSL150-265 with heavy bracket

BOTTOM VIEW

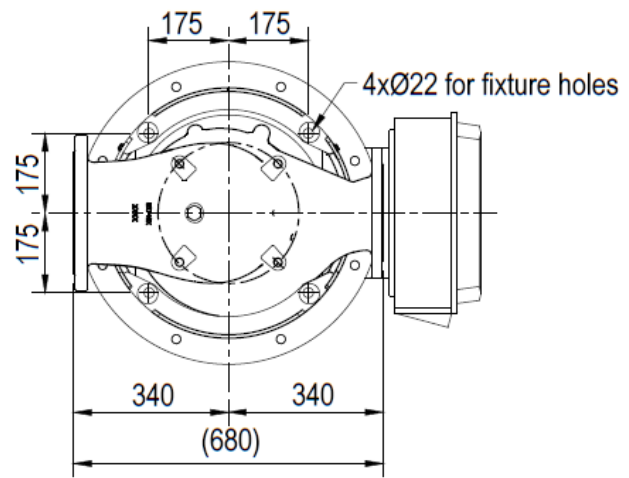

NOTES: FLANGES ACC. TO EN1092 PN16

SUCTION

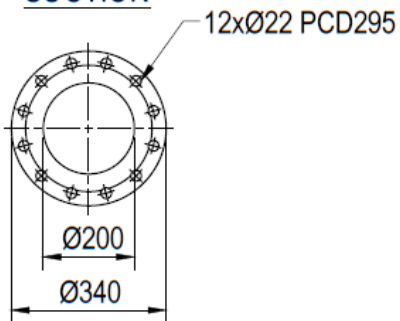

DELIVERY

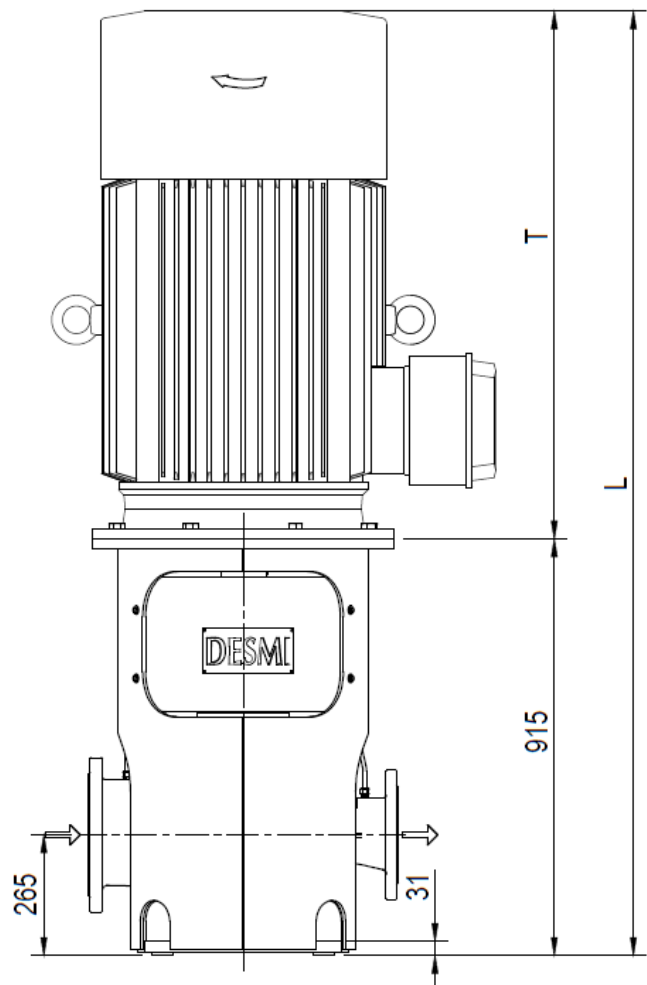
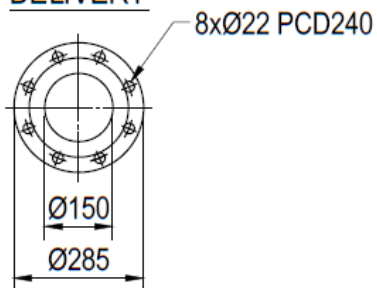

17.2 LAYOUT DRAWING OF DSL250-310-G

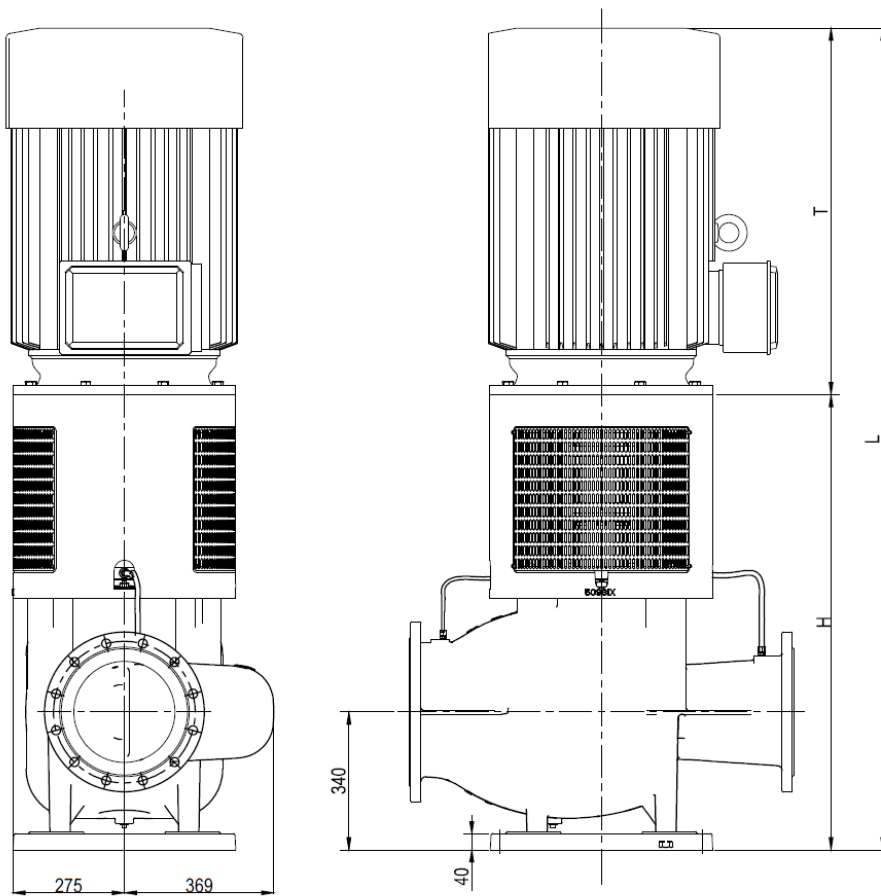
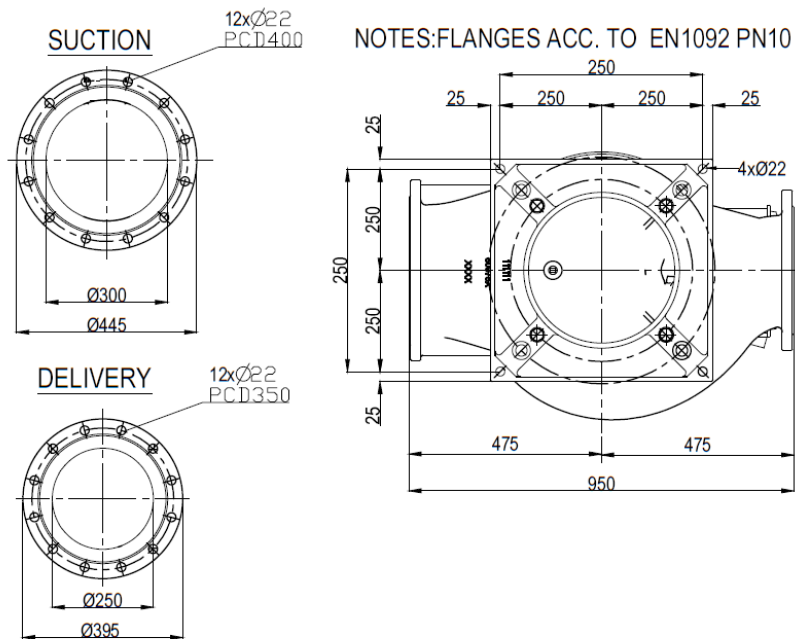

17.3 LAYOUT DRAWING OF DSL250-360/-G

NOTES: FLANGES ACC. TO EN1092 PN10

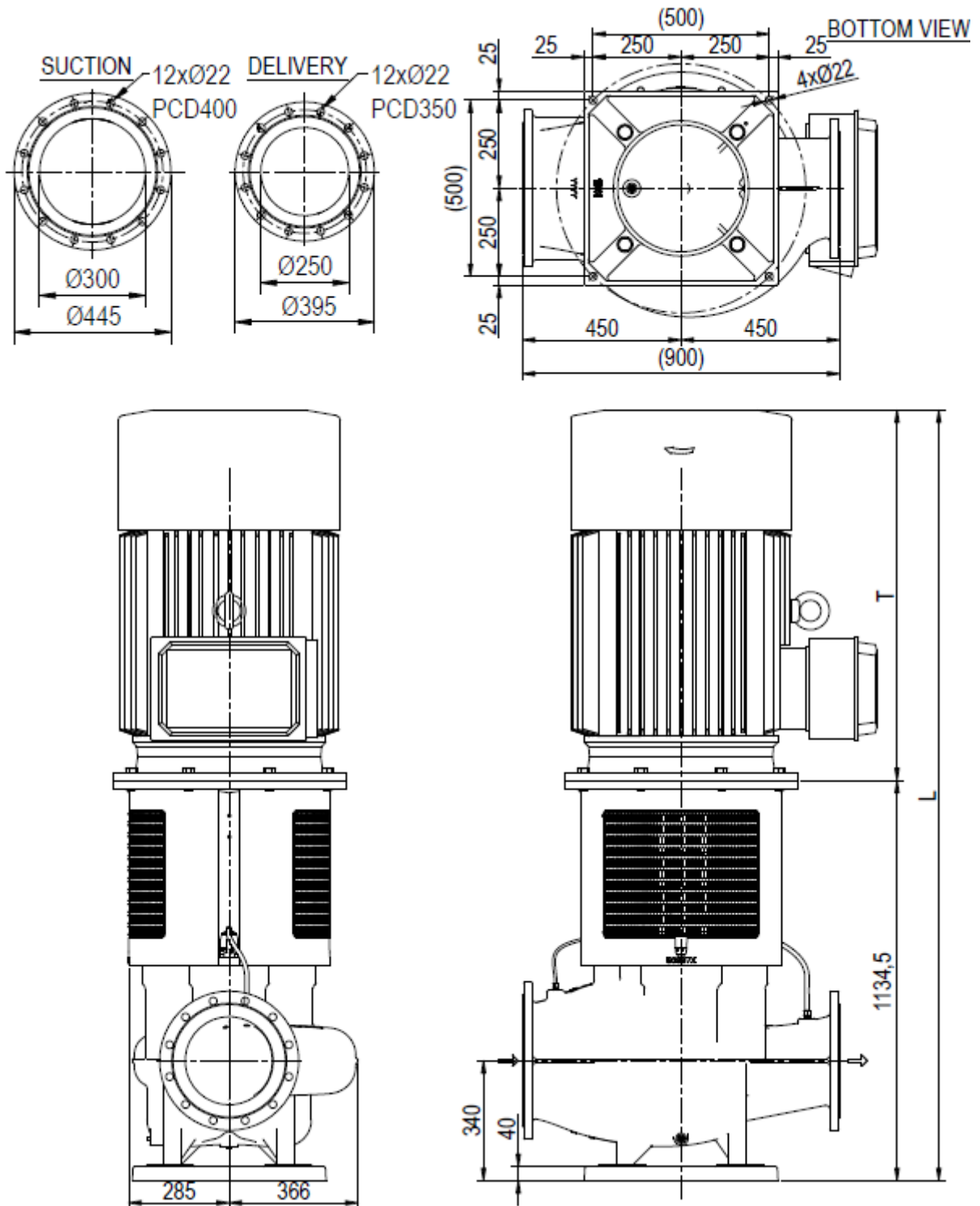

17.4 LAYOUT DRAWING OF DSL300-320/-G

NOTES: FLANGES ACC. TO EN1092 PN10

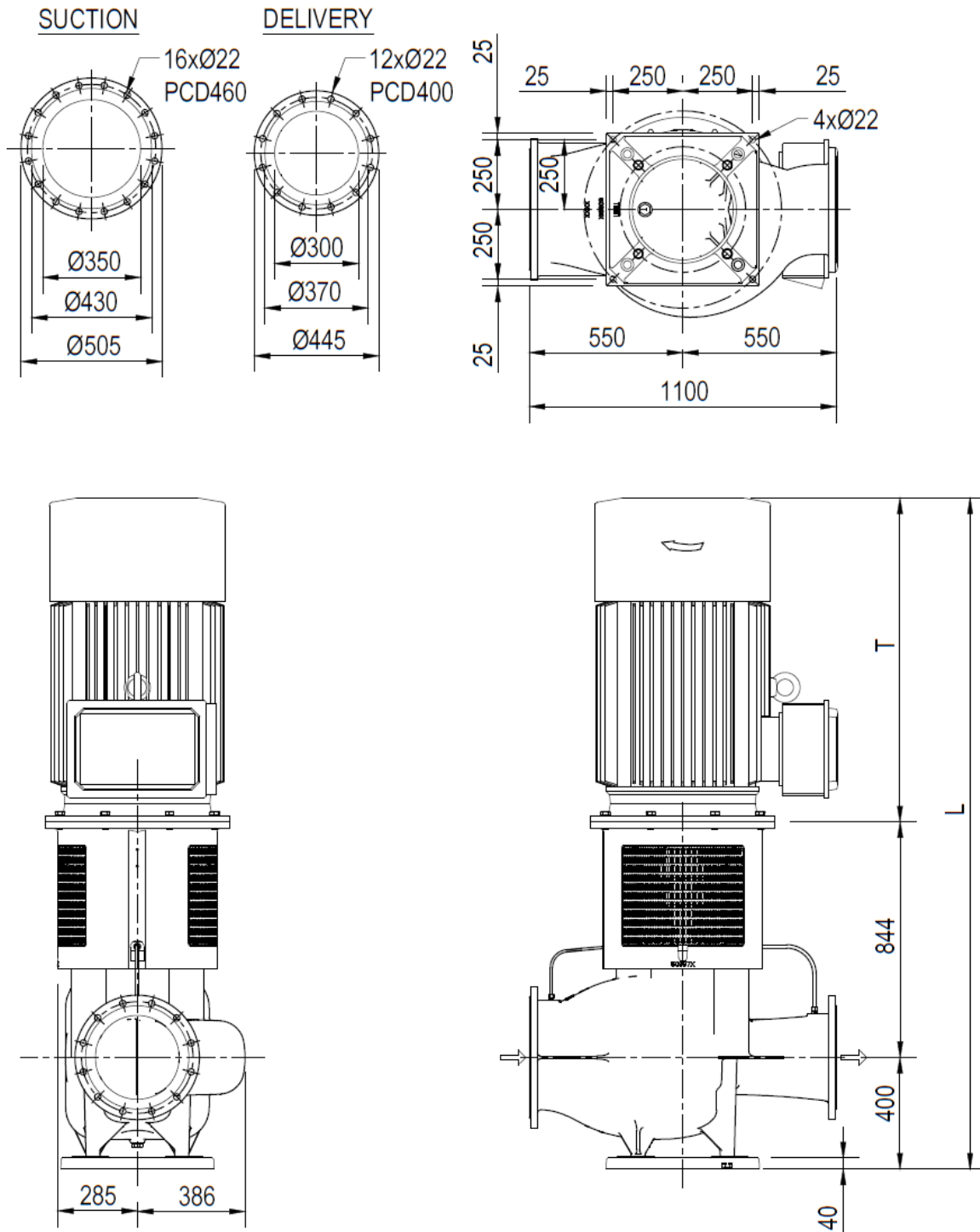

17.5 LAYOUT DRAWING OF DSL300-430/-G

NOTES: FLANGES ACC. TO EN1092 PN16

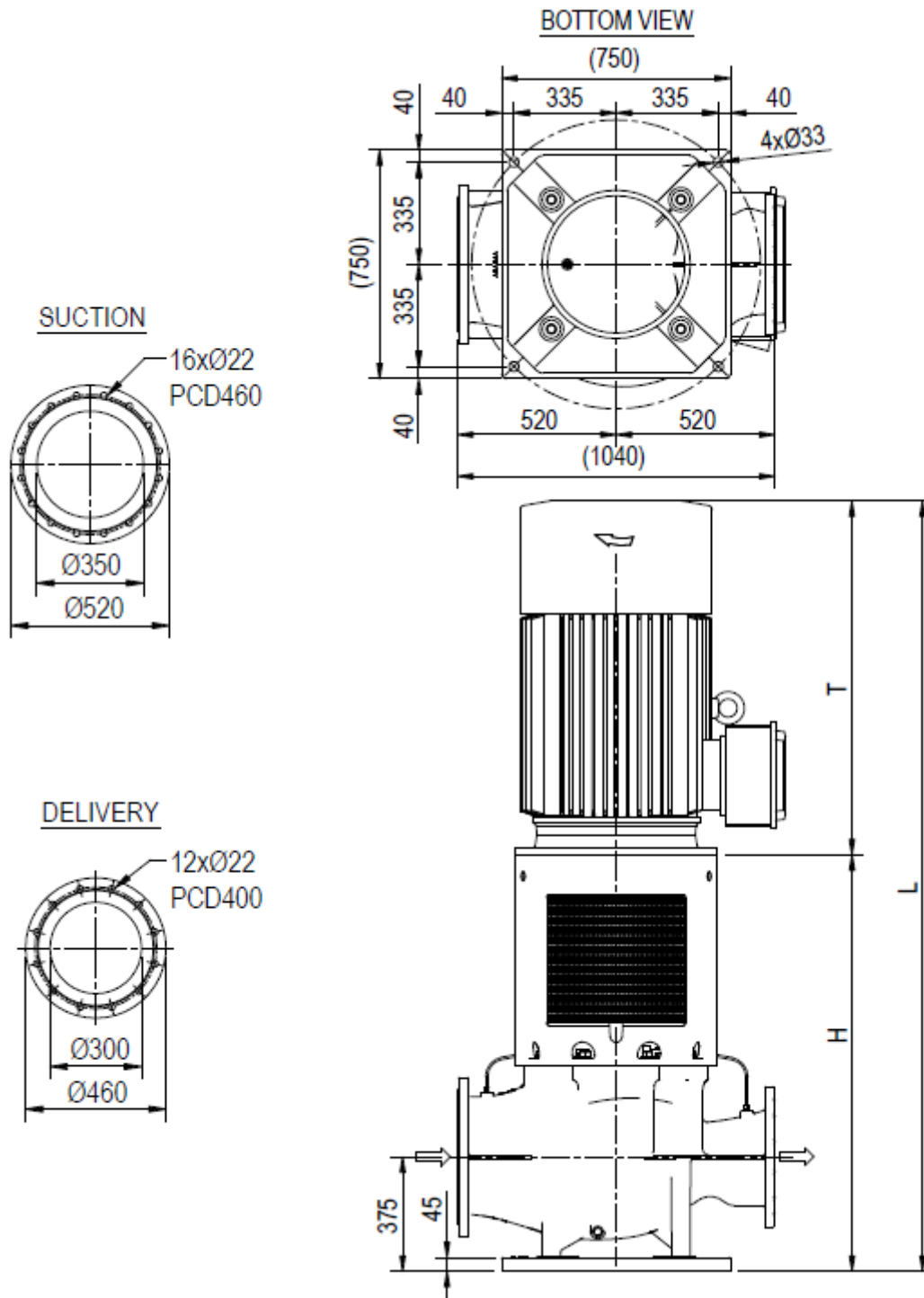

17.6 LAYOUT DRAWING OF DSL300-495/-G

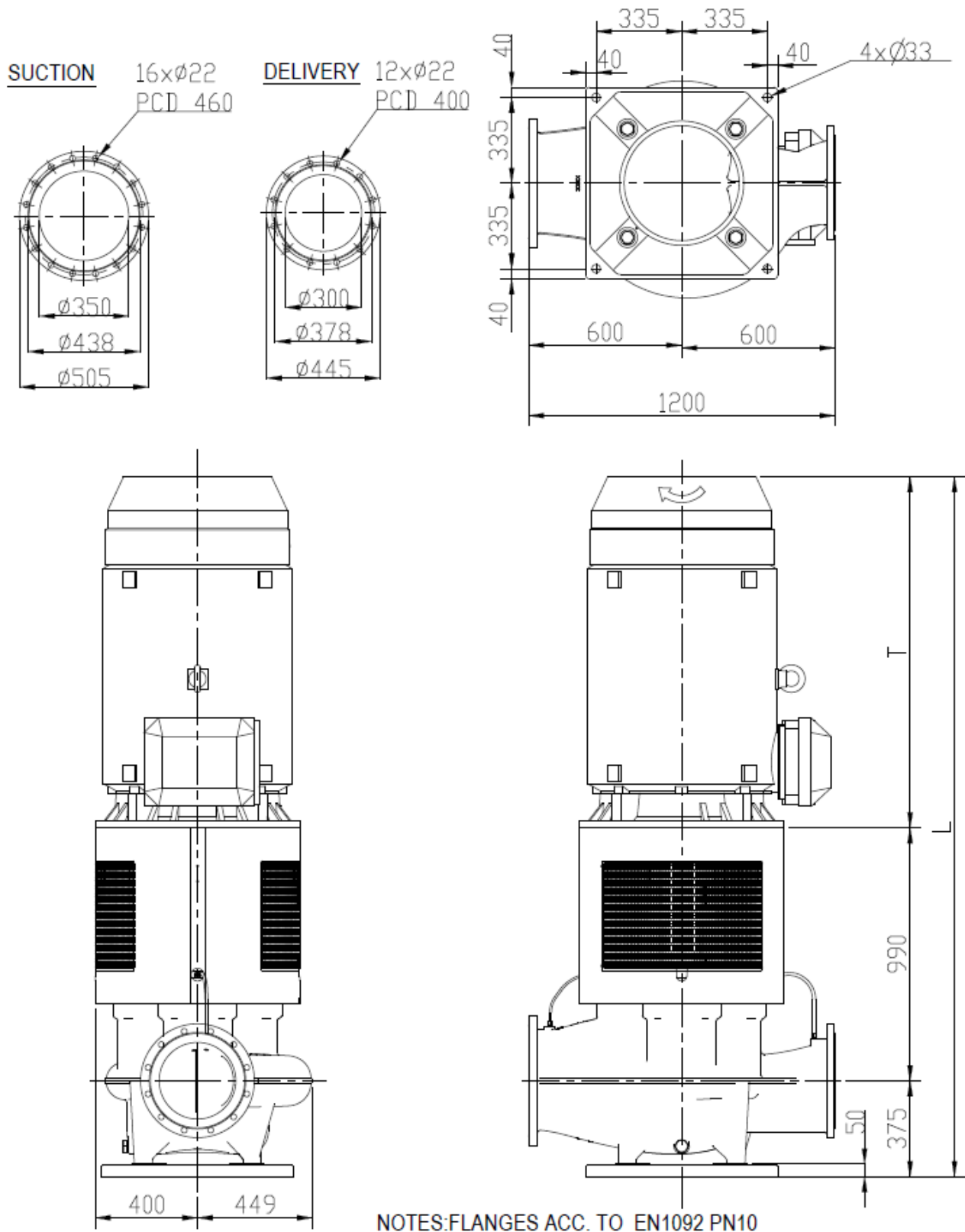

17.7 LAYOUT DRAWING OF DSL350-460/-G

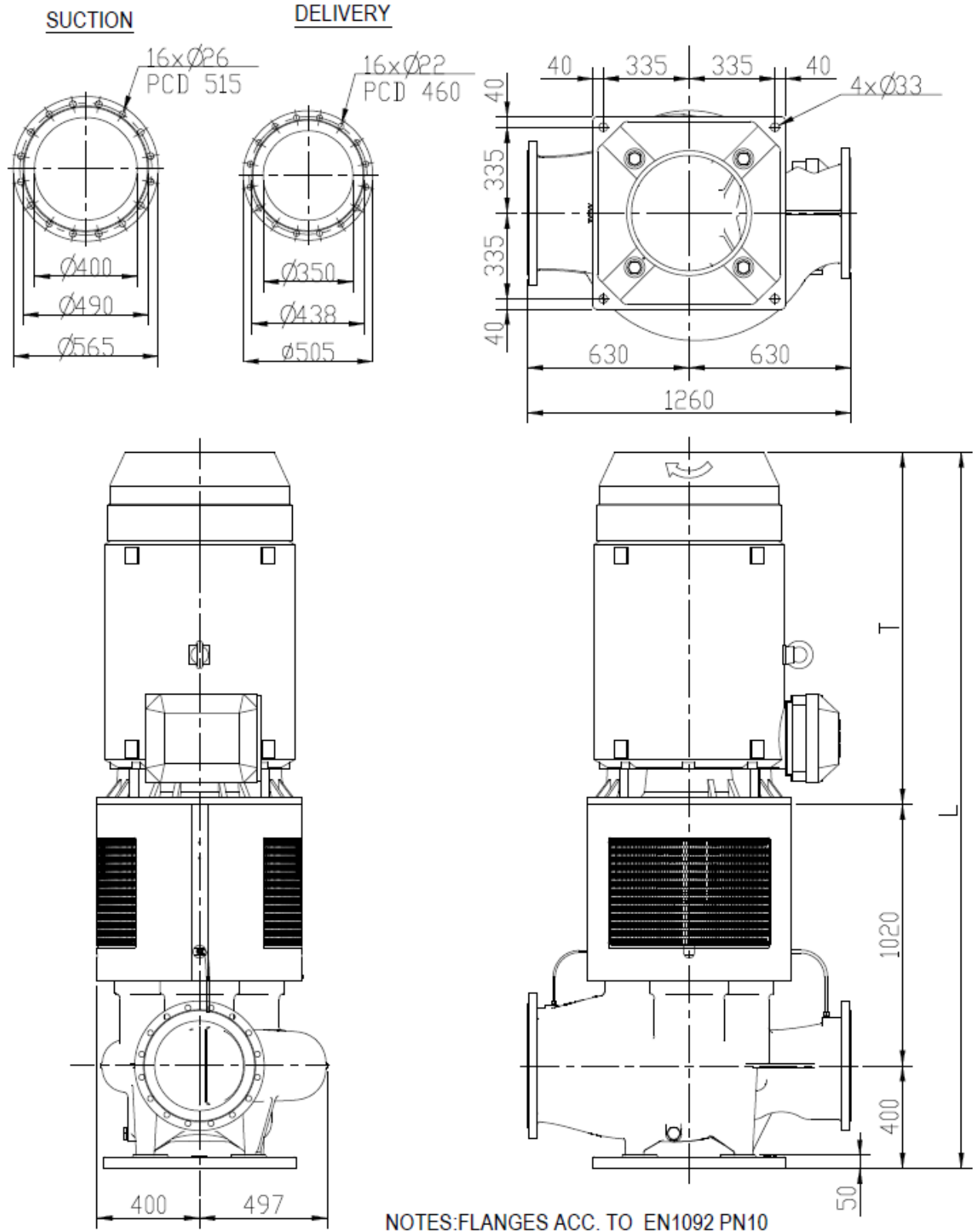

17.8 LAYOUT DRAWING OF DSL400-460/-G

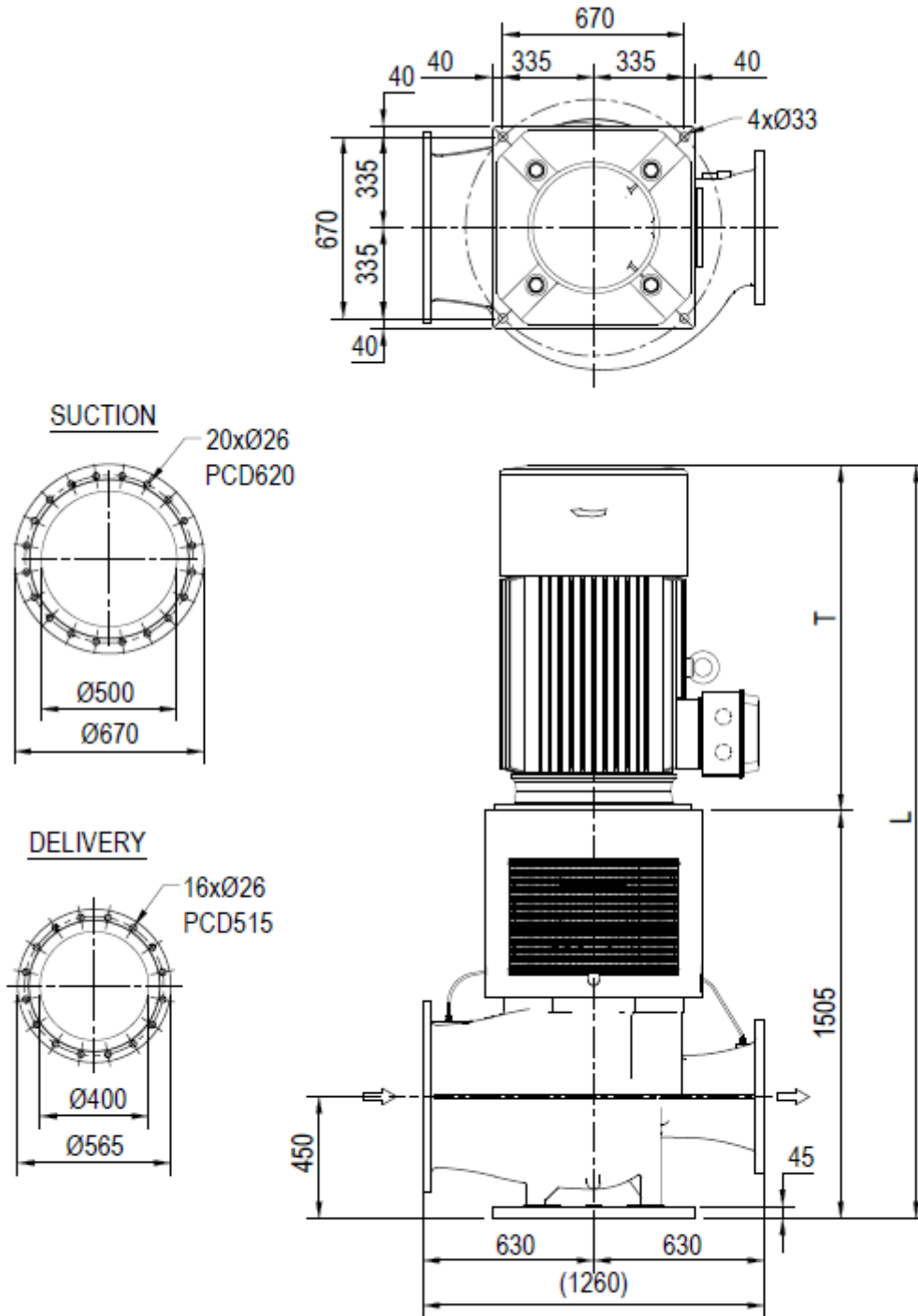

NOTES: FLANGES ACC. TO EN1092 PN10

17.9 LAYOUT DRAWING OF DSL400-498-G-I

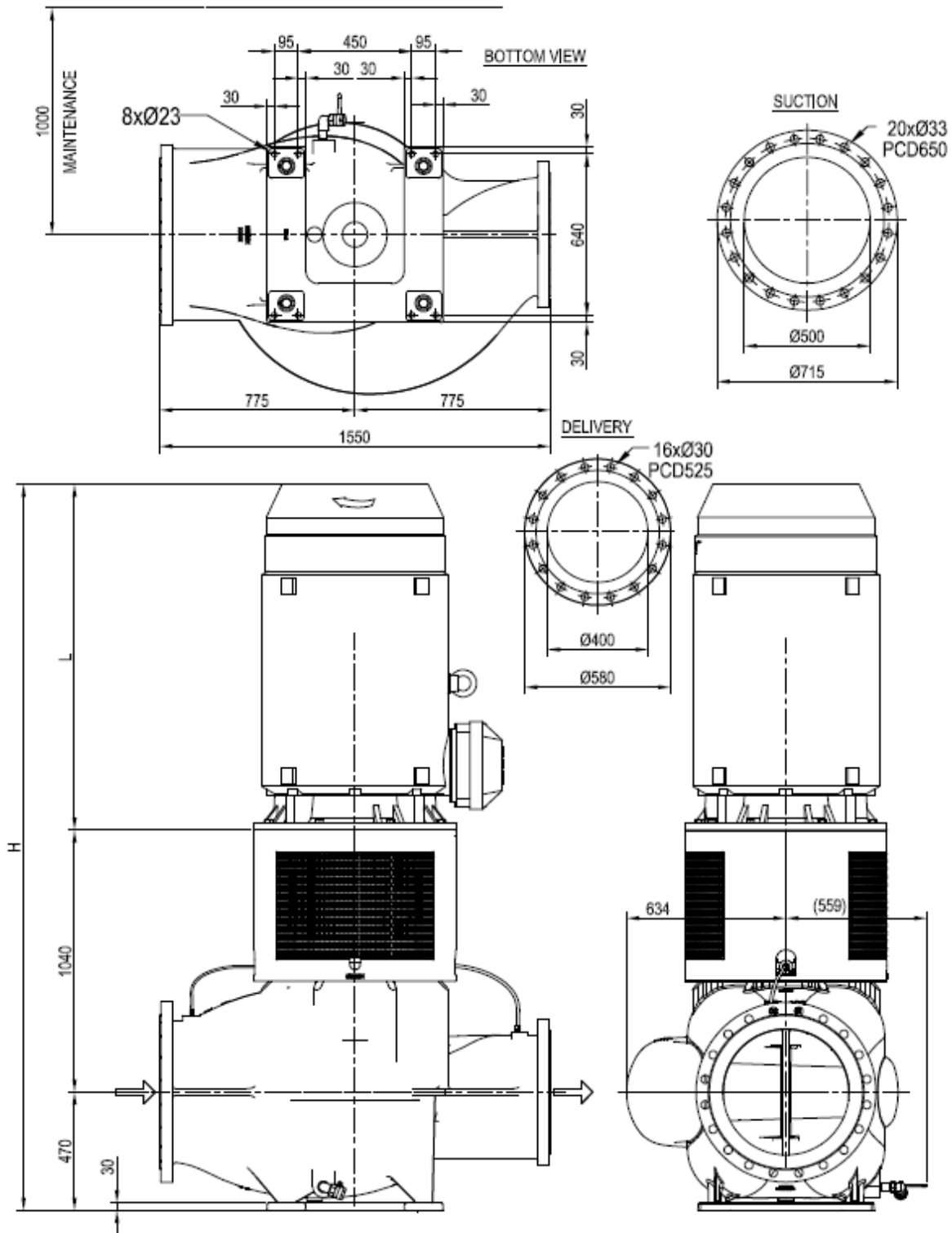

NOTES: FLANGES ACC. TO EN1092 PN16

17.10 LAYOUT DRAWING OF DSL450-490/-G

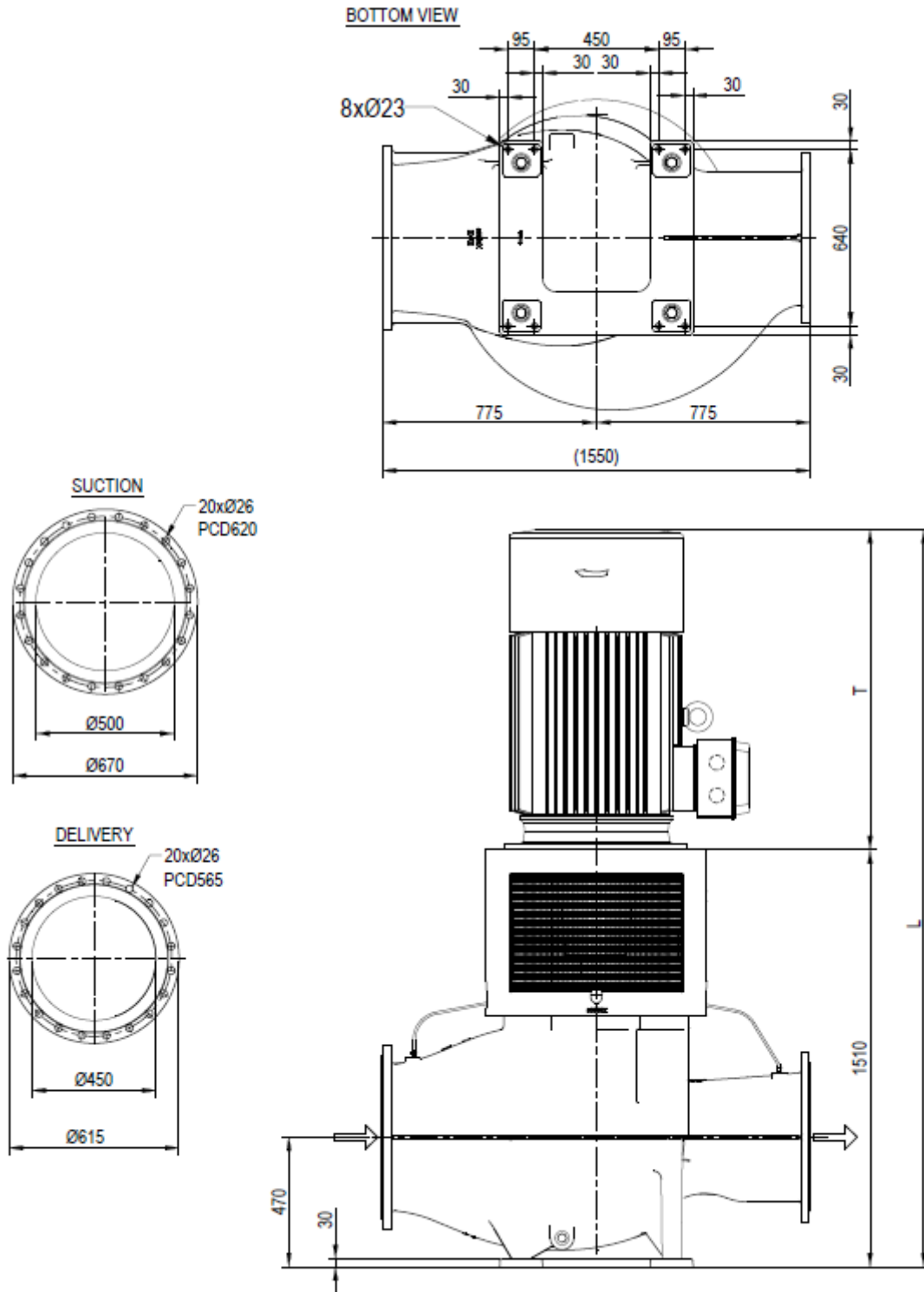

NOTES: FLANGES ACC. TO EN1092 PN10

17.11 LAYOUT DRAWING OF DSL500-490/-G

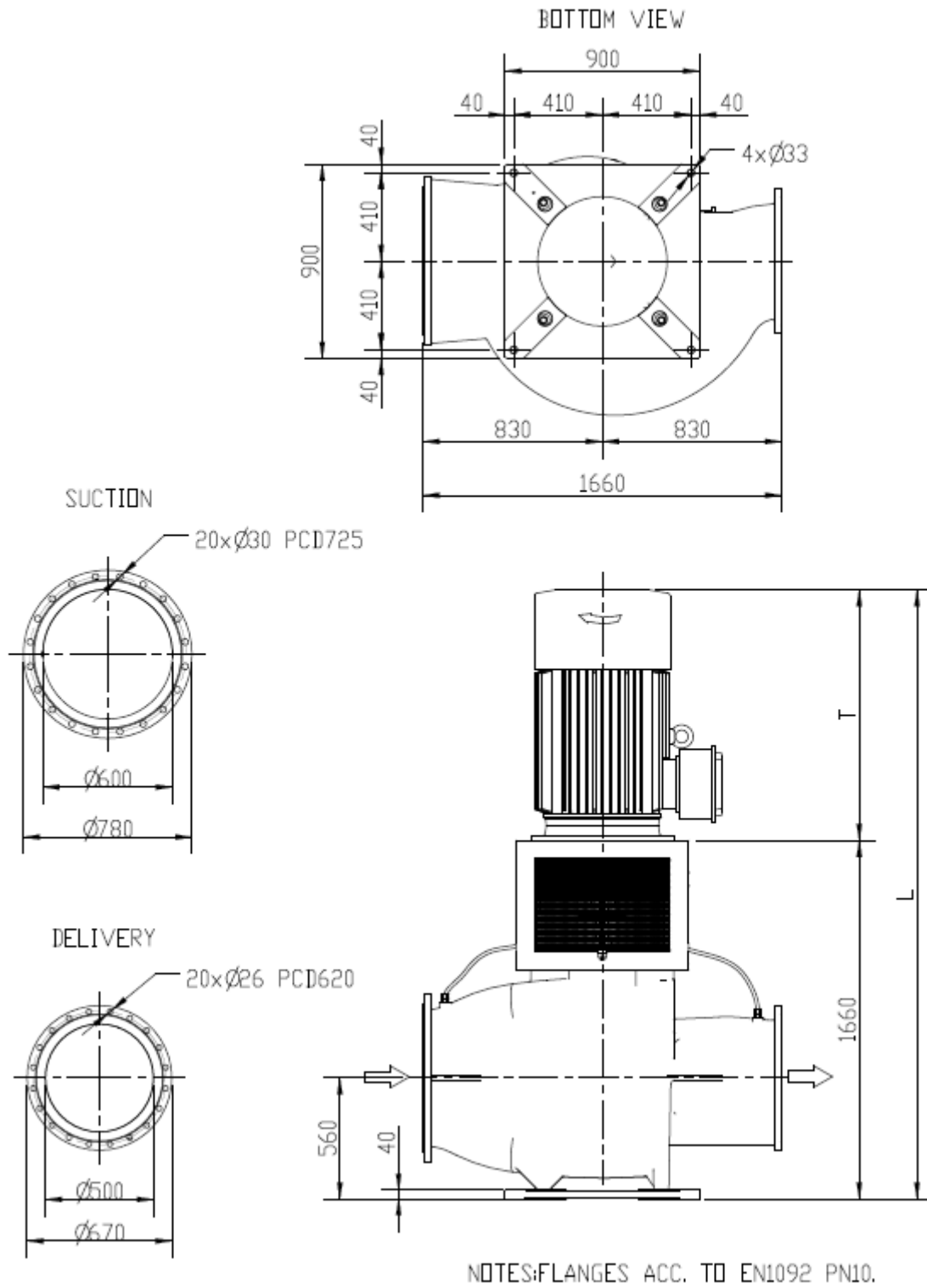

17.12 LAYOUT DRAWING OF DSL500-515/-B-U

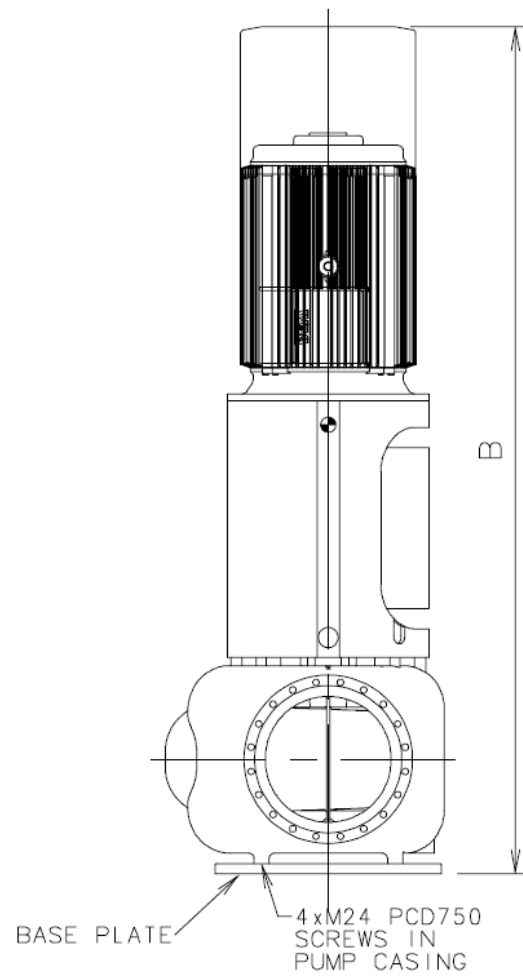
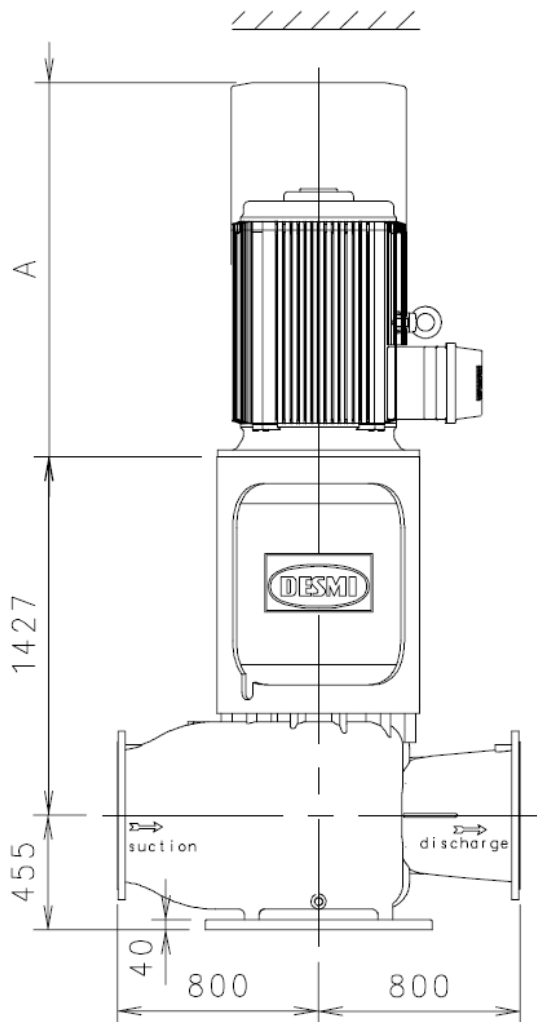
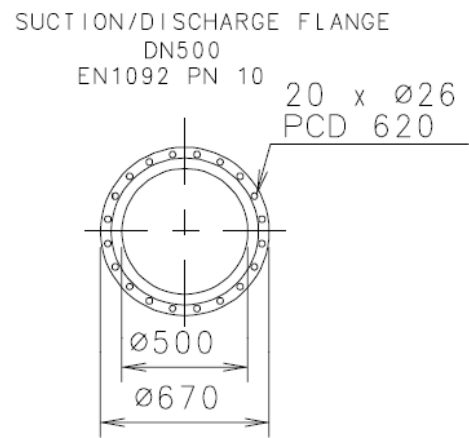
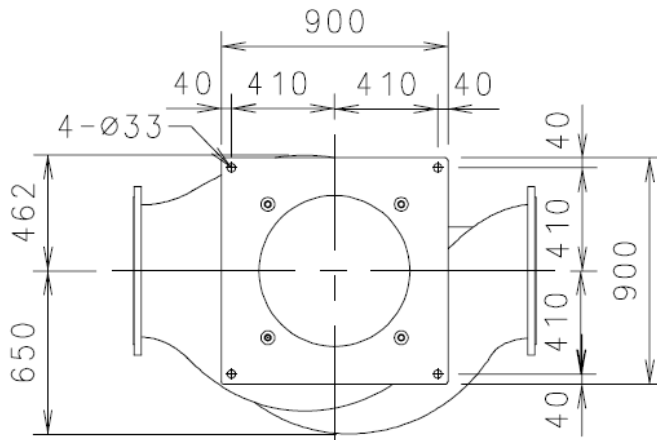

17.13 LAYOUT DRAWING OF DSL500-515/-G-U

BOTTOM VIEW

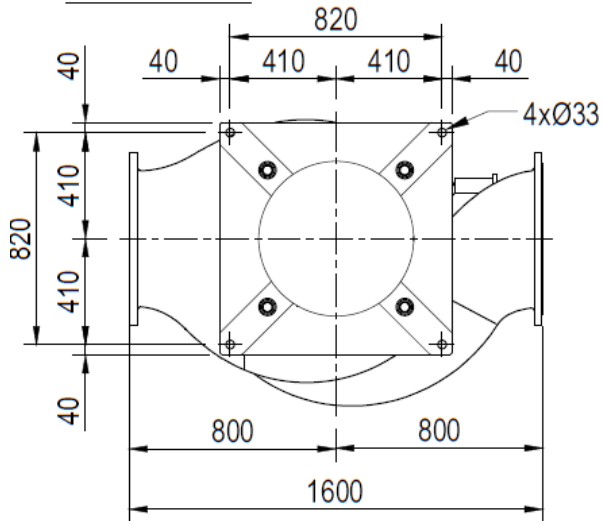

NOTES: FLANGES ACC. TO EN1092 PN10

SUCTION&DELIVERY

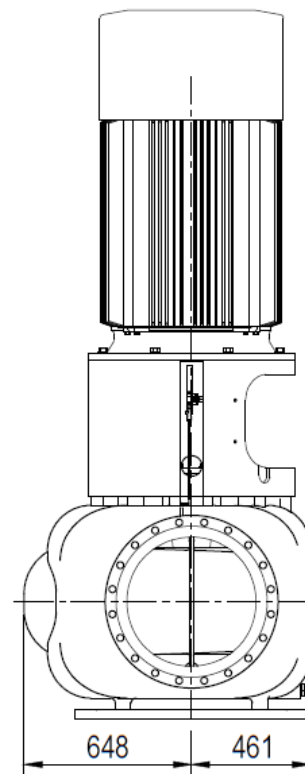
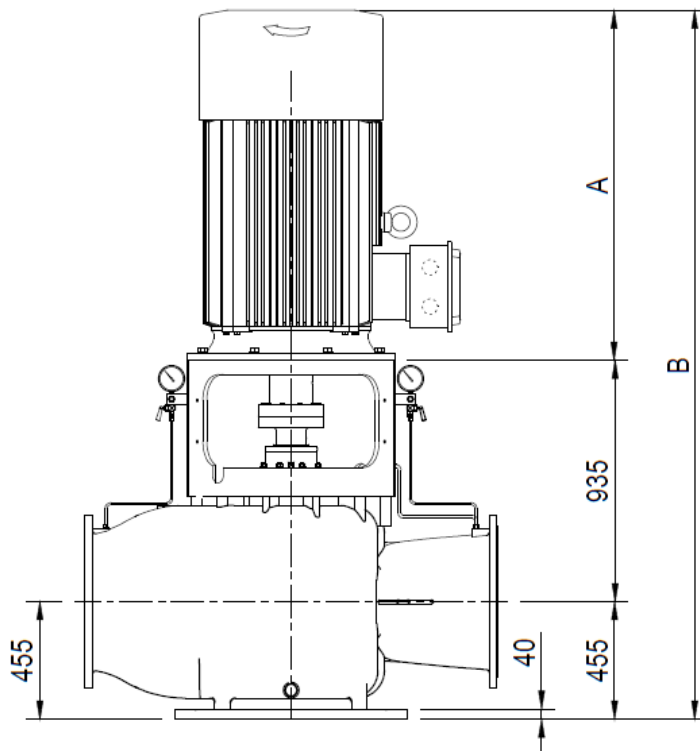
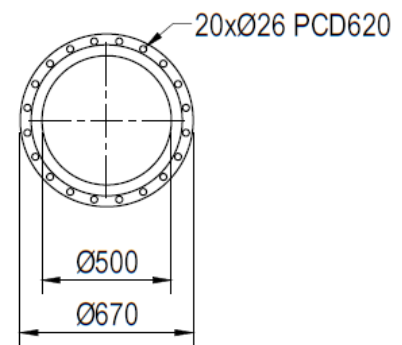

Appendix A

ELK shaft seal fitting in DSL pumps without top ball bearing:

Check length from motor shaft end to motor flange being within +/-0.5 mm of the nominal length (like 80, 110, 140, 170 or 210 mm).

If the motor's shaft end is too short then mount a washer (shim) as shown in the drawing below - for adjusting the pump shaft down to the correct height position which will ensure the correct installation length for the ELK shaft seal.

If the motor's shaft end is too long, it must be shortened to the nominal length.

It must be checked whether the shaft seal is installed with the correct length.

In general regarding ELK shaft seal fitting:

First put a very thin layer of silicone grease on the pump shaft, mount the Stop Ring (Pos. 104) and then mount the rotating part of the ELK shaft seal against the Stop Ring and tighten the three radial pointed screws.

When the pump and motor are completely assembled via the Spacer coupling – i.e. when the pump shaft is raised to its final height position - there must be 44.5 +/-0.5 mm from the sliding surface of the seat out to the end of the rotating part of the ELK shaft seal.

NOTE:

- (1) Never use mineral oil / fat as grease on the pump shaft, as rubber parts as standard are in EPDM.
- (2) Never put grease on the sliding surfaces! They must be completely dry, dust-free and clean during the mounting procedure. Also any fingerprints shall be removed with alcohol or another suitable solvent
- (3) The ELK seal must be rotated after assembly ... so that O-rings, springs and sliding surfaces achieve correct positioning before pressure testing. This is done by mounting the shaft seal as described and later slowly turning the shaft approximately 10 turns by hand - with water in the pump - but without pressure. After this the pump can be started up according to the usual procedure.

Shim insert for correct pump shaft height (might be required for pumps without top ball bearing):

