

OPERATION AND MAINTENANCE INSTRUCTIONS

DESMI vertical "in-line" centrifugal pump

ESL Monobloc

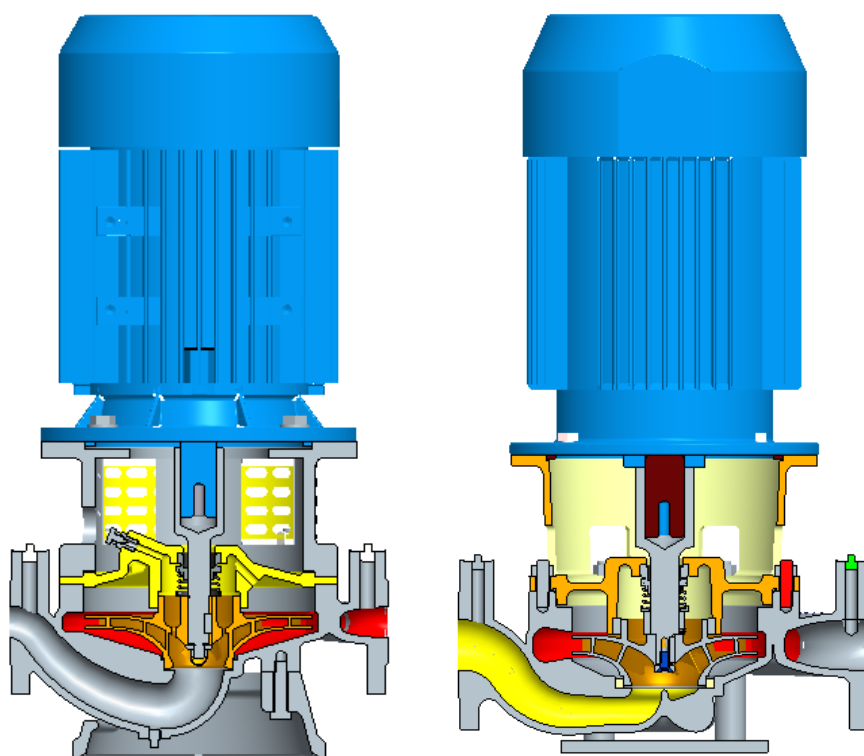

DESMI Pumping Technology A/S

| | | |
|------------------|----------------------|-----------------------|
| Manual: T1515 | Language: English | Revision: N(02/22) |
|------------------|----------------------|-----------------------|

Special pump No.

| | |
|--|-----------|
| OPERATION AND MAINTENANCE INSTRUCTIONS | 1 |
| 1. PRODUCT DESCRIPTION | 3 |
| 1.1 DELIVERY | 3 |
| 2. TECHNICAL DATA | 3 |
| 2.1 EXPLANATION OF THE TYPE NUMBER..... | 3 |
| 2.2 TECHNICAL DESCRIPTION..... | 4 |
| 3. INSTALLATION | 5 |
| 3.1 MOUNTING/FASTENING | 5 |
| 3.2 WIRING | 7 |
| 4. TRANSPORT/STORAGE | 7 |
| 5. DISMANTLING | 8 |
| 5.1 DISMANTLING OF ESL25/40/50/80/100-180 | 8 |
| 5.2 DISMANTLING OF ESL25/32/40/50/65/80/100-180N, ESL80-180N1, ESL65-180M | 10 |
| 5.3 INSPECTION..... | 11 |
| 6. ASSEMBLING | 12 |
| 6.1 FITTING SEALING RINGS (Not applicable for ESL25/32/40/50-180(N)) | 12 |
| 6.2 FITTING SHAFT..... | 12 |
| 6.3 FITTING SHAFT SEAL..... | 12 |
| 6.4 FITTING IMPELLER | 12 |
| 6.5 FITTING CASING COVER OR MOTOR BRACKET | 12 |
| 6.6 FITTING MOTOR FOR ESL25/32/40/50/65/80/100-180N, ESL80-180N1 AND ESL65-180M.... | 12 |
| 6.7 SHAFT | 13 |
| 7. FROST PROTECTION | 14 |
| 8. START-UP | 14 |
| 8.1 START-UP | 14 |
| 9. SYSTEM BALANCING | 15 |
| 10. INSPECTION AND MAINTENANCE | 16 |
| 10.1 DRAINING THE PUMP | 16 |
| 11. REPAIRS | 16 |
| 11.1 ORDERING SPARE PARTS | 16 |
| 11.2 REPLACING THE IMPELLER..... | 16 |
| 11.3 REPLACING WEAR RINGS..... | 16 |
| 11.4 REPLACING SHAFT SEAL (22) | 17 |
| 11.5 REPLACING BALL BEARINGS IN MOTOR..... | 17 |
| 12. OPERATING DATA | 19 |
| 13. EU & UK DECLARATION OF CONFORMITY | 20 |
| 14. INFORMATION RELEVANT FOR DISASSEMBLY OR DISPOSAL AT END-OF-LIFE | 21 |
| 15. ASSEMBLY DRAWING ESL25-180/-12-COMB | 22 |
| 16. ASSEMBLY DRAWING ESL40-180/-12-COMB | 23 |
| 17. ASSEMBLY DRAWING ESL50-180/-12-COMB | 24 |
| 18. ASSEMBLY DRAWING ESL65-180/-12-COMB | 25 |
| 19. ASSEMBLY DRAWING ESL80-180/-12 & ESL80-180B/-12 & ESL80-180E/-12 -COMB. | 26 |
| 20. ASSEMBLY DRAWING ESL100-180/-12-COMB | 27 |

| | |
|--|-----------|
| 21. ASSEMBLY DRAWING ESL25/32/40/50-180N/-12-COMB | 28 |
| 22. ASSEMBLY DRAWING ESL65/80/100-180N/-12 & ESL80-180N1& ESL65-180M/-12-COMB | 29 |
| 23. DIMENSIONAL SKETCH ESL | 30 |

1. PRODUCT DESCRIPTION

These operation and maintenance instructions apply to the DESMI ESL Monobloc pump.

The pump is a single-stage vertical "in-line" centrifugal pump (i.e. horizontal inlet and outlet on the same line) equipped with stainless steel shaft, mechanical shaft seal, and closed impeller.

The impeller is mounted on the motor shaft at a shaft extension. The pumps are equipped with a mechanical seal shaft and have holes in the bracket for inspection of leaks.

1.1 DELIVERY

- Check on delivery that the shipment is complete and undamaged.
- Defects and damages, if any, to be reported to the carrier and the supplier immediately in order that a claim can be advanced.

2. TECHNICAL DATA

The pumps are manufactured in various material combinations which appear from the type number on the name plate. See below.

2.1 EXPLANATION OF THE TYPE NUMBER

All the ESL pumps are provided with a name plate. The type number indicated on the name plate is built up as follows:

ESLXXX-YYY-MR-Z

XXX: Pressure branch diameter, YYY: Standard impeller diameter

M: The material combination of the pump.

R: The assembly combination of the pump.

Z: Other variants

M may be the following:

A: Casing and cover : Cast iron + cast iron alloy. Impeller and sealing rings: Bronze

B: Casing and cover : Cast iron + cast iron alloy. Impeller and sealing rings: Stainless

C: All cast iron

D: Casing and shaft seal cover: Bronze. Impeller and sealing rings: Bronze

S: Casing, shaft seal cover, impeller and sealing rings: SAF2507 and stainless steel alloy

E: Special materials

U: Nonmagnetic material

The pumps can be delivered in other material combinations according to agreement with the supplier.

R may be the following:

02: Monobloc, with bearing in the pump

12: Monobloc, without bearing in the pump

13: Spacer, light bearing housing

14: Spacer, heavy bearing housing

15: Spacer, heavy bearing housing and heavy motor bracket (special motor bracket)

Z may be the following:

- i : PN16 flanges
- j : PN25 flanges
- k : Special flange
- l : Other stuffing box
- m : BS flanges
- n : ANSI flanges
- o : Shockproof design
- p : Other design
- q : JIS flanges

Any use of the pump is to be evaluated on the basis of the materials used in the pump. In case of doubt, contact the supplier.

Pumps in material combinations A and C are primarily used for fresh water.
Pumps in material combination D are primarily used for seawater.

If the pumps are designed for special purposes the following is to be indicated:

Pump No. :
Pump type :
Application :
Comment :

2.2 TECHNICAL DESCRIPTION

The noise level indicated is the airborne noise including the motor. The noise depends on the motor type supplied, as the noise from the pump can be calculated as the noise level of the motor + 2dB(A). The noise level is for pumps with electric motors.

The capacity of the pump appears from the name plate on the pump. If the pump has been delivered without motor, the pump capacity is to be indicated on the plate when mounting the motor.

The permissible loads on the flanges appear from the following table. The values apply to standard pumps in bronze (Rg5) and cast iron (GG20). As to pumps in SG iron (GGG40), NiAlBz or stainless steel the values are to be increased by a factor 1.5.

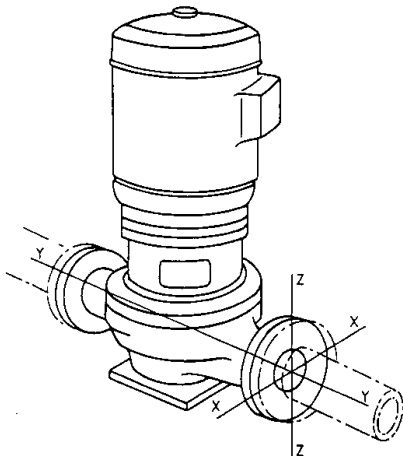

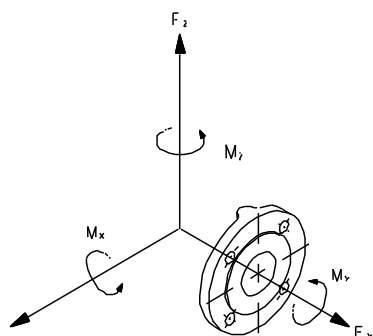

| Piping | DN | Forces (N) | | | | Torques (Nm) | | | |
|--|-----|----------------|----------------|----------------|------|----------------|----------------|----------------|-----|
| | mm | F _y | F _z | F _x | ΣF | M _y | M _z | M _x | ΣM |
| Horizontal pipeline | 25 | 250 | 320 | 250 | 480 | 300 | 150 | 260 | 420 |
| | 32 | 320 | 400 | 320 | 620 | 300 | 150 | 260 | 420 |
| at right angles to the shaft | 40 | 400 | 500 | 400 | 750 | 400 | 200 | 300 | 550 |
| | 50 | 500 | 600 | 550 | 1000 | 450 | 250 | 350 | 600 |
| Suction and pressure flanges above level of installation | 65 | 650 | 840 | 750 | 1340 | 510 | 310 | 380 | 700 |
| | 80 | 800 | 950 | 850 | 1500 | 550 | 350 | 400 | 750 |
| | 100 | 1000 | 1250 | 1150 | 2000 | 650 | 400 | 500 | 900 |

In connection with the permissible loads on the flanges the following is to be observed:

$$\left(\frac{\Sigma F_{calculated}}{\Sigma F_{Max.permissible}} \right)^2 + \left(\frac{\Sigma M_{calculated}}{\Sigma M_{Max.permissible}} \right)^2 < 2$$

where index "calc" is the values calculated by the user.

At the same time none of the forces or moments may exceed the indicated figure multiplied by 1.4.

3. INSTALLATION

3.1 MOUNTING/FASTENING

Insert the pump in the pipeline in the same way as a valve. The pump can be inserted in both horizontal and vertical pipes, but not in a horizontal pipe if the motor is placed below horizontal level. The max. loads on the flanges appear from the technical description.

When installing the pump check that it is earthed to avoid an electrical potential in the pump.

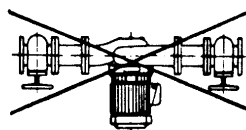
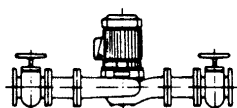
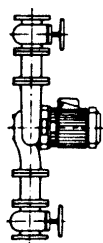

The max. permissible loads on the flanges stated in paragraph 2.2 are to be observed.

At installations pumping hot or very cold liquids, the operator must be aware that it is dangerous to touch the pump surface and, consequently, he must take the necessary safety measures.

3.2 WIRING



Wiring to be carried out by authorised skilled workmen according to the rules and regulations in force.

4. TRANSPORT/STORAGE

The weights of the pumps in A and D combination (without motor) are stated in the following table, and the pumps are to be lifted as shown below.

| Pump | Weight in kg A12 / D12 comb. Incl. base plate |
|-------------|---|
| ESL25-180 | 30/32 |
| ESL25-180N | 30/32 |
| ESL32-180N | 32/35 |
| ESL40-180N | 35/38 |
| ESL40-180 | 37/40 |
| ESL50-180N | 42/44 |
| ESL50-180 | 41/44 |
| ESL65-180M | 63/70 |
| ESL65-180N | 63/70 |
| ESL65-180 | 62/69 |
| ESL80-180N1 | 67/74 |
| ESL80-180N | 67/74 |
| ESL80-180 | 64/71 |
| ESL80-180B | 64/71 |
| ESL80-180E | 65/73 |
| ESL100-180N | 78/87 |
| ESL100-180 | 76/87 |

The pump is to be stored in a dry area.
Before shipment the pump is to be fastened securely on pallets or the like.

The pump is to be lifted in the following way:

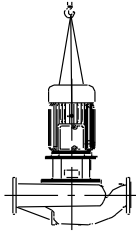

The lifting straps must not bear against sharp edges and corners.

5. DISMANTLING



Before dismantling the pump make sure that it has stopped. Empty the pump of liquid before it is dismantled from the piping system. If the pump has been pumping dangerous liquids you are to be aware of this and take the necessary safety measures.

If the pump has been pumping hot liquids, take great care that it is drained before it is removed from the piping system.

5.1 DISMANTLING OF ESL25/40/50/80/100-180

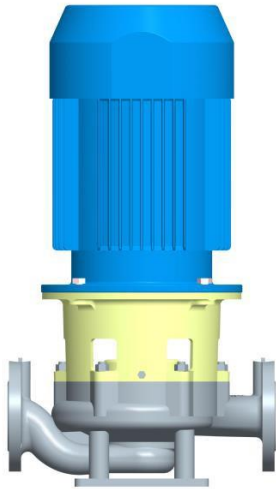

Before dismantling

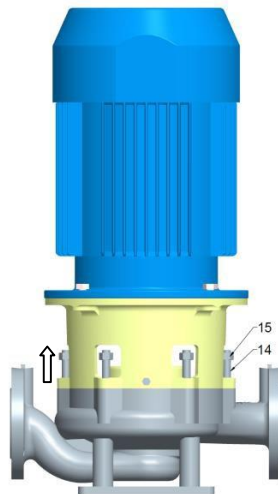

1. Remove nut (15) and stud (14);

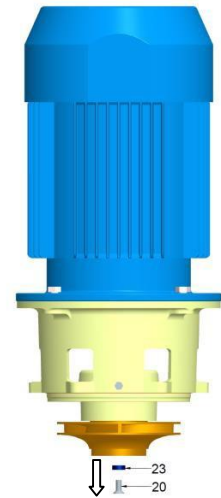

2. Remove screw (20) and washer (23);

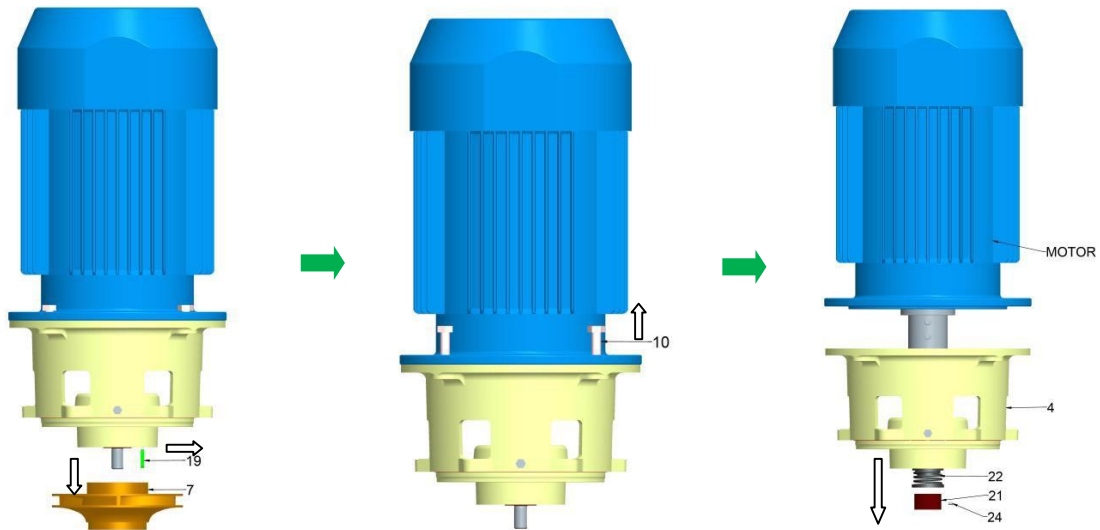

3. Remove the impeller (7)/(2)/(5) and the key (19)

4. Remove set screw (10)

5. Remove pointed screw (24), pull casing cover (4) and stop ring(21) and shaft seal(22) and motor with shaft apart;

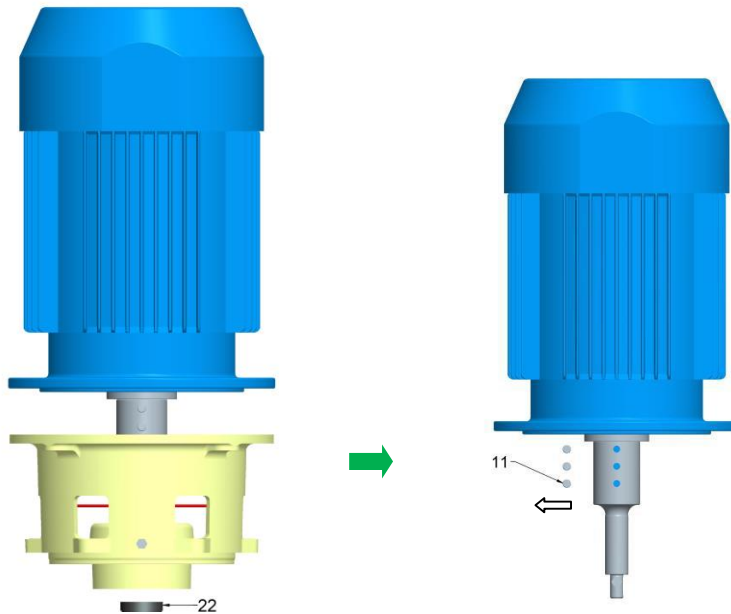

6. Press out the seat (22);

7. If necessary, remove pointed screw (11) to pull off the shaft;

5.2 DISMANTLING OF ESL25/32/40/50/65/80/100-180N, ESL80-180N1, ESL65-180M



Before dismantling

1. Remove the flush pipe (29) for ESL25/32/40/50-180N, remove venting plug (5), muff (9) and sleeve (21) for ESL65/80/100-180N and ESL65-180M

2. Remove nut (15) and stud (14);

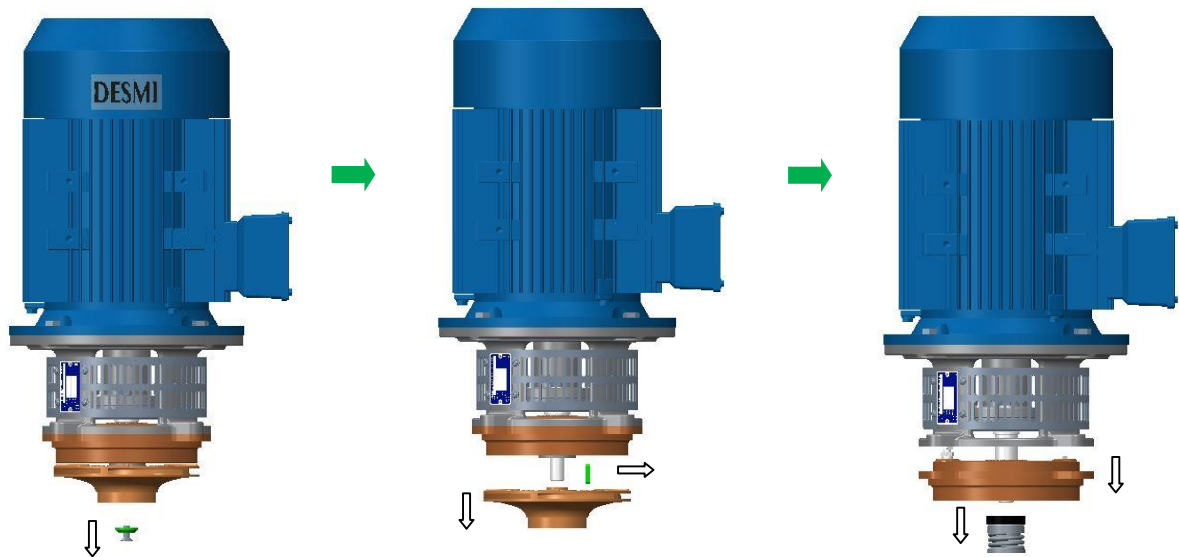

3. Remove screw (20, 24 in ESL25/32/40/50-180N) and washer (23, 25 in ESL40/50-180N);

4. Remove the impeller (2, 5 in ESL25/32/40/50-180N) and the key (19)

5. Remove shaft seal (22, 522 in ESL25/32/40/50-180N) and rear cover (4, 7 in ESL25/32/40/50-

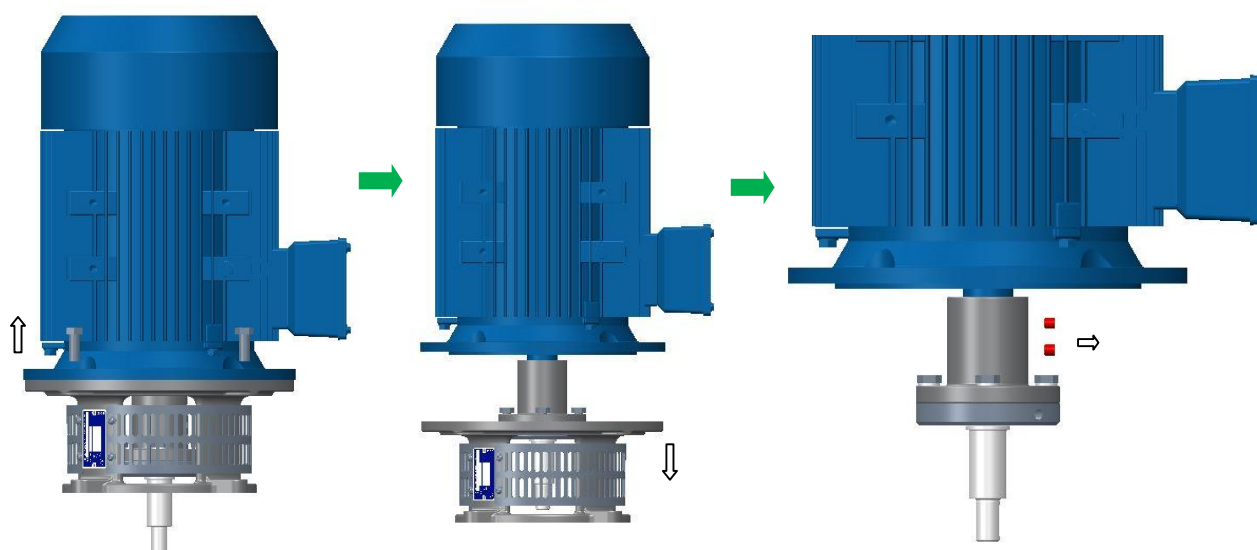

6. Remove set screw
(10, 810 in ESL25/32/40/50-180N)

7. Remove motor bracket
(7, 104 in ESL25/32/40/50-180N)

8. If necessary, remove pointed screw (11, 311 in ESL25/32/40/50-180N) to pull off the coupling

5.3 INSPECTION

When the pump has been dismantled, check the following parts for wear and damage:

- Sealing ring/impeller: Max. clearance 0.3-0.6 mm measured in radius.
- Shaft seal/shaft seal cover: Check the seat for flatness and cracks.
Check the rubber parts for elasticity.

6. ASSEMBLING

Refer to the reverse process of dismantling.

6.1 FITTING SEALING RINGS (Not applicable for ESL25/32/40/50-180(N))

When fitted the wear ring (17) is to bear against the shoulder of the pump casing (1).

When fitted the wear ring (16) is to bear against the shoulder of the casing cover (4).

6.2 FITTING SHAFT

For ESL40/50/65/80/100-180, fit the shaft flange (8) (Not applicable for ESL25-180) and the shaft (6) in the motor, then fit the pointed screw (11).

6.3 FITTING SHAFT SEAL

Before fitting the seat, clean the recess in the shaft seal cover (ESL 25-180) or the motor bracket or rear cover (ESL25/32/40/50/65/80/100-180N, ESL80-180N1, ESL65-180M).

When fitting the seat, remove the protective coating without scratching the lapped surface.

Dip the outer rubber ring of the seat into soapy water. Now press the seat into place with the fingers and check that all parts are correctly imbedded.

If it is necessary to use tools for assembling, then protect the sliding surface of the seat to prevent it from being scratched or cut. Lubricate the inner surface of the slide ring rubber bellows with soapy water and push it over the shaft. The use of a conical fitting bush as shown on the assembly drawing is recommended to avoid that the rubber bellows is cut.

Push the slide ring over the shaft with the hand. If the rubber bellows is tight, use a fitting tool and take care that the slide ring is not damaged. If the carbon ring is not fixed, it is important to check that it is fitted correctly, i.e. the chamfered/lapped side is to face the seat. The carbon ring can be held by a little grease.

When using soapy water on the shaft, the bellows will settle and seat in abt. 15 minutes, and until then tightness should not be expected. After start, check by viewing the leak hole that there are no leaks.

6.4 FITTING IMPELLER

Fit the key in the shaft and lead the impeller towards the shoulder of the shaft. Fit the stop ring (21) before the impeller, (2)/(7)/(5). Take care that the ring at the end of the shaft seal spring locates in the recess of the impeller. Secure the impeller with washers (23) and a nut/screw (20, for ESL25/32/40/50-180N is 24).

6.5 FITTING CASING COVER OR MOTOR BRACKET

Place the O-ring (3, for ESL25/32/40/50-180N is 703) (or gasket in ESL25-180 12) between pump casing and motor bracket (or casing cover in ESL25-180 12 combination or rear cover in ESL25/32/40/50/65/80/100-180N, ESL80-180N1 and ESL65-180M) in the O-ring groove and hold it with a little grease. However, check the material of the O-ring first. As standard the material is nitrile, but it might be EPDM which will be damaged by mineral grease. Use soft soap or silicone grease for EPDM. Fit and fasten shaft seal cover or motor bracket, mounted with the electric motor, in the pump casing. Screw the pointed screws back into the shaft seal cover before tightening. Fit circulation pipe (29) in ESL25/32/40/50-180N.

6.6 FITTING MOTOR FOR ESL25/32/40/50/65/80/100-180N, ESL80-180N1 AND ESL65-180M

Fit the motor coupling (8, 108 in ESL25/32/40/50-180N) to motor shaft and tighten the pointed screw (11, 311 in ESL25/32/40/50-180N) slightly, place motor onto bracket (7, 104 in ESL25/32/40/50-180N) and tighten the set screw (10, 810 in ESL25/32/40/50-180). Add 2 shims (301) between motor coupling (8, 108 in ESL25/32/40/50-180N) and pump shaft flange (6, 206 in ESL25/32/40/50-180N), adjust the motor coupling to make it resist on the shims to ensure it is at the right axial position. Tighten the pointed screw (11, 311 in ESL25/32/40/50-180) and remove the shims (301). Tighten the set screw (25, 17 in ESL25/32/40/50-180N) to

lift up the impeller to a right position.

Regarding the tightening torque of pointed screw (11, 311 in ESL25/32/40/50-180N)

| Motor Size | Dimension Point Screws | Torque Pointed Screws |
|--------------------|------------------------|-----------------------|
| 71/80 | M6 | 10Nm |
| 90/100/112/132/160 | M8 | 24Nm |

6.7 SHAFT

When the pump has been assembled, check that the shaft rotates freely. In case the shaft has been dismantled in the combination, tap the shaft towards the shaft end of the electric motor by means of a plastic hammer, and fasten the pointed screws (first the middle screw) according to the below table. Check that the wobble, measured as close to the shaft end as possible, is within the limits indicated in the table.

| Motor Size | Dimension Point Screws | Torque Pointed Screws | Max.Wobble |
|------------|------------------------|-----------------------|------------|
| 71 | M6 | 10Nm | 70um |
| 80 | M6 | 10Nm | 70um |
| 90 | M8 | 24Nm | 70um |
| 100/112 | M8 | 24Nm | 70um |
| 132 | M10 | 40Nm | 70um |
| 160 | M12 | 75Nm | 70um |

7. FROST PROTECTION

Pumps which are not in operation during frost periods are to be drained to avoid frost damage. Remove the plug at the bottom to empty the pump. Alternatively, it is possible to use anti-freeze liquids in normal constructions.

8. START-UP

A centrifugal pump will not function until it has been filled with liquid between the foot valve and somewhat above the impeller of the pump.

The liquid also serves as coolant for the shaft seal. In order to protect the shaft seal the pump must not run dry.



ATTENTION

For safety reasons the pump is only allowed to operate against closed discharge valve for a short time (max. 5 minutes and at a max. temperature of 80°C for standard pumps). Otherwise there is a risk of damage to the pump and, at worst, of a steam explosion. If the pump is not monitored, the installation of a safety device is recommended.

8.1 START-UP

Before starting the pump check that:

- the shaft rotates freely without jarring sounds.
- the pump casing and the suction line are filled with liquid.

Start the pump for a moment to check the direction of rotation. If the direction is correct (i.e. in the direction of the arrow) the pump may be started.

In order to protect the shaft seal the pump must never run dry.

If there is a positive suction lift, open the valve on the suction side of the pump and evacuate the air through the vent plug (5, 25 in rear cover in ESL25/32/40/50-180N). If there is no positive suction lift, the plant must be equipped with a foot valve or a non-return valve on the suction side.

Prime the pump while the vent plug (5, 25 in rear cover in ESL25/32/40/50-180N) is kept open. When the pump has been filled with water, and the air has been evacuated, the system can be started. Check the direction of rotation. If the direction is incorrect interchange 2 of the power cords. The direction of rotation is indicated by an arrow. Make sure the bearings are running correctly and that they do not become warm.

9. SYSTEM BALANCING

It is often difficult to calculate a manometric delivery head in advance. It is, however, decisively important to the quantity of liquid delivered.

A considerably smaller delivery head than expected will increase the quantity of liquid delivered, causing increased power consumption and perhaps cavitation in pump and piping. In the pump the impeller may show signs of heavy erosion caused by cavitation (corrosion) which may at times render an impeller unfit for use in a very short time. Not unusually do similar erosions occur in pipe bends and valves elsewhere in the piping system.

Therefore, after start-up, it is necessary to check either the quantity of liquid delivered or the power consumption of the pump e.g. by measuring the current intensity of the connected motor. Together with a reading of the differential pressure the quantity of water delivered can be determined against the characteristics of the pump.

Should the pump not function as intended, please proceed according to the fault-finding list. Bear in mind, though, that the pump was carefully checked and tested at the factory and that the majority of faults stem from the piping system

| FAULT | CAUSE | REMEDY |
|-------------------------------------|---|---|
| The pump has no or too low capacity | <ol style="list-style-type: none"> 1. Wrong direction of rotation 2. Piping system choked 3. The pump is choked 4. Suction line leaks Pump takes air 5. Suction lift too high 6. Pump and piping system wrongly dimensioned | Change direction of rotation to clockwise when viewed from shaft end (the direction of the arrow) Clean or replace Clean the pump Find the leakage, repair the fault, non-return valve not submerged Check data sheet Q/H curve and NPSH or contact DESMI As 5 |
| The pump uses too much power | <ol style="list-style-type: none"> 1. Counter-pressure too low 2. The liquid is heavier than water 3. Foreign body in pump 4. Electric motor is running on 2 phases | Insert orifice plate or check valve/Contact DESMI Contact DESMI Dismantle the pump, remove the cause Check fuses, cable connection, and cable |
| The pump makes noise | <ol style="list-style-type: none"> 1. Cavitation in pump | Suction lift too high/ Suction line wrongly dimensioned/Liquid temperature too high |

10. INSPECTION AND MAINTENANCE

Inspect the shaft seal for leaks at regular intervals.

- Before inspection of a pump without guard check that the pump cannot be started unintentionally.
- The system is to be without pressure and drained of liquid.
- The repairman must be familiar with the type of liquid which has been pumped as well as the safety measures he is to take when handling the liquid.

On Monobloc pumps, the drain hole at the mechanical shaft seal must be inspected regularly (see drawing example below). Clean the drain hole as needed.

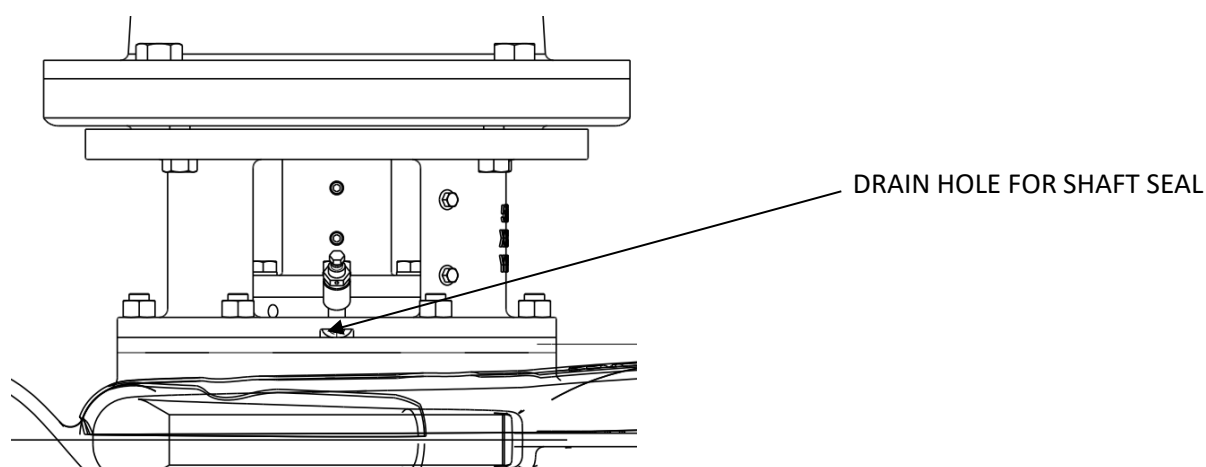

10.1 DRAINING THE PUMP

When the piping system has been drained, note that there is still liquid in the pump. Remove the liquid by dismantling the pipe plug (18) at the bottom of the pump.

11. REPAIRS

11.1 ORDERING SPARE PARTS

When ordering spare parts please always state pump type, serial No. (appears on the name plate of the pump), position No. on the assembly drawing and designation on the spare parts list.

The following parts are exposed to wear: Shaft seal (22,522 in ESL25/32/40/50-180N), impeller (2)/(7)/(5), wear rings (16) and (17) (not including in ESL25-180 and ESL25/32/40/50-180N) and the ball bearings of the motor.

11.2 REPLACING THE IMPELLER

Close the valves on both sides of the pump. Dismantle pipe (29) in ESL25/32/40/50-180N and loosen the nuts (15) and dismantle the top piece from the pump casing. Remove the screw (20, for ESL25/32/40/50-180N is 24) and take off the impeller (2)/(7)/(5). Fit the new impeller.

11.3 REPLACING WEAR RINGS

(Not applicable for ESL 25-180 and ESL25/32/40/50-180N. And ESL40-180 only has a

wear ring in the motor bracket)

When motor and pump have been separated, the wear ring (17) in the pump casing (1) can be pulled out.

In order to replace the upper wear ring (16) it is necessary first to dismantle the impeller. Press the new seal rings into place with an even push all over the face of the ring. Normal diameter difference between seal ring and impeller 0.3-0.4 mm.

11.4 REPLACING SHAFT SEAL (22)

Dismantling as described in paragraph 5.1 or 5.2.

When the impeller has been dismantled, remove the key (19) and then the stop ring (21) (Not applicable for ESL 25-180 and ESL25/32/40/50/65/80/100-180N, ESL80-180N1, ESL65-180M) which is locked with a pointed screw. The sealing element itself can now be pulled off the shaft.

Remove the seat ring from the top piece by pressing with a pair of screwdrivers or the like under the collar off the seat. If the seat cannot be removed, dismantle the top piece from the motor to permit pressing from the back.

Clean the bore for seat and shaft thoroughly of dirt and rust. Remove persistent coatings, if any, by grinding the shaft lightly with very fine emery cloth.

Grease the new seat ring and the inserted O-ring well with glycerine – not oil – and press it into place in the casing. Check that the seat is fitted correctly by knocking lightly with a piece of wood. The seat ring is to be treated very carefully to prevent the sliding surface from being scratched.

It is necessary to use a conical bush as shown below to prevent the rubber bellows from being damaged during mounting.

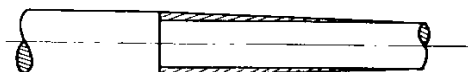

Grease the back of the carbon ring with glycerine to ensure that it stays in its correct place during the mounting. Grease the shaft, the conical bush and the rubber bellows amply with glycerine.

Press the shaft seal on to the shaft until it resists. Press the driving ring only.

Finally place the stop ring (21) (Not applicable for ESL 25-180 and

ESL40/50-180N) on the shaft and lock it with the pointed screw.

When the pump has been mounted, ventilate the pump casing carefully before putting the pump into operation.

When the pump has been running for 1-2 min., ventilate it again, after which it can start normal operation.

Do not forget to check the direction of rotation if there is a risk that the power cords to motor have been exchanged.

11.5 REPLACING BALL BEARINGS IN MOTOR

The ball bearing in the front bearing of the motor can be replaced without disassembling the

pump.

If the ball bearing in the rear bearing of the motor is to be replaced, it is necessary to disassemble the pump and dismantle the pump shaft (as described in paragraph 5.1):

Dismantle the top piece from the motor. Remove the pointed screws (11, 311 in ESL25/32/40/50-180N) in the pump shaft (6,206 in ESL25/32/40/50-180N). The pump shaft can now be pulled off the motor shaft.

When assembling the pump again, check the motor shaft for damages in the form of marks, burrs, or upsetting of the shaft end.

Damages, if any, are to be remedied by means of a file and fine emery cloth. This work has to be done very carefully, especially on new motors, the shaft ends of which are often damaged during transport. If this is not done carefully, the throw will be bigger than permitted and/or the pump shaft will scratch the motor shaft when fitted.

Normally, the pump shaft is to go relatively smoothly on the motor shaft (manually or by means of light strokes with a plastic hammer).

Tighten the pointed screws (the one in the middle first) in accordance with the torque indicated in the table and finally check that the throw stays within the indicated limits by means of an indicator clock.

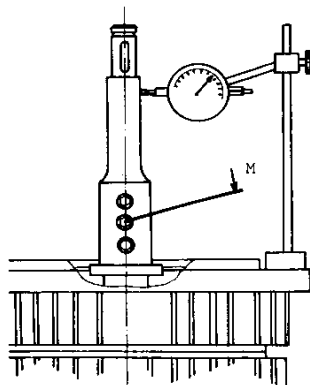

12. OPERATING DATA

The following working pressures (pressure in piping incl. the pressure increase caused by the pump) and number of revolutions are allowed in standard pumps.

| Pump | Max. working pressure[bar] Bronze /Cast iron | Max. working pressure[bar] SG-iron | Max. RPM |
|-----------------------|---|---------------------------------------|----------|
| ESL25-180/180N | 10 | 16 | 3600 |
| ESL32-180N | 10 | 16 | 3600 |
| ESL40-180/180N | 10 | 16 | 3600 |
| ESL50-180/180N | 10 | 16 | 3600 |
| ESL65-180/180M/180N | 10 | 16 | 3600 |
| ESL80-180N/180N1/180E | 10 | 16 | 3600 |
| ESL80-180/180B | 10 | 20 | 3600 |
| ESL100-180/180N | 10 | 16 | 3600 |

The max. working pressure for NiAlBz and stainless steel pumps is 1.5 times max. working pressure for bronze (RG5).

The above-mentioned max. working pressure is a design value – delivered pumps are pressure tested according to actual application requirements and actual flange standards.

For instance the above-mentioned max. working pressure is **NOT** valid for pumps approved by a classification society. Pumps approved by classification societies have been pressure tested according to the requirements of these societies, i.e. a test pressure of 1.5 x the permissible working pressure. The test pressure is stated in the test certificate and stamped into the discharge flange of the pump.

13. EU & UK DECLARATION OF CONFORMITY

DESMI Pumping Technology A/S, hereby declare that our pumps of the ESL Monobloc type are manufactured in conformity with the following essential safety and health requirements in the COUNCIL DIRECTIVE 2006/42/EC on machines, Annex 1.

The following harmonized standards have been used:

| | |
|------------------------------------|---|
| EN/ISO 13857:2019 | Safety of machinery. Safety distances to prevent danger zones being reached by the upper limbs |
| EN 809:1998 + A1:2009 | Pumps and pump units for liquids – Common safety requirements |
| EN12162:2001+A1:2009 | Liquid pumps – Safety requirements – Procedure for hydrostatic testing |
| EN 60204-1:2006/A1:2009 | Safety of machinery – Electrical equipment of machines (item 4, General requirements) |
| Ecodesign Directive (2009/125/EC). | Water pumps: Commission Regulation No 547/2012. Applies only to water pumps marked with the minimum efficiency index MEI. See pump nameplate. |

Pumps delivered by us connected with prime movers are CE-marked and comply with the above requirements.

Pumps delivered by us without prime movers (as partly completed machinery) must only be used when the prime mover and the connection between prime mover and pump comply with the above requirements.

Nørresundby, February 24 2022



Henrik Mørkholt Sørensen
Managing Director

14. INFORMATION RELEVANT FOR DISASSEMBLY OR DISPOSAL AT END-OF-LIFE

No damage materials are used in DESMI pumps – please refer to DESMI Green Passport (can be sent on request – contact a DESMI sales office) – i.e. common recycling companies can handle the disposal at end-of-life. Alternatively the pump and motor can be returned to DESMI at end-of-life for safe recycling.

15. ASSEMBLY DRAWING ESL25-180/-12-COMB.

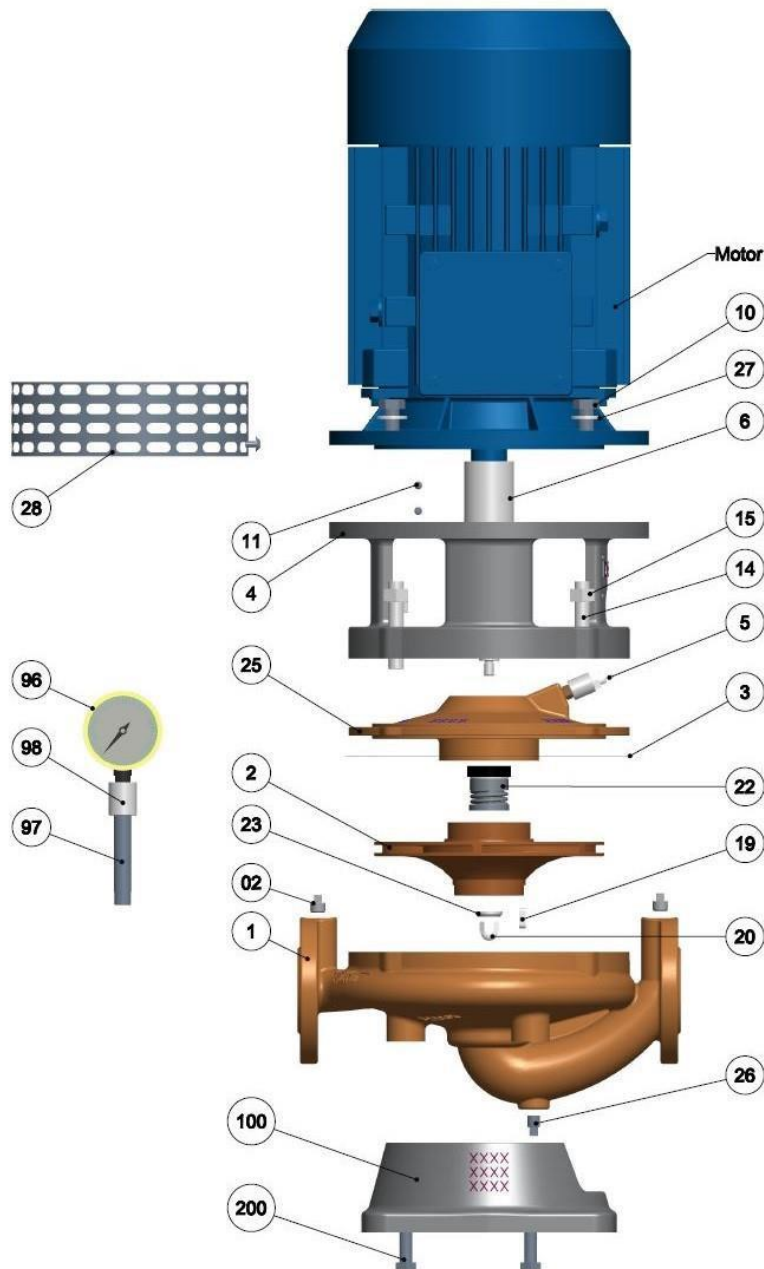

| | |
|-----|-----------------------|
| 1 | Pump casing |
| 2 | Impeller |
| 02 | Plug |
| 3 | Gasket |
| 4 | Motor bracket |
| 5 | Vent plug |
| 6 | Shaft |
| 10 | Set screw |
| 11 | Pointed screw |
| 14 | Stud |
| 15 | Nut |
| 19 | Key |
| 20 | Nut |
| 22 | Mechanical shaft seal |
| 23 | Washer |
| 25 | Cover |
| 26 | Plug |
| 27 | Washer |
| 28 | Guard |
| 96 | Manometer |
| 97 | Nipple |
| 98 | Sleeve |
| 100 | Base plate |
| 200 | Screw |

16. ASSEMBLY DRAWING ESL40-180/-12-COMB.

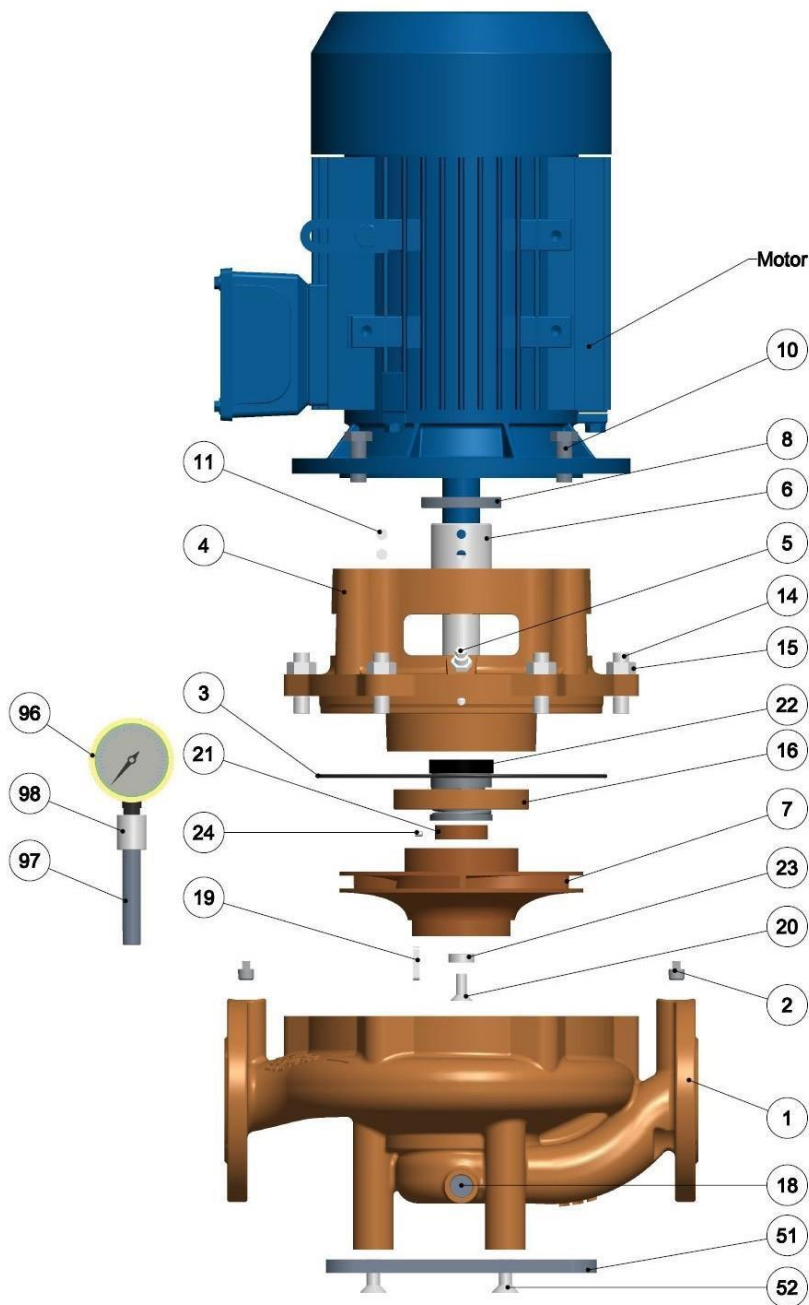

| | |
|----|-----------------------|
| 1 | Pump casing |
| 2 | Plug |
| 3 | O-ring |
| 4 | Casing cover |
| 5 | Vent plug |
| 6 | Shaft |
| 7 | Impeller |
| 8 | Shaft flange |
| 10 | Set screw |
| 11 | Pointed screw |
| 14 | Stud |
| 15 | Nut |
| 16 | Wear ring |
| 18 | Plug |
| 19 | Key |
| 20 | Screw |
| 21 | Stop ring |
| 22 | Mechanical shaft seal |
| 23 | Washer |
| 24 | Pointed screw |
| 51 | Base plate |
| 52 | Screw |
| 96 | Manometer |
| 97 | Nipple |
| 98 | Sleeve |

17. ASSEMBLY DRAWING ESL50-180/-12-COMB.

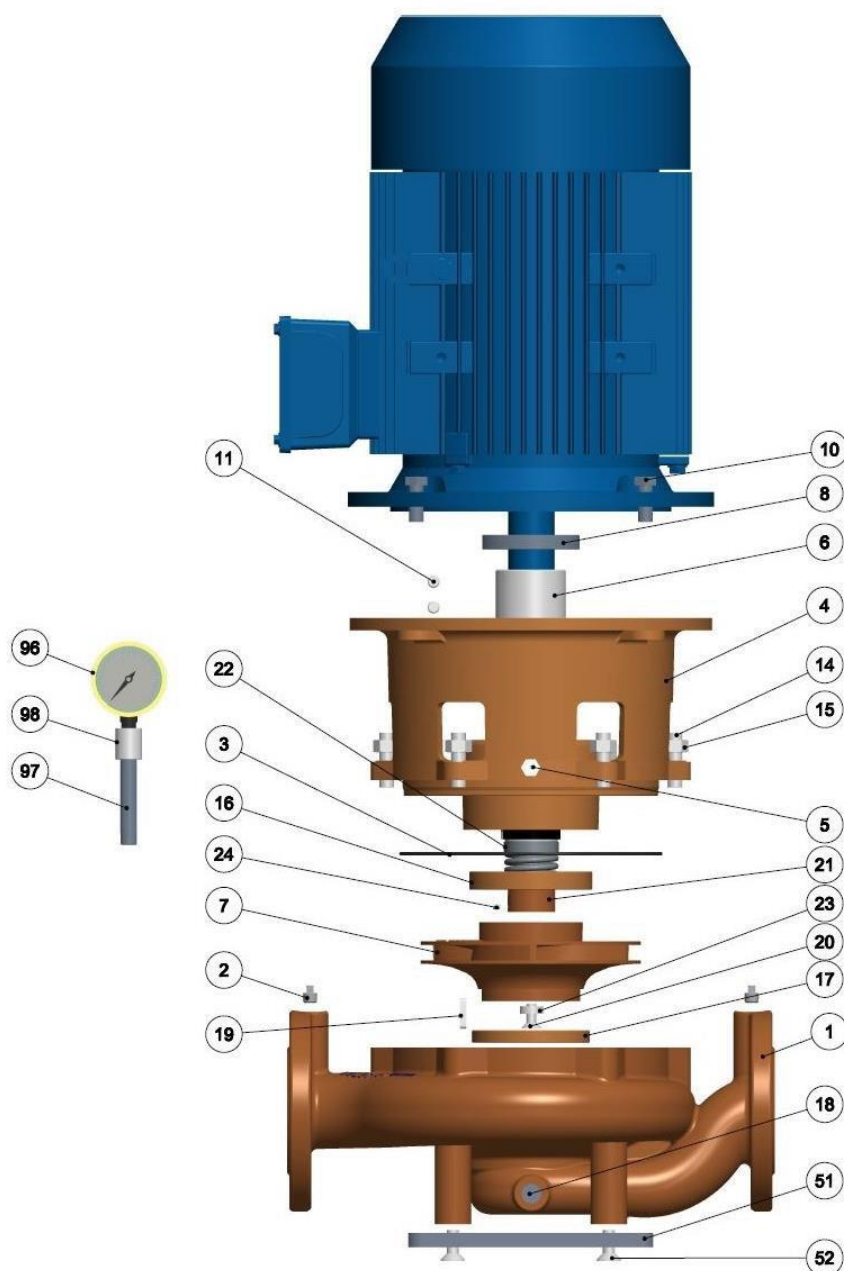

| | |
|----|-----------------------|
| 1 | Pump casing |
| 2 | Plug |
| 3 | O-ring |
| 4 | Casing cover |
| 5 | Vent plug |
| 6 | Shaft |
| 7 | Impeller |
| 8 | Shaft flange |
| 10 | Set screw |
| 11 | Pointed screw |
| 14 | Stud |
| 15 | Nut |
| 16 | Wear ring |
| 17 | Wear ring |
| 18 | Plug |
| 19 | Key |
| 20 | Screw |
| 21 | Stop ring |
| 22 | Mechanical shaft seal |
| 23 | Washer |
| 24 | Pointed screw |
| 51 | Base plate |
| 52 | Screw |
| 96 | Manometer |
| 97 | Nipple |
| 98 | Sleeve |

18. ASSEMBLY DRAWING ESL65-180/-12-COMB.

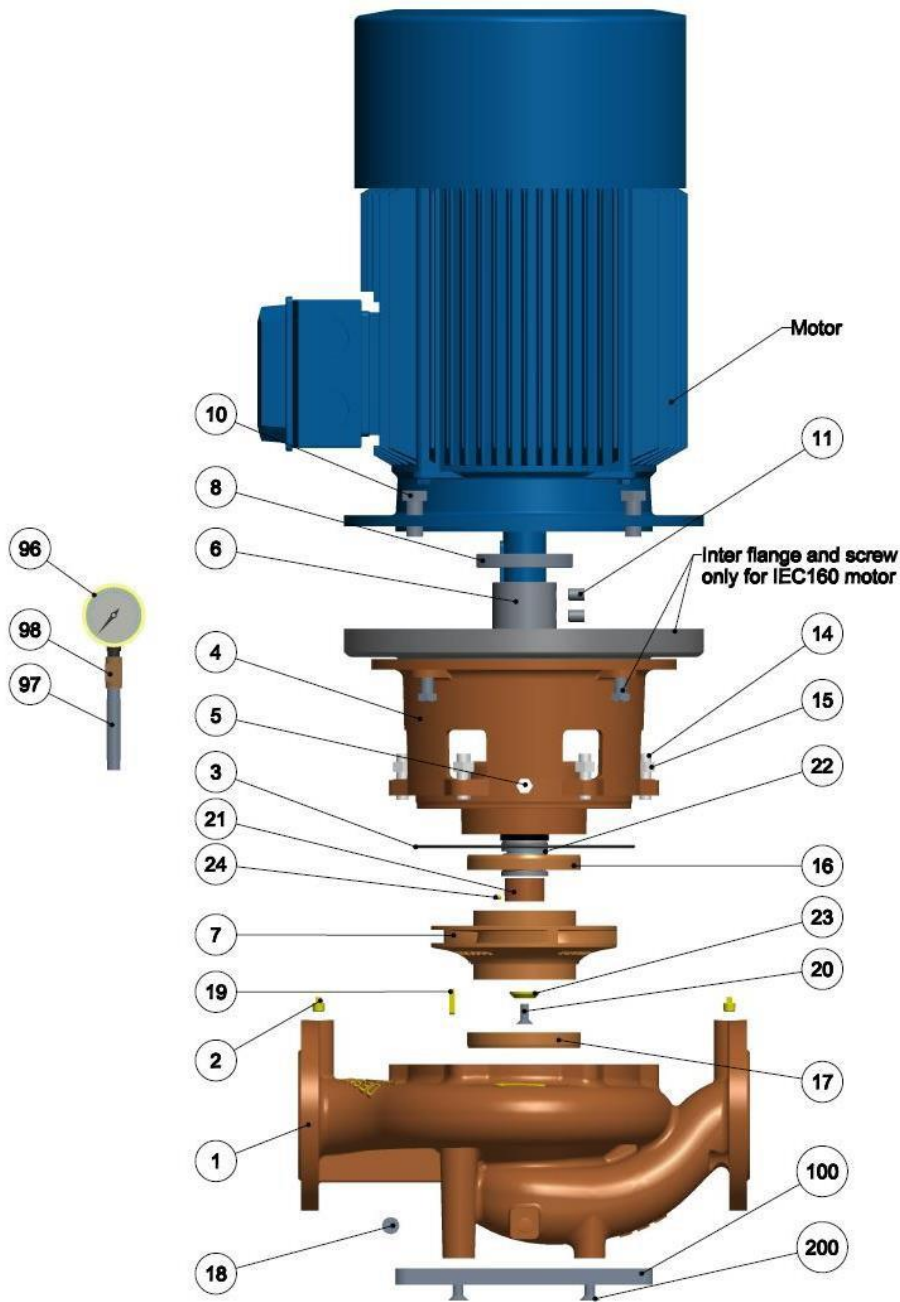

| | |
|-----|-----------------------|
| 1 | Pump casing |
| 2 | Plug |
| 3 | O-ring |
| 4 | Casing cover |
| 5 | Vent plug |
| 6 | Shaft |
| 7 | Impeller |
| 8 | Shaft flange |
| 10 | Set screw |
| 11 | Pointed screw |
| 14 | Stud |
| 15 | Nut |
| 16 | Wear ring |
| 17 | Wear ring |
| 18 | Plug |
| 19 | Key |
| 20 | Screw |
| 21 | Stop ring |
| 22 | Mechanical shaft seal |
| 23 | Washer |
| 24 | Pointed screw |
| 96 | Manometer |
| 97 | Nipple |
| 98 | Sleeve |
| 100 | Base plate |
| 200 | Screw |

19. ASSEMBLY DRAWING ESL80-180/-12 & ESL80-180B/-12 & ESL80-180E/-12 -COMB.

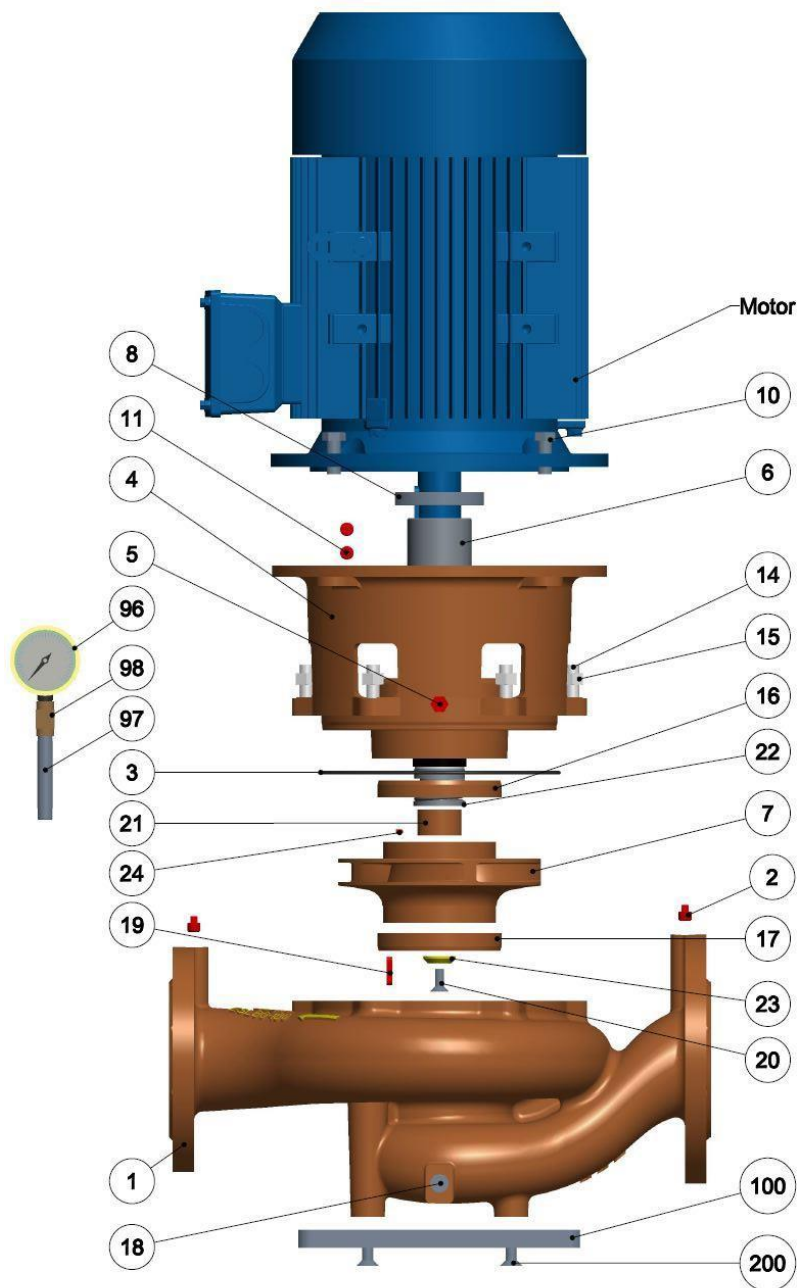

| | |
|-----|-----------------------|
| 1 | Pump casing |
| 2 | Plug |
| 3 | O-ring |
| 4 | Casing cover |
| 5 | Vent plug |
| 6 | Shaft |
| 7 | Impeller |
| 8 | Shaft flange |
| 10 | Set screw |
| 11 | Pointed screw |
| 14 | Stud |
| 15 | Nut |
| 16 | Wear ring |
| 17 | Wear ring |
| 18 | Plug |
| 19 | Key |
| 20 | Screw |
| 21 | Stop ring |
| 22 | Mechanical shaft seal |
| 23 | Washer |
| 24 | Pointed screw |
| 96 | Manometer |
| 97 | Nipple |
| 98 | Sleeve |
| 100 | Base plate |
| 200 | Screw |

20. ASSEMBLY DRAWING ESL100-180/-12-COMB.

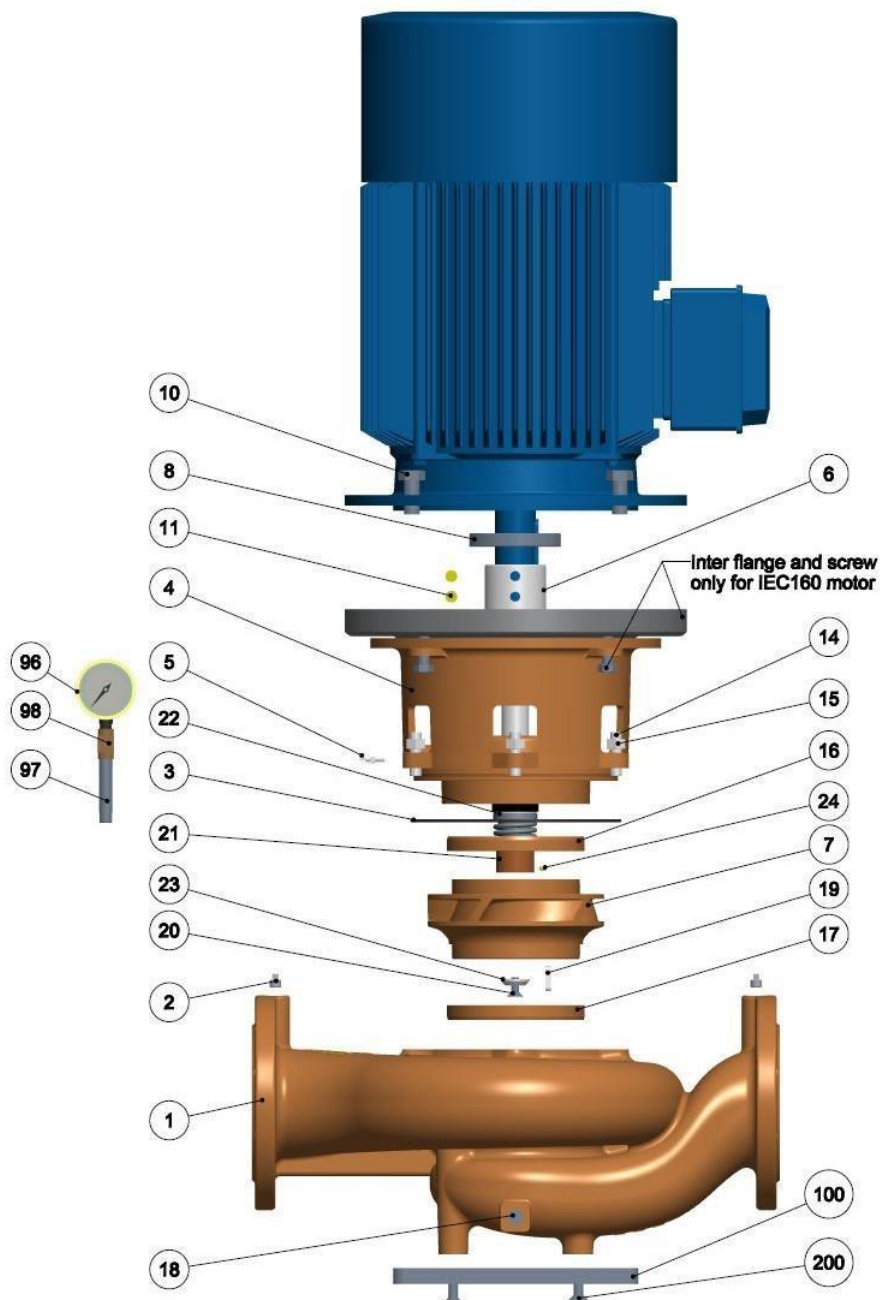

| | |
|-----|-----------------------|
| 1 | Pump casing |
| 2 | Plug |
| 3 | O-ring |
| 4 | Casing cover |
| 5 | Vent plug |
| 6 | Shaft |
| 7 | Impeller |
| 8 | Shaft flange |
| 10 | Set screw |
| 11 | Pointed screw |
| 14 | Stud |
| 15 | Nut |
| 16 | Wear ring |
| 17 | Wear ring |
| 18 | Plug |
| 19 | Key |
| 20 | Screw |
| 21 | Stop ring |
| 22 | Mechanical shaft seal |
| 23 | Washer |
| 24 | Pointed screw |
| 96 | Manometer |
| 97 | Nipple |
| 98 | Sleeve |
| 100 | Base plate |
| 200 | Screw |

21.ASSEMBLY DRAWING ESL25/32/40/50-180N/-12-COMB

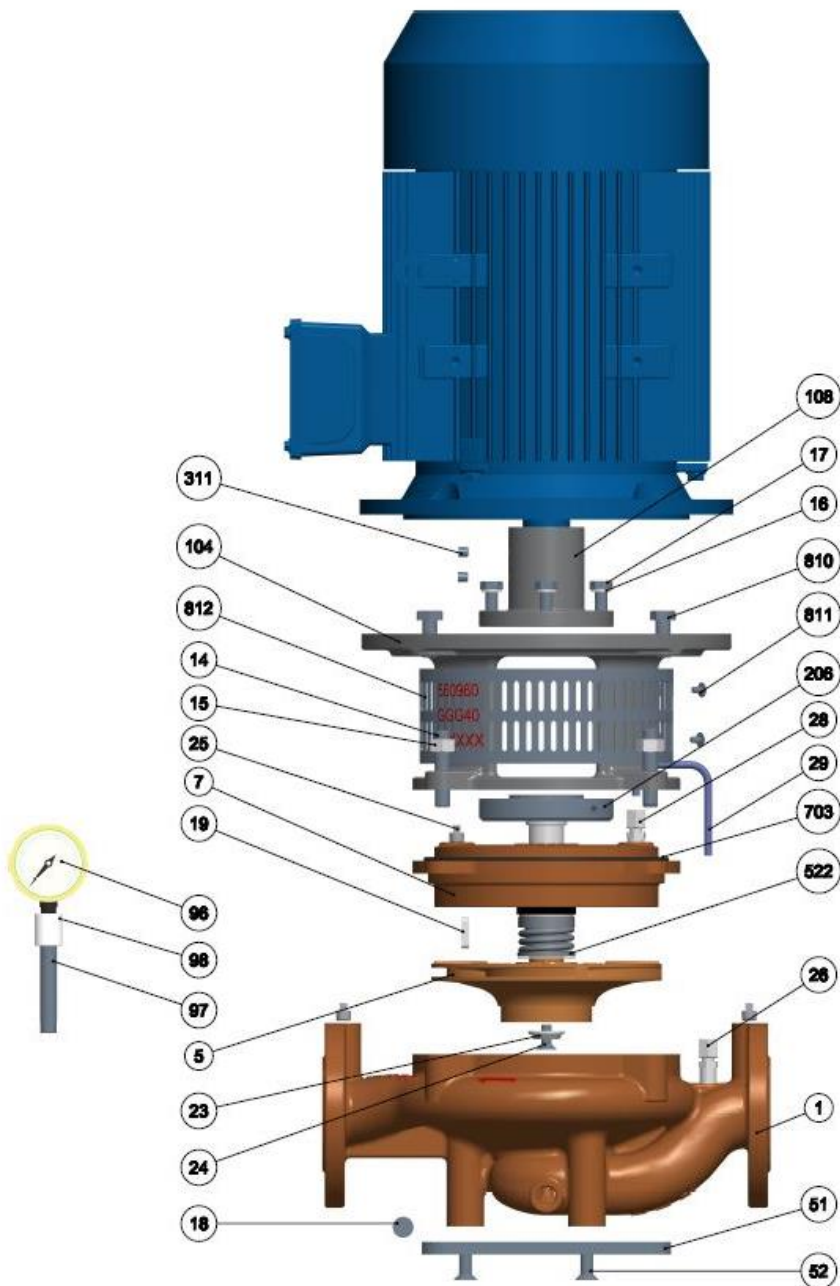

| | |
|-----|-----------------|
| 1 | Pump casing |
| 5 | Impeller |
| 7 | Rear cover |
| 14 | Stud |
| 15 | Nut |
| 16 | Washer |
| 17 | Set screw |
| 18 | Plug |
| 19 | Key |
| 23 | Washer |
| 24 | Screw |
| 25 | Plug |
| 26 | Nipple |
| 28 | Nipple |
| 29 | Pipe |
| 51 | Base plate |
| 52 | Screw |
| 96 | Manometer |
| 97 | Nipple |
| 98 | Sleeve |
| 104 | Motor bracket |
| 108 | Motor coupling |
| 206 | Shaft W. Flange |
| 311 | Pointed screw |
| 522 | Shaft seal |
| 703 | O-ring |
| 810 | Set screw |
| 811 | BH-Screw |
| 812 | Guard |

22.ASSEMBLY DRAWING ESL65/80/100-180N/-12 & ESL80-180N1& ESL65-180M/-12-COMB

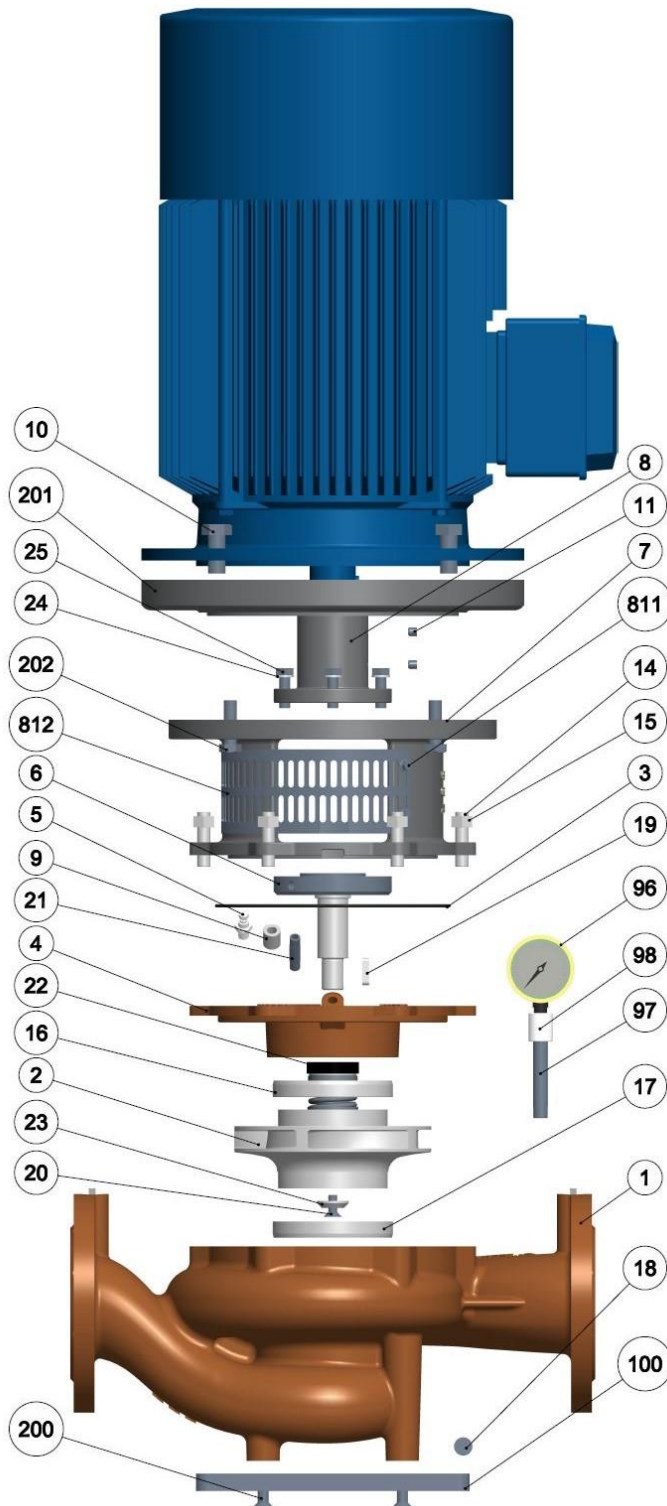

| | |
|-----|-----------------|
| 1 | Pump casing |
| 2 | Impeller |
| 3 | O-ring |
| 4 | Rear cover |
| 5 | Venting plug |
| 6 | Shaft W. Flange |
| 7 | Motor bracket |
| 8 | Motor coupling |
| 9 | Muff |
| 10 | Set screw |
| 11 | Pointed screw |
| 14 | Stud |
| 15 | Nut |
| 16 | Wear ring |
| 17 | Wear ring |
| 18 | Plug |
| 19 | Key |
| 20 | Set screw |
| 21 | Sleeve |
| 22 | Shaft seal |
| 23 | Washer |
| 24 | Washer |
| 25 | Set screw |
| 96 | Manometer |
| 97 | Nipple |
| 98 | Sleeve |
| 100 | Base plate |
| 200 | Screw |
| 201 | Inter. flange |
| 202 | Set screw |
| 811 | BH-Screw |
| 812 | Guard |

23.DIMENSIONAL SKETCH ESL

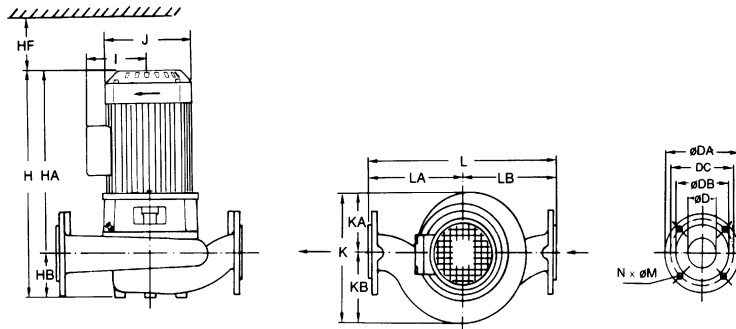

| | Type | TN | Flange | D mm | DA mm | DB mm | DC mm | H Max. mm | HA Max. mm | HB mm | HF Min. mm | I Max. mm | J Max. mm | K mm | KA mm | KB mm | L mm | LA mm | LB mm | N x M mm |
|----|--|----|-----------------|---------|----------|----------|----------|-----------------|------------------|----------|------------------|-----------------|-----------------|---------|----------|----------|---------|----------|----------|-------------|
| 1 | ESL25- 180 | 10 | 1" 25 mm | 25 | 115 | 68 | 85 | 754 | 644 | 110 | 60 | 240 | 275 | 220 | 110 | 110 | 300 | 150 | 150 | 4xø14 |
| 2 | ESL25- 180N | 10 | 1" 25 mm | 25 | 115 | 68 | 85 | 755 | 645 | 110 | 60 | 240 | 275 | 220 | 110 | 110 | 300 | 150 | 150 | 4xø14 |
| 3 | ESL32- 180N | 10 | 1 1/4" 32 mm | 32 | 140 | 78 | 100 | 755 | 645 | 110 | 60 | 240 | 275 | 225 | 108 | 117 | 320 | 160 | 160 | 4xø18 |
| 2 | ESL40-180N | 10 | 1 1/2" 40 mm | 40 | 150 | 90 | 110 | 878 | 778 | 100 | 60 | 285 | 320 | 244 | 116 | 128 | 360 | 180 | 180 | 4xø18 |
| 3 | ESL40- 180 | 10 | 1 1/2" 40 mm | 40 | 150 | 90 | 110 | 960 | 840 | 120 | 60 | 285 | 320 | 253 | 118 | 135 | 350 | 175 | 175 | 4xø18 |
| 4 | ESL50-180N | 10 | 2" 50 mm | 50 | 165 | 102 | 125 | 878 | 780 | 98 | 60 | 285 | 320 | 260 | 123 | 137 | 400 | 200 | 200 | 4xø18 |
| 5 | ESL50- 180 | 10 | 2" 50 mm | 50 | 165 | 102 | 125 | 935 | 830 | 105 | 60 | 285 | 320 | 267 | 145 | 122 | 400 | 200 | 200 | 4xø18 |
| 6 | ESL65- 180 ESL65-180M ESL65-180N | 10 | 2 1/2" 65 mm | 65 | 185 | 122 | 145 | 878 | 828 | 155 | 100 | 285 | 320 | 295 | 137 | 158 | 440 | 220 | 220 | 4xø18 |
| 8 | ESL80- 180 ESL180-180B | 10 | 3" 80 mm | 80 | 200 | 138 | 160 | 966 | 830 | 136 | 120 | 285 | 320 | 320 | 150 | 170 | 480 | 240 | 240 | 8xø18 |
| 9 | ESL80- 180N ESL80-180N1 ESL80-180E | 10 | 3" 80 mm | 80 | 200 | 138 | 160 | 990 | 830 | 160 | 120 | 285 | 320 | 310 | 140 | 170 | 480 | 240 | 240 | 8xø18 |
| 12 | ESL100- 180 ESL100-180N | 10 | 4" 100mm | 100 | 220 | 158 | 180 | 1003 | 833 | 170 | 140 | 285 | 320 | 350 | 160 | 190 | 540 | 270 | 270 | 8xø18 |

Table with thread sizes of manometer, drain and vent plug hole (if any) on the next page.

| | Type | Manometer | Drain | Air vent |
|----|--------------|-----------|-------|----------|
| 1 | ESL25-180 | 1/4" | 1/8" | 1/8" |
| 2 | ESL25-180N | 1/4" | 3/8" | 1/4" |
| 3 | ESL32-180N | 1/4" | 3/8" | 1/4" |
| 4 | ESL40-180N | 1/4" | 3/8" | 1/4" |
| 5 | ESL40-180 | 1/4" | 3/8" | 1/8" |
| 6 | ESL50-180N | 1/4" | 3/8" | 1/4" |
| 7 | ESL50-180 | 1/4" | 3/8" | 1/8" |
| 8 | ESL65-180 | 1/4" | 3/8" | 1/8" |
| 9 | ESL65-180M/N | 1/4" | 3/8" | 1/8" |
| 10 | ESL80-180 | 1/4" | 3/8" | 1/8" |
| 11 | ESL80-180N | 1/4" | 3/8" | 1/8" |
| 12 | ESL80-180N1 | 1/4" | 3/8" | 1/8" |
| 13 | ESL80-180B | 1/4" | 3/8" | 1/8" |
| 14 | ESL80-180E | 1/4" | 3/8" | 1/8" |
| 15 | ESL100-180 | 1/4" | 3/8" | 1/8" |
| 16 | ESL100-180N | 1/4" | 3/8" | 1/8" |