

OPERATION AND MAINTENANCE INSTRUCTIONS

DESMI two-stage vertical centrifugal pump

TSL Monobloc

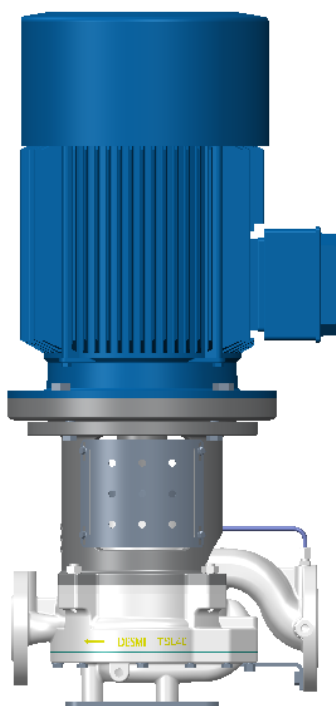

DESMI Pumping Technology A/S

Tagholm I, DK-9400 Nørresundby, Denmark

Manual: T1541	Language: English	Revision: B(1/2023)
------------------	----------------------	------------------------

Special pump No.

Table of Contents

1. PRODUCT DESCRIPTION	3
1.1 DELIVERY	3
2. TECHNICAL DATA	3
2.1 EXPLANATION OF THE TYPE NUMBER	3
2.2 TECHNICAL DESCRIPTION	4
3. INSTALLATION.....	5
3.1 MOUNTING/FASTENING	5
3.2 WIRING.....	5
4. TRANSPORT/STORAGE.....	6
5. DISMANTLING	7
5.1 DISMANTLING OF TSL40/50-180	7
5.2 INSPECTION	9
6. ASSEMBLING	10
6.1 FITTING SEALING RINGS	10
6.2 FITTING SHAFT SEAL	10
6.3 FITTING IMPELLERS.....	10
6.4 FITTING SHAFT SEAL COVER	10
6.5 FITTING MOTOR	10
6.6 SHAFT	11
7. FROST PROTECTION	11
8. START-UP	11
8.1 START-UP	11
9. SYSTEM BALANCING	12
10. INSPECTION AND MAINTENANCE.....	13
10.1 DRAINING THE PUMP	13
11. REPAIRS	13
11.1 ORDERING SPARE PARTS	13
11.2 REPLACING THE IMPELLER.....	13
11.3 REPLACING SEAL RINGS	13
11.4 REPLACING SHAFT SEAL (10)	13
11.5 REPLACING BALL BEARINGS IN MOTOR.....	14
12. OPERATING DATA	14
13. EU DECLARATION OF CONFORMITY	16
14. INFORMATION RELEVANT FOR DISASSEMBLY OR DISPOSAL AT END-OF-LIFE	17
15. ASSEMBLY DRAWING TSL40/50-180/-12.....	17
16. DIMENSIONAL SKETCH	19

1. PRODUCT DESCRIPTION

These operation and maintenance instructions apply to the DESMI TSL Monobloc pump for vertical mount.

The pump is a two-stage vertical centrifugal pump equipped with stainless steel shaft, mechanical shaft seal, and closed impeller.

The pump is suitable for the pumping of liquids with temperatures up to 80°C. With special shaft seal up to 140°C in Monobloc pumps without bearing (/12 design). For pumping of liquids with temperatures above 100°C DESMI recommends using only ductile iron (for instance GGG40) for pump casing and rear cover. Max. working pressure and number of revolutions are indicated under Operating Data.

1.1 DELIVERY

- Check on delivery that the shipment is complete and undamaged.
- Defects and damages, if any, to be reported to the carrier and the supplier immediately in order that a claim can be advanced.

2. TECHNICAL DATA

The pumps are manufactured in various material combinations which appear from the type number on the name plate. See below.

2.1 EXPLANATION OF THE TYPE NUMBER

All the TSL pumps are provided with a name plate. The type number indicated on the name plate is built up as follows:

TSLXXX-YYY-MR

XXX: Pressure branch diameter, YYY: Standard impeller diameter

M: The material combination of the pump.

R: The assembly combination of the pump.

M may be the following:

A: Casing and shaft seal cover : Cast iron + cast iron alloy. Impeller and sealing rings: NIALBZ

D: Casing and shaft seal cover: NIALBZ. Impeller and sealing rings: NIALBZ

S: Casing, shaft seal cover, impeller and sealing rings: SAF2507 and stainless steel alloy

E: Special materials

U: Nonmagnetic material

The pumps can be delivered in other material combinations according to agreement with the supplier.

R may be the following:

12: Monobloc, without bearing in the pump

Any use of the pump is to be evaluated on the basis of the materials used in the pump. In case of doubt, contact the supplier.

Pumps in material combinations A are primarily used for fresh water.
 Pumps in material combination D are primarily used for seawater.
 If the pumps are designed for special purposes the following is to be indicated:

Pump No. :
 Pump type :
 Application :
 Comment :

2.2 TECHNICAL DESCRIPTION

The noise level indicated is the airborne noise including the motor. The noise depends on the motor type supplied, as the noise from the pump can be calculated as the noise level of the motor + 2dB(A). The noise level is for pumps with electric motors.

The capacity of the pump appears from the name plate on the pump. If the pump has been delivered without motor, the pump capacity is to be indicated on the plate when mounting the motor.

The permissible loads on the flanges appear from the following table. For pumps in SG iron (GGG40) and NiAlBz the values are to be increased by factor 1.5.

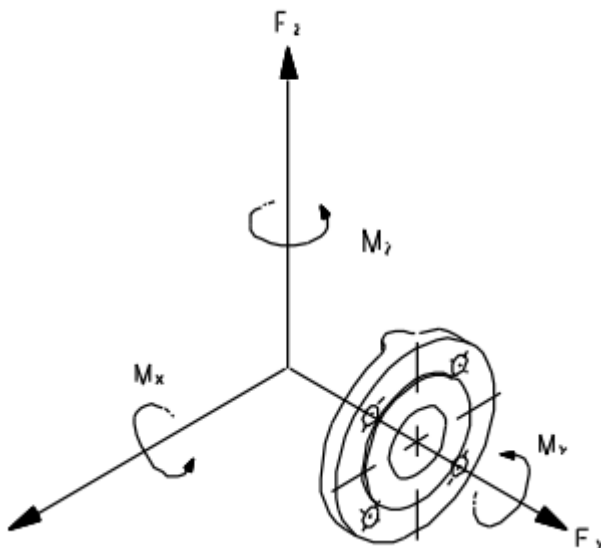

DN mm	Forces (N)				Torques (Nm)			
	F _y	F _z	F _x	∑F	M _y	M _z	M _x	∑M
40	400	500	400	750	400	200	300	550
50	500	600	550	1000	450	250	350	600
65	650	840	750	1340	510	310	380	700

In connection with the permissible loads on the flanges the following is to be observed:

$$\left(\frac{\Sigma F_{\text{calculated}}}{\Sigma F_{\text{Max.permissible}}} \right)^2 + \left(\frac{\Sigma M_{\text{calculated}}}{\Sigma M_{\text{Max.permissible}}} \right)^2 < 2$$

where index "calc" is the values calculated by the user.

At the same time none of the forces or moments may exceed the indicated figure multiplied by 1.4.

3. INSTALLATION

3.1 MOUNTING/FASTENING

Insert the pump in the pipeline in the same way as a valve. The pump can be inserted in both horizontal and vertical pipes, but not in a horizontal pipe if the motor is placed below horizontal level. The max. loads on the flanges appear from the technical description.

When installing the pump check that it is earthed to avoid an electrical potential in the pump.

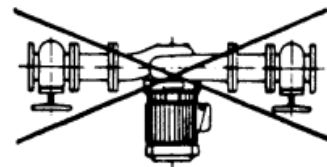
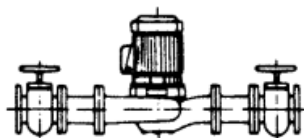
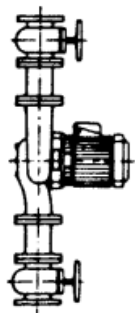

The max. permissible loads on the flanges stated in paragraph 2.2 are to be observed.

At installations pumping hot or very cold liquids, the operator must be aware that it is dangerous to touch the pump surface and, consequently, he must take the necessary safety measures.

3.2 WIRING



Wiring to be carried out by authorised skilled workmen according to the rules and regulations in force.

4. TRANSPORT/STORAGE

The weights of the pumps in A and D combination (without motor) are stated in the following table, and the pumps are to be lifted as shown below.

Pump	Weight in kg A12 / D12 comb. without base plate
TSL 40-180	58/63
TSL 50-180	64/70

The pump is to be stored in a dry area.
Before shipment the pump is to be fastened securely on pallets or the like.

The pump is to be lifted in the following way:

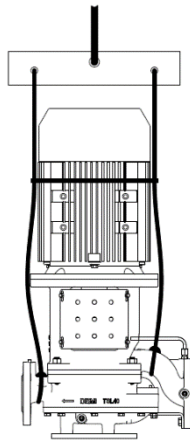

The lifting straps must not bear against sharp edges and corners.

5. DISMANTLING



Before dismantling the pump make sure that it has stopped. Empty the pump of liquid before it is dismantled from the piping system. If the pump has been pumping dangerous liquids you are to be aware of this and take the necessary safety measures.

If the pump has been pumping hot liquids, take great care that it is drained before it is removed from the piping system.

5.1 DISMANTLING OF TSL40/50-180



Before dismantling



1. Remove hex bolts(45) and coupling guard(44)



2. Remove screws(37)



3. Loose set screws (42) ;
Remove motor



4. Loose Allen screw(36) ;Remove thrust plate(35)

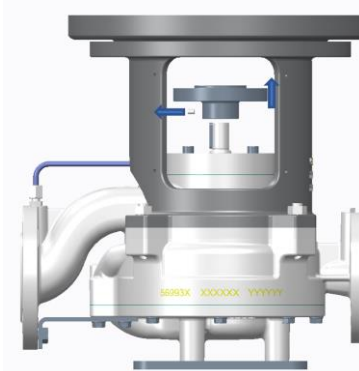

5. Loose Allen screw(34) ;Remove pump hub(33)

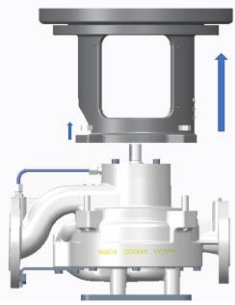

6. Loose nuts (31) ;Remove motor bracket(47)

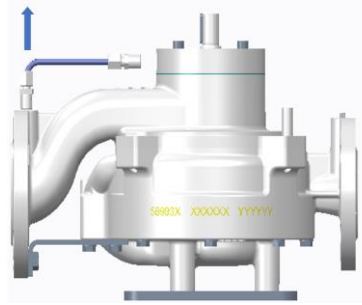

7. Remove sealing flush pipe;

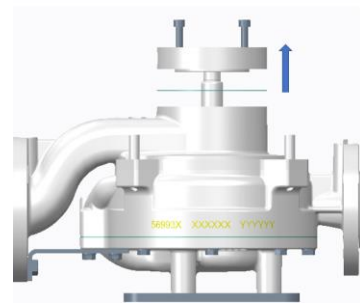

8. Loose Allen screw(25) ;Remove seal cover (28)

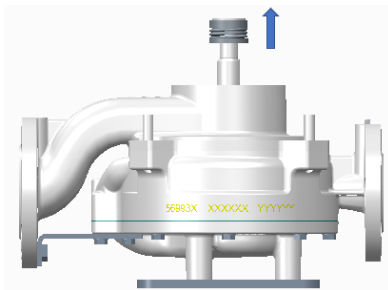

9. Remove shaft seal(10)

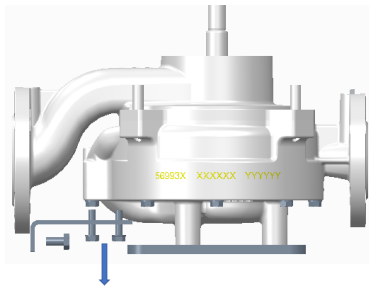

10. Loose set screw (16&29);remove support (19)



11.Remove inlet cover(3)

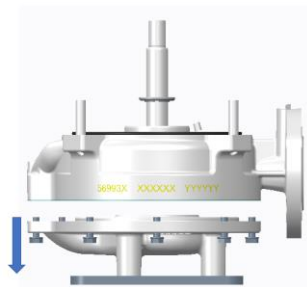

12.Loose hex bolt (17); Remove case suction(9)

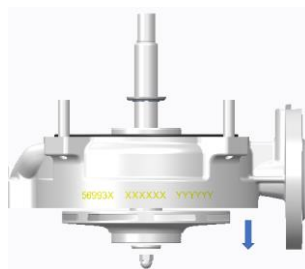

13.Loose cap nut (13) and washer (14&15), remove impeller

5.2 INSPECTION

When the pump has been dismantled, check the following parts for wear and damage:

- Sealing ring/impeller/mid seal ring: Max. clearance 0.3-0.6 mm measured in radius.
- Shaft seal/shaft seal cover : Check the seat for flatness and cracks.
Check the rubber parts for elasticity.

6. ASSEMBLING

Refer to the reverse process of dismantling.

6.1 FITTING SEALING RINGS

When fitted the wear ring(4) is to bear against the shoulder of the casing suction (9).

When fitted the wear ring (7) is to bear against the shoulder of the inlet cover (3).

When fitted the wear ring (8) is to bear against the shoulder of the casing volute (1).

6.2 FITTING SHAFT SEAL

Before fitting the seat, clean the recess in the shaft seal cover. When fitting the seat, remove the protective coating without scratching the lapped surface. And lubricate the outer rubber L-ring of the seat with a thin layer of silicone grease. Use a brush and ensure that no silicone grease ends up at the slide surface. Now press the seat into place with the fingers and check that all parts are correctly imbedded.

If it is necessary to use tools for assembling, then protect the sliding surface of the seat to prevent it from being scratched or cut. Lubricate the inner surface of the slide ring rubber bellows with a thin layer of silicone grease (ensure that no silicone grease ends up at the slide surfaces) and push it over the shaft. The use of a conical fitting bush is recommended to avoid that the rubber bellows is cut.

Push the slide ring over the shaft with the hand. If the rubber bellows is tight, use a fitting tool and take care that the slide ring is not damaged. If the carbon ring is not fixed, it is important to check that it is fitted correctly, i.e. the chamfered/lapped side is to face the seat. The carbon ring can be held by a little grease.

When using silicone grease on the shaft, the bellows will settle and seat in abt. 15 minutes, and until then tightness should not be expected. After start, check by viewing the leak hole that there are no leaks.

6.3 FITTING IMPELLERS

Fit the sunk key(23) in the shaft(48) and push the top impeller(6) towards shaft shoulder(48); Assemble casing volute (1) ;

Lead the bottom impeller towards top impeller. Secure the bottom impeller with washers (14) and a cap nut(13).

6.4 FITTING SHAFT SEAL COVER

Place the gasket between inlet cover and shaft seal cover . Fit and fasten shaft seal cover in the inlet cover.

6.5 FITTING MOTOR

Fit the motor coupling (39) to motor shaft and tighten the pointed screw (40) slightly, place motor onto bracket (41) and tighten the set screw (42). Add 2 shims (301) between motor coupling (8) and pump hub flange (6), adjust the motor coupling to make it resist on the shims to ensure it is at the right axial position. Tighten the pointed screw (11) and remove the shims (301). Tighten the set screw (37) to lift up the impeller to a right position.

See table below regarding tightening torque of pointed screws (40).

Motor Size	Dimension Point Screws	Torque Pointed Screws
71/80	M6	10Nm
90/100/112/132/160/180	M8	24Nm

6.6 SHAFT

When the pump has been assembled, check that the shaft rotates freely.

7. FROST PROTECTION

Pumps which are not in operation during frost periods are to be drained to avoid frost damage. Remove the plug at the bottom to empty the pump. Alternatively, it is possible to use anti-freeze liquids in normal constructions.

8. START-UP



A centrifugal pump will not function until it has been filled with liquid between the foot valve and somewhat above the impeller of the pump.

The liquid also serves as coolant for the shaft seal. In order to protect the shaft seal the pump must not run dry.

ATTENTION

For safety reasons the pump is only allowed to operate against closed discharge valve for a short time (max. 5 minutes and at a max. temperature of 80°C for standard pumps).

Otherwise there is a risk of damage to the pump and, at worst, of a steam explosion. If the pump is not monitored, the installation of a safety device is recommended.

8.1 START-UP

Before starting the pump check that:

- the shaft rotates freely without jarring sounds.
- the pump casing and the suction line are filled with liquid.

Start the pump for a moment to check the direction of rotation. If the direction is correct (i.e. in the direction of the arrow) the pump may be started.

In order to protect the shaft seal the pump must never run dry.

If there is a positive suction lift, open the valve on the suction side of the pump and evacuate the air. If there is no positive suction lift, the plant must be equipped with a foot valve or a non-return valve on the suction side.

Prime the pump before starting. When the pump has been filled with water, and the air has been evacuated, the system can be started. Check the direction of rotation. If the direction is incorrect interchange 2 of the power cords. The direction of rotation is indicated by an arrow. Make sure the bearings are running correctly and that they do not become warm.

9. SYSTEM BALANCING

It is often difficult to calculate a manometric delivery head in advance. It is, however, decisively important to the quantity of liquid delivered.

A considerably smaller delivery head than expected will increase the quantity of liquid delivered, causing increased power consumption and perhaps cavitation in pump and piping. In the pump the impeller may show signs of heavy erosion caused by cavitation (corrosion) which may at times render an impeller unfit for use in a very short time. Not unusually do similar erosions occur in pipe bends and valves elsewhere in the piping system.

Therefore, after start-up, it is necessary to check either the quantity of liquid delivered or the power consumption of the pump e.g. by measuring the current intensity of the connected motor. Together with a reading of the differential pressure the quantity of water delivered can be determined against the characteristics of the pump.

Should the pump not function as intended, please proceed according to the fault-finding list. Bear in mind, though, that the pump was carefully checked and tested at the factory and that the majority of faults stem from the piping system

FAULT	CAUSE	REMEDY
The pump has no or too low capacity	<ol style="list-style-type: none"> 1. Wrong direction of rotation 2. Piping system choked 3. The pump is choked 4. Suction line leaks Pump takes air 5. Suction lift too high 6. Pump and piping system wrongly dimensioned 	Change direction of rotation to clockwise when viewed from shaft end (the direction of the arrow) Clean or replace Clean the pump Find the leakage, repair the fault, non-return valve not submerged Check data sheet Q/H curve and NPSH or contact DESMI As
The pump uses too much power	<ol style="list-style-type: none"> 1. Counter-pressure too low 2. The liquid is heavier than water 3. Foreign body in pump 4. Electric motor is running on 2 phases 	Insert orifice plate or check valve/Contact DESMI Contact DESMI Dismantle the pump, remove the cause Check fuses, cable connection, and cable
The pump makes noise	<ol style="list-style-type: none"> 1. Cavitation in pump 	Suction lift too high/ Suction line wrongly dimensioned/Liquid temperature too high

10. INSPECTION AND MAINTENANCE

Inspect the shaft seal for leaks at regular intervals.

- Before inspection of a pump without guard check that the pump cannot be started unintentionally.
- The system is to be without pressure and drained of liquid.
- The repairman must be familiar with the type of liquid which has been pumped as well as the safety measures he is to take when handling the liquid.

10.1 DRAINING THE PUMP

When the piping system has been drained, note that there is still liquid in the pump. Remove the liquid by dismantling the pipe plug at the bottom of the pump.

11. REPAIRS

11.1 ORDERING SPARE PARTS

When ordering spare parts please always state pump type, serial No. (appears on the name plate of the pump), position No. on the assembly drawing and designation on the spare parts list.

The following parts are exposed to wear: Shaft seal (10), impeller (5)/(6), seal rings (4, 7 and 8) and the ball bearings of the motor.

11.2 REPLACING THE IMPELLER

Close the valves on both sides of the pump. Loose the nuts (16&17) and dismantle the casing suction from the casing volute. Remove the cap nut (13) and take off the bottom impeller (5).

Loose nuts(32) , remove casing volute (1) and top impeller (6).

Fit new top impeller (6), assemble casing volute and then fit bottom impeller (5) , secure bottom impeller (5) with washers (15&14) and a cap nut (13).

11.3 REPLACING SEAL RINGS

Dismantle the casing suction and casing volute, the seal ring (4,7,8) can be dismantled.

In order to replace the upper seal ring (7) it is necessary first to dismantle the impellers and casing volute.

Press the new seal rings (4,7,8) into place with an even push all over the face of the ring. Normal diameter difference between seal ring and impeller 0.3-0.4 mm.

11.4 REPLACING SHAFT SEAL (10)

Dismantling as described in paragraph 5.1.

When the motor with motor hub has been dismantled, remove Allen screw (36) and loose Allen screw(34) . Remove pump hub (33).Remove set screws (25) and then sealing cover (28).The sealing element can now be pulled off the shaft.

Clean the bore for seat and shaft thoroughly of dirt and rust. Remove persistent coatings, if any, by grinding the shaft lightly with very fine emery cloth.

Grease the new seat ring and the inserted O-ring well with glycerine – not oil – and press it into place . Check that the seat is fitted correctly by knocking lightly with a piece of wood. The seat ring is to be treated very carefully to prevent the sliding surface from being scratched.

It is necessary to use a conical bush as shown below to prevent the rubber bellows from being damaged during mounting.

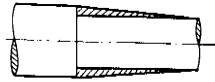

Grease the back of the carbon ring with glycerine to ensure that it stays in its correct place during the mounting. Grease the shaft, the conical bush and the rubber bellows amply with glycerine.

Press the shaft seal on to the shaft until it resists. Press the driving ring only,

Do not forget to check the direction of rotation if there is a risk that the power cords to motor have been exchanged.

11.5 REPLACING BALL BEARINGS IN MOTOR

The ball bearing in the front bearing of the motor can be replaced without disassembling the pump.

If the ball bearing in the rear bearing of the motor is to be replaced, it is necessary to disassemble motor from the whole pump.

Remove coupling guard (44) and remove screws (37) , remove set screws (42), now motor can be dismantled from the whole pump.

Loose set screws (40), the motor hub can now be disassembled with the motor shaft.

12. OPERATING DATA

The following working pressures (pressure in piping incl. the pressure increase caused by the pump) and number of revolutions are allowed in standard pumps.

Pump	Max. working pressure[bar] NIALBZ/STAINLESS STEEL	Max. working pressure[bar] GGG40	Max.RPM
TSL40-180	16	16	3600
TSL50-180	16	16	3600

Notice: Some pump combinations allow higher speeds than stated in the table – see actual pump name plate.

The above-mentioned max. working pressure is a design value – delivered pumps are pressure tested according to actual application requirements and actual flange standards.

For instance the above-mentioned max. working pressure is **NOT** valid for pumps approved

by a classification society. Pumps approved by classification societies have been pressure tested according to the requirements of these societies, i.e. a test pressure of 1.5 x the permissible working pressure. The test pressure is stated in the test certificate and stamped into the discharge flange of the pump.

13. EU DECLARATION OF CONFORMITY

DESMI Pumping Technology A/S, hereby declare that our pumps of the TSL type are manufactured in conformity with the following essential safety and health requirements in the COUNCIL DIRECTIVE 2006/42/EC on machines, Annex 1.

The following harmonized standards have been used:

EN/ISO 13857:2019	Safety of machinery. Safety distances to prevent danger zones being reached by the upper limbs
EN 809:1998 + A1:2009	Pumps and pump units for liquids – Common safety requirements
EN12162:2001+A1:2009	Liquid pumps – Safety requirements – Procedure for hydrostatic testing
EN 60204-1:2006/A1:2009	Safety of machinery – Electrical equipment of machines (item 4, General requirements)
Ecodesign Directive (2009/125/EC)	Water pumps: Commission Regulation No 547/2012. Applies only to water pumps marked with the minimum efficiency index MEI. See pump nameplate.

Pumps delivered by us connected with prime movers are CE-marked and comply with the above requirements.

Pumps delivered by us without prime movers (as partly completed machinery) must only be used when the prime mover and the connection between prime mover and pump comply with the above requirements.

Nørresundby, January 31 2023



Henrik Mørkholt Sørensen
Managing Director

DESMI Pumping Technology A/S
Tagholm 1
9400 Nørresundby

14. INFORMATION RELEVANT FOR DISASSEMBLY OR DISPOSAL AT END-OF-LIFE

No damage materials are used in DESMI pumps – please refer to DESMI Green Passport (can be sent on request – contact a DESMI sales office) – i.e. common recycling companies can handle the disposal at end-of-life. Alternatively the pump and motor can be returned to DESMI at end-of-life for safe recycling.

15. ASSEMBLY DRAWING TSL40/50-180/12

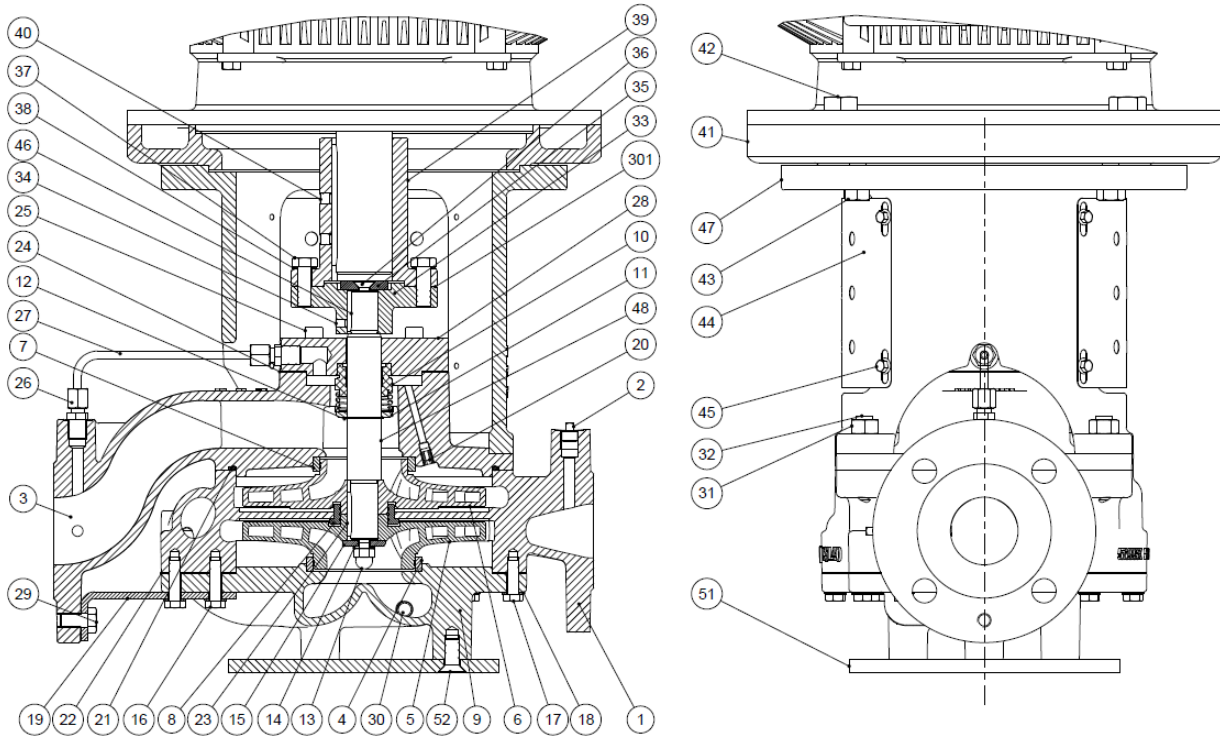

Note: Shim (301) is to ensure the axial position of motor coupling before mounting motor and it's removed after mounting motor.

1	Casing volute	27	Vent pipe
2	Plug	28	Seal cover
3	Inlet cover	29	Set screws
4	Bottom seal ring	30	Plug
5	Bottom impeller	31	Nut
6	Top impeller	32	Stud
7	Top seal ring	33	Pump hub
8	Mid seal ring	34	Point screw
9	Casing suction	35	Thrust plate
10	Shaft seal	36	Sunk Allen screw
11	Stop ring	37	Screw
12	Snap ring	38	Washer
13	Cap nut	39	Motor hub
14	Spring washer	40	Point screw
15	Washer	41	Inter flange
16	Set screw	42	Set screws
17	Set screws	43	Set screws
18	Washer	44	Guard
19	Support plate	45	INSEX-screw
20	Throttle	46	Key
21	O-ring	47	Motor bracket
22	Gasket	48	Pump shaft
23	Key	51	Base plate
24	Gasket	52	Sunk Allen screw
25	Allen screw	301	Shims
26	Hex. fitting		

16. DIMENSIONAL SKETCH

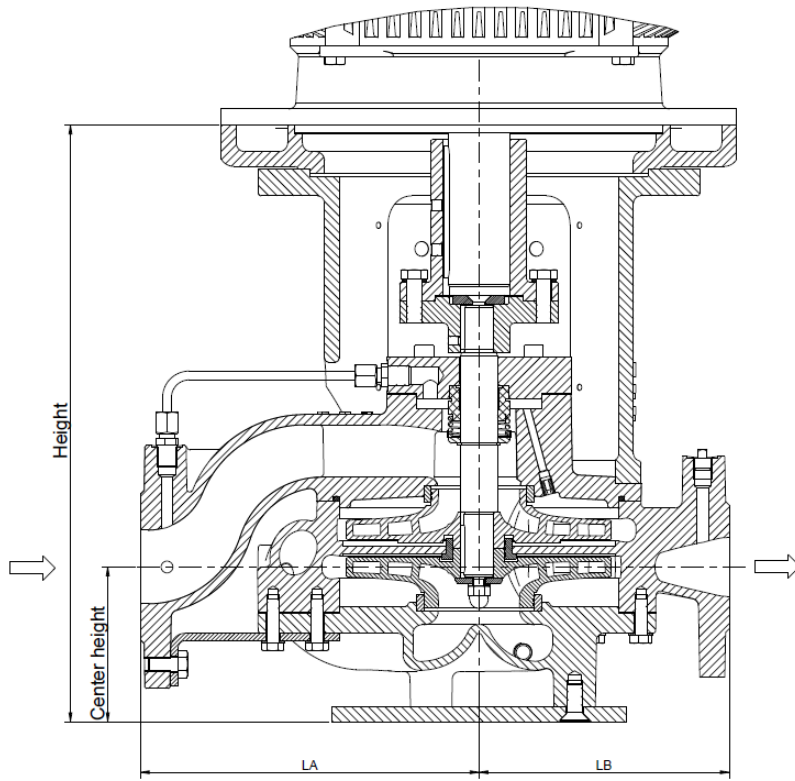

SUCTION

DELIVERY

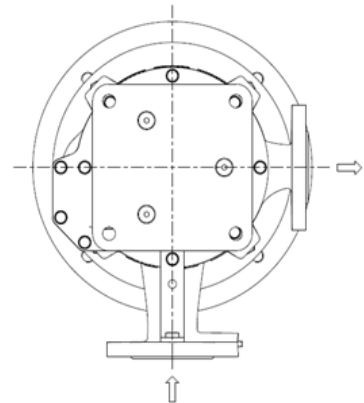
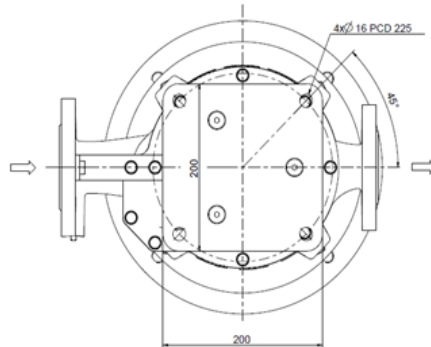
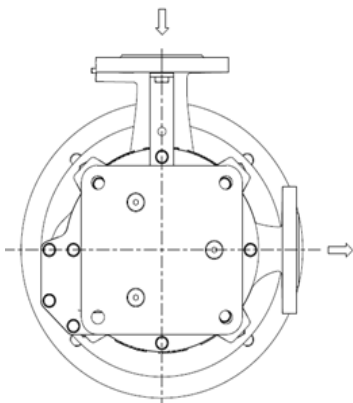
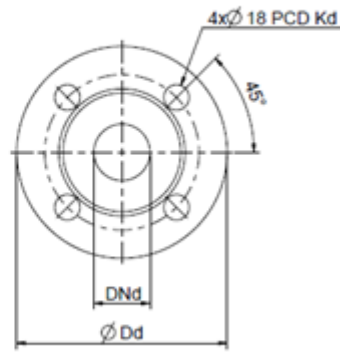
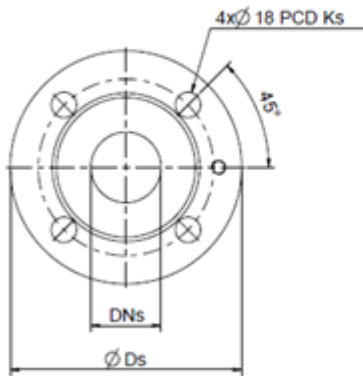

Connection holes on pump: Manometer: 1/4" BSP. Drain: 1/4" BSP.

TSL	Motor Size	LA	LB	Center Height	Height	DNs	Ds	Ks	DNd	Dd	Kd
TSL40-180	160	230	170	105	405	50	165	125	40	150	110
	132				375						
	100/112				354						
	90				354						
	80				354						
TSL50-180	160/180	260	180	110	425	65	185	145	50	165	125
	132				395						
	100/112				374						
	90				374						
	80				374						