

DESMI Vertical In-Line Centrifugal Pump

OPERATION AND MAINTENANCE INSTRUCTIONS

NSL MONOBLOC & SPACER



DESMI Pumping Technology A/S

Manual: T1542	Language: English	Revision: A.6(04/23)
------------------	----------------------	-------------------------

Special pump Number.

Contents

1. GENERAL DESCRIPTION	5
1.1. General	6
1.2. Personnel qualification and training	6
1.3. EU & UK declaration of conformity	7
1.4. ATEX declaration of conformity	8
1.4.1. Product description	8
1.4.2. Precautions	8
1.5. Information relevant for disassembly or disposal at end-of-life	9
2. SAFETY	10
2.1. Key to safety symbols/markings	10
2.1.1. Signal words	10
2.1.2. Hazard symbols	10
2.1.3. Labels on the product	11
2.2. Intended use	12
2.3. Consequences and risks caused by non-compliance with this manual	13
2.4. Safety awareness	13
2.5. Safety information for the operator/user	13
2.6. Safety information for maintenance, inspection and installation	14
2.7. Unauthorised modes of operation	14
2.8. Explosion protection	14
2.8.1. Marking	15
2.8.2. Temperature limits	15
2.8.3. Monitoring equipment	15
2.8.4. Operating limits	15
2.9. Frost protection	16
3. TRANSPORTATION, PREVENTATION AND TEMPORARY STORAGE	17
3.1. Checking the condition upon delivery	17
3.2. Transport	17
3.3. Storage/Preservation	19
3.4. Return to supplier	19
3.5. Disposal	20
4. TECHNICAL SPECIFICATION	21
4.1. Work range	21
4.2. Technical data	24
4.2.1. Maximum work pressure	24
4.2.2. Noise emission	25

4.2.3.	Generated vibration.....	26
4.2.4.	Hydraulic capacity	26
4.2.5.	Allowed maximum motor frame size	26
4.3.	Name plate	27
4.3.1.	Explanation of the type.....	27
4.3.2.	Explanation of the type number and pump number	29
4.3.3.	Explanation of pump performance	29
4.4.	Dimensional drawing	30
4.4.1.	NSL-215/265 -02 combination	30
4.4.2.	NSL-215/265 -12 combination	31
4.4.3.	NSL-215/265 -13/14 combinations	32
4.4.4.	NSL-330/415/418/465/525 -02 combination	33
4.4.5.	NSL-330/415/418/465/525 -12 combination	35
4.4.6.	NSL-330/415/418/465/525 -13/14 combinations	37
4.5.	Pump weight	39
5.	INSTALLATION.....	41
5.1.	Mounting / Fastening	41
5.2.	Wiring.....	41
6.	COMMISSIONING, START-UP AND SHUTDOWN	50
6.1.	Prerequisites for commissioning / start-up.....	50
6.2.	Priming and venting the pump.....	50
6.3.	Start up	52
6.3.1.	Start-up procedure	53
6.4.	Checking the shaft seal	54
6.5.	Shut down	54
6.6.	Operating limits	55
6.7.	Frequency of starts	56
6.8.	Fluid handled	56
6.8.1.	Flow rate	56
6.8.2.	Density of fluid handled.....	57
6.8.3.	Abrasive fluids	57
6.9.	Decommissioning / out of service	57
6.10.	Return to service	58
7.	TROUBLESHOOTING.....	59
7.1.	Mechanical seal failure analysis	60
8.	INSPECTION AND SERVICE PLAN	65
8.1.	Supervision of operation	65
8.2.	Inspection work	73

8.2.1. Cleaning filter	73
8.2.2. Drainage and cleaning	73
9. DISMANTLING THE PUMP SET	75
9.1. 02 and 12 combinations	78
9.1.1. Access to impeller.....	78
9.1.2. Dismantling shaft seal.....	83
9.1.3. Dismantling seat	87
9.1.4. Dismantling bearing (only 02 combination)	87
9.1.5. Inspection	88
9.1.6. Dismantling coupling (02 combination) / shaft (12 combination).....	88
9.2. 13 and 14 combinations	89
9.2.1. Access to impeller.....	89
9.2.2. Dismantling shaft seal.....	92
9.2.3. Dismantling seat	94
9.2.4. Dismantling shaft with bearings	94
9.2.5. Inspection	94
10. ASSEMBLING THE PUMP SET	95
10.1. Tightening Torques.....	95
10.2. 12 combination.....	96
10.2.1. Fitting sealing rings.....	96
10.2.2. Fitting shaft seal.....	97
10.2.3. Fitting impeller	98
10.2.4. Fitting rear cover or motor bracket	100
10.2.5. Shaft	101
10.3. 02, 13 and 14 combinations	102
10.3.1. Fitting sealing rings.....	102
10.3.2. Fitting bearings or shaft with bearings.....	103
10.3.3. Fitting water deflector	104
10.3.4. Fitting shaft seal.....	106
10.3.5. Fitting impeller	107
10.3.6. Fitting bearing housing and rear cover	108
10.3.7. Shaft	109
10.3.8. Fitting coupling.....	110
11. ORDERING SPARE PARTS	115
11.1. Assembly drawing NSL-215/265 -02 combination	117
11.2. Spare parts list NSL-215/265 -02 combination	118
11.3. Assembly drawing NSL-215/265 -12 combination	119
11.4. Spare parts list NSL-215/265 -12 combination	120
11.5. Assembly drawing NSL-215/265 -S12 combination.....	121
11.6. Spare parts list NSL-215/265 -S12 combination	122

11.7. Assembly drawing NSL-330/415/465 -02 combination	123
11.8. Spare parts list NSL-330/415/465 -02 combination	124
11.9. Assembly drawing NSL-330/415/465 -12 combination	125
11.10. Spare parts list NSL-330/415/465 -12 combination	126
11.11. Assembly drawing NSL300-418 -02 combination	127
11.12. Spare parts list NSL300-418 -02 combination	128
11.13. Assembly drawing NSL300-418 -12 combination	129
11.14. Spare parts list NSL300-418 -12 combination	130
11.15. Assembly drawing NSL200/250/300-525 -02 combination	131
11.16. Spare parts list NSL200/250/300-525 -02 combination	132
11.17. Assembly drawing NSL200/250/300-525 -12 combination	133
11.18. Spare parts list NSL200/250/300-525 -12 combination	134
11.19. Assembly drawing NSL350-525 -02 combination	135
11.20. Spare parts list NSL350-525 -02 combination	136
11.21. Assembly drawing NSL350-525 -12 combination	137
11.22. Spare parts list NSL350-525 -12 combination	138
11.23. Assembly drawing NSL-215/265 -14 combination	139
11.24. Spare parts list NSL-215/265 -14 combination	140
11.25. Assembly drawing NSL-330/415/465 -14 combination	141
11.26. Spare parts list NSL-330/415/465 -14 combination	142
11.27. Assembly drawing NSL300-418 -14 combination	143
11.28. Spare parts list NSL300-418 -14 combination	144
11.29. Assembly drawing NSL200/250/300-525 -14 combination	145
11.30. Spare parts list NSL200/250/300-525 -14 combination	146
11.31. Assembly drawing NSL350-525 -14 combination	147
11.32. Spare parts list NSL350-525 -14 combination	148
APPENDIX A	149
APPENDIX B	151

1. GENERAL DESCRIPTION

These operation and maintenance instructions apply to both DESMI NSL pumps in Monobloc and Spacer design. After the publish of this manual, the original manual will no longer apply to the products for subsequent shipments. But the original manual still applies to the past or in-use products. Desmi reserves the right to make any type of update, without prior notice and obligation to update previous manuals. The latest version of the manual is acquirable by scanning the QR code in the front page of this manual.

The pump is particularly suitable for the pumping of water in connection with cooling systems, cooling of diesel engines, as bilge pumps, ballast pumps, fire pumps, brine pumps, pumps for irrigation, fish farms, water works, district heating, salvage corps, army and navy, etc.

The pump is a single-stage vertical "in-line" centrifugal pump (i.e. horizontal inlet and outlet on the same line) equipped with stainless steel shaft, mechanical shaft seal, and closed impeller.

The pump shaft, with or without ball bearing mounted on it, is coupled with electric motor shaft either by rigid coupling or by flexible coupling.

The pump suction and discharge ports are casted flanges which comply with European Union flange standards as well as other compatible flange standards , e.g., ASME, ISO and JIS standards.

The pump has various options and combinations for the wet part material to fulfil desired applications. The options and combinations include cast iron, copper alloy and stainless steel in different grades.

The pump couples with electric motors that comply with IEC or NEMA standards. The pump can also be customized to couple with other kinds of engines, e.g. hydraulic motor, diesel engine, which is special engineering to order products and specific operation and maintenance instructions are applied.

The operation and maintenance instructions include descriptions for two product groups based on their different designs, $\varnothing 215/265$ and $\varnothing 330/415/418/525$. The numbers refer to the standard impeller diameter of the pump.

$\varnothing 215/265$: Pumps with $\varnothing 215$ or $\varnothing 265$ impellers:

The impeller is equipped with one sealing ring. The line through inlet and outlet is flush with the center line of the shaft.

$\varnothing 330/415/418/465/525$: Pumps with $\varnothing 330$, $\varnothing 415$, $\varnothing 418$, $\varnothing 465$ or $\varnothing 525$ impellers:

The impeller is equipped with two sealing rings. The line through inlet and outlet is offset in relation

to the center line of the shaft. Pumps delivered by us connected with prime movers are CE-marked and comply with the above requirements.

1.1. General

This manual contains general installation, operation and maintenance instructions that must be observed to ensure safe pump operation and prevent personal injury and damage to property.

The safety information in all sections of this manual must be complied with. This manual must be read and completely understood by the specialist personnel /operators responsible, prior to installation and commissioning.

The content of this manual must be available to the specialist personnel at the site at all times.

Information attached directly to the pump must always be complied with and be kept in a perfectly legible condition at all times. This applies to, for example:

- Arrow indicating the direction of rotation
- Marking for connections
- Name plate

The operator is responsible for ensuring compliance with all local regulations not taken into account in this manual.

1.2. Personnel qualification and training

All personnel involved must be fully qualified to transport, install, operate, maintain and inspect the machinery this manual refers to. The responsibilities, competence and supervision of all personnel involved in transport, installation, operation, maintenance and inspection must be clearly defined by the operator.

Deficits in knowledge must be rectified by means of training and instruction provided by sufficiently trained specialist personnel. If required, the operator can commission the manufacturer / supplier to train the personnel. Training on the pump (set) must always be supervised by technical specialist personnel.

1.3. EU & UK declaration of conformity

DESMI PUMPING TECHNOLOGY A/S, hereby declare that our pumps of NSL Monobloc & Spacer type are manufactured in conformity with the following essential safety and health requirements in the COUNCIL DIRECTIVE 2006/42/EC on machines, Annex 1.

The following harmonized standards have been used:

EN/ISO 13857:2019	Safety of machinery. Safety distances to prevent danger zones being reached by the upper limbs
EN 809:1998 + A1:2009	Pumps and pump units for liquids – Common safety requirements
EN12162:2001+A1:2009	Liquid pumps – Safety requirements – Procedure for hydrostatic testing
EN 60204-1:2018	Safety of machinery – Electrical equipment of machines (item 4, General requirements)
Ecodesign Directive (2009/125/EC).	Water pumps: Commission Regulation No 547/2012. Applies only to water pumps marked with the minimum efficiency index MEI. See pump nameplate
Directive 2014/34/EU	Equipment and protective systems intended for use in potentially explosive atmospheres. Applies only to water pumps marked with Ex. See pump nameplate

Pumps delivered by us connected with prime movers are CE-marked and comply with the above requirements.

Pumps delivered by us without prime movers (as partly completed machinery) must only be used when the prime mover and the connection between prime mover and pump comply with the above requirements.

Nørresundby, April. 23 2023



Henrik Mørkholt Sørensen

Managing Director

DESMI Pumping Technology A/S

Tagholm 1, 9400 Nørresundby

1.4. ATEX declaration of conformity

1.4.1. Product description

The precautions to be taken using the pumps in areas where the ATEX rules for “Ex II 2G Ex h IIb T4 Gb X” marked equipment apply. Only pumps mounted with EX-marked nameplate from DESMI are approved for / allowed to be used in EX areas.

The pumps have been examined according to EN80079-36:2016 and EN80079-37:2016. Constructional safety “c” and an Ignition Hazard Assessment has been made. As a result of this assessment the following precautions are to be taken.

1.4.2. Precautions



NOTE: Dry run is not allowed. Fill pump with liquid before start up. A $\cos \varphi$ measuring device can be fitted to the power circuit and set to trip the drive power in case of the power consumption being too low. The liquid in the pump also serves as coolant for the shaft seal. Dry run will result in frictional heat being developed causing critical high temperatures at seal faces.



NOTE: Pumping against closed outlet valve is not allowed for more than 2 minutes. A pressure switch can be fitted to trip the drive power in case of the outlet pressure being too high.



NOTE: Choking or clogging of the pump can result in either too low load or overload of the motor or bending of the shaft. Use a strainer / filter in the suction pipe. A $\cos \varphi$ measuring device can be fitted to the power circuit and set to trip the drive power in case of power consumption being too low or too high. The thermistors (if any) in the electric motor can only be used to trip the drive power at overload.



NOTE: User must replenish grease according to instruction manuals and replace bearings after 90% of rated life i.e. 22500 hours. The bearing housing is fitted with a temperature sensor (or two in Spacer pumps) to be connected to the electrical control system on site. Set the system to trip the drive power 10°C above normal operating temperature.



NOTE: Max. allowed liquid temperature is 80°C for fresh water and most likely less for other liquids. The pump housing can be fitted with a temperature sensor to be connected to the electrical control system on site and then set this to trip the drive power 10°C above normal operating temperature. Contact DESMI in case of doubt about max. allowed liquid temperature.

Nørresundby, April. 23 2023

Henrik Mørkholt Sørensen

Managing Director

DESMI Pumping Technology A/S

Tagholm 1, 9400 Nørresundby

1.5. Information relevant for disassembly or disposal at end-of-life

No harmful materials are used in DESMI pumps – please refer to DESMI Green Passport (can be sent on request – contact a DESMI sales office) – i.e. common recycling companies can handle the disposal at end-of-life. Alternatively the pump and motor can be returned to DESMI at end-of-life for safe recycling.



2. SAFETY

All the information contained in this section refers to hazardous situations.

2.1. Key to safety symbols/markings

2.1.1. Signal words

The following signal words and symbols are used to identify safety messages in these instructions:

 DANGER	<p>DANGER indicates a hazard with a high level of risk which, if not avoided, will result in death or serious injury.</p>
 WARNING	<p>WARNING indicates a hazard with a medium level of risk which, if not avoided, could result in death or serious injury.</p>
CAUTION	<p>CAUTION indicates a hazard with a low level of risk which, if not avoided, could result in damage to the product or system.</p>



Information with this heading is used to address practices not related to personal injury.

2.1.2. Hazard symbols



General hazard

In conjunction with one of the signal words, this symbol indicates a hazard which will or could result in death or serious injury.



Electrical hazard

In conjunction with one of the signal words, this symbol indicates a hazard involving electrical voltage and identifies information about protection against electrical voltage.



Explosion protection

This symbol identifies information about avoiding explosions in potentially explosive atmospheres in accordance with EC Directive 2014/34/EU (ATEX).



Machine damage

In conjunction with the signal word CAUTION, this symbol indicates a hazard for the machine and its functions.

2.1.3. Labels on the product

The diagrams below indicate the location of the machine's safety and information labels.

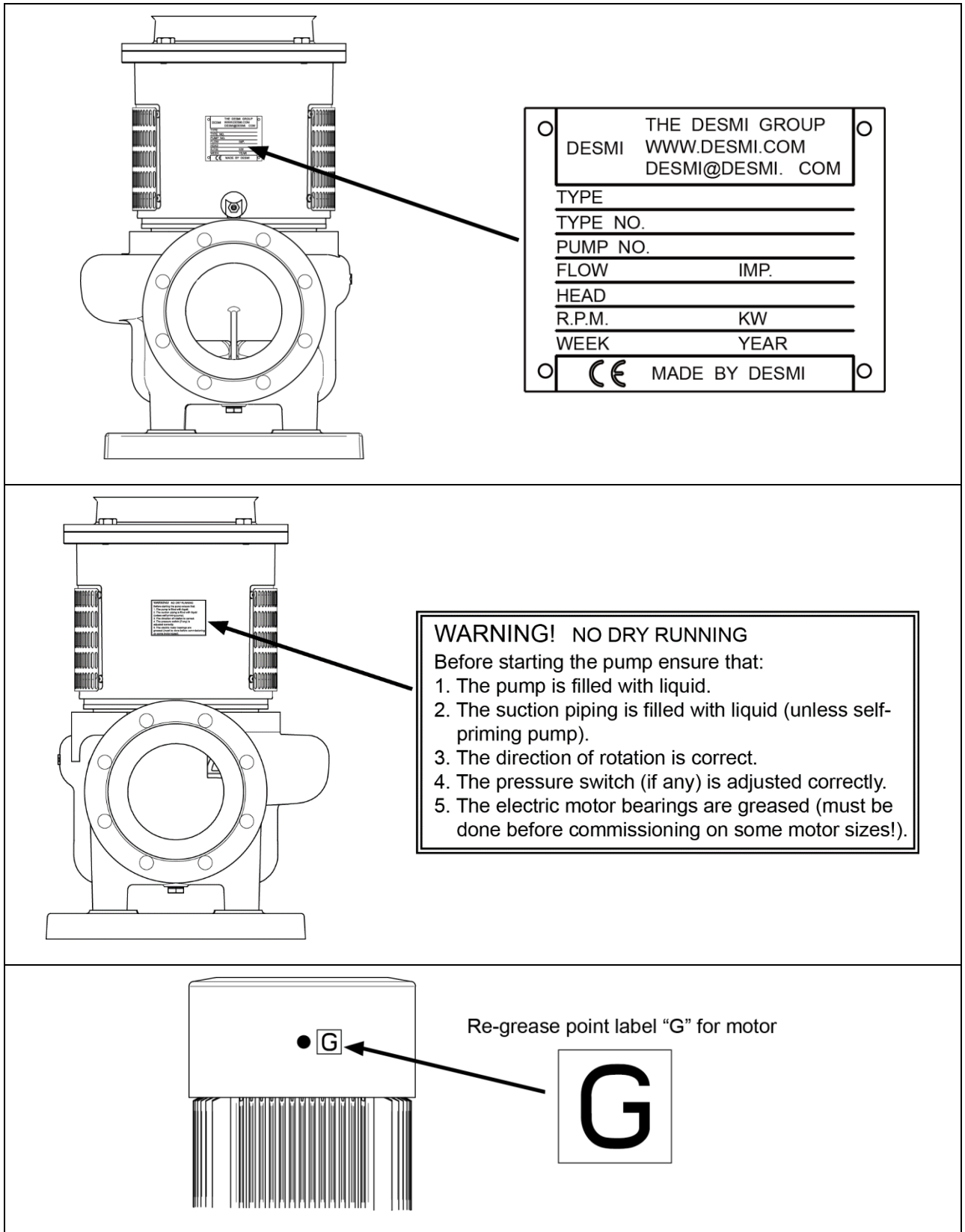

2.2. Intended use

- The pump (set) must only be operated within the operating limits described in the other applicable documents.
- Only operate pumps / pump sets which are in perfect technical condition.
- Do not operate the pump (set) in partially assembled condition.
- Only use the pump to handle the fluids described in the order or product literature of the pump model or variant.
- Never operate the pump without the fluid to be handled.
- Observe the information on minimum flow rates specified in the product literature (to prevent overheating, bearing damage, etc.).
- Observe the information on maximum flow rates specified in the product literature (to prevent overheating, mechanical seal damage, cavitation damage, bearing damage, etc.).
- Do not throttle the flow rate on the suction side of the pump (to prevent cavitation damage).
- Consult the manufacturer about any other modes of operation not described in the product literature.

Prevention of foreseeable misuse

- Never open the discharge-side shut-off elements further than permitted.
 - The maximum flow rate specified in the technical product literature would be exceeded.
 - Risk of cavitation damage
- Never exceed the permissible operating limits (pressure, temperature, etc.) specified in the product literature.
- Observe all safety information and instructions in this manual.

2.3. Consequences and risks caused by non-compliance with this manual

- Non-compliance with this manual will lead to forfeiture of warranty cover and of any and all rights to claims for damages.
- Non-compliance can, for example, have the following consequences:
 - Hazards to persons due to electrical, thermal, mechanical and chemical effects and explosions
 - Failure of important product functions
 - Failure of prescribed maintenance and servicing practices
 - Hazard to the environment due to leakage of hazardous substances.

2.4. Safety awareness

In addition to the safety information contained in this manual and the intended use, the following safety regulations shall be complied with:

- Accident prevention, health and safety regulations
- Explosion protection regulations
- Safety regulations for handling hazardous substances
- Applicable standards, directives and laws

2.5. Safety information for the operator/user

- The operator shall fit contact guards for hot, cold and moving parts and check that the guards function properly.
- Do not remove any contact guards during operation.
- Provide the personnel with protective equipment and make sure it is used.
- Contain leakages (e.g. at the shaft seal) of hazardous fluids handled (e.g. explosive, toxic, hot) so as to avoid any danger to persons and the environment. Adhere to all relevant laws.
- Eliminate all electrical hazards. (In this respect, refer to applicable national safety regulations and/or regulations issued by the local energy supply companies.)
- If shutting down the pump does not increase potential risk, fit an emergency stop control device in the immediate vicinity of the pump (set) during pump set installation.

2.6. Safety information for maintenance, inspection and installation

- Modifications or alterations of the pump are only permitted with the manufacturer's prior consent.
- Use only original spare parts or parts authorised by the manufacturer. The use of other parts can invalidate any liability of the manufacturer for resulting damage.
- The operator ensures that maintenance, inspection and installation is performed by authorised, qualified specialist personnel who are thoroughly familiar with the manual.
- Only carry out work on the pump (set) during standstill of the pump.
- The pump casing must be cooled down to ambient temperature.
- Pump pressure must be released and the pump must have been drained.
- When taking the pump set out of service, always adhere to the procedure described in the manual.
- Decontaminate pumps which handle fluids posing a health hazard.
- As soon as the work is completed, re-install and/or re-activate any safety relevant and protective devices. Before returning the product to service, observe all instructions on commissioning.

2.7. Unauthorised modes of operation

Never operate the pump (set) outside the limits stated in the order documentation and in this manual. The warranty relating to the operating reliability and safety of the supplied pump (set) is only valid if the equipment is used in accordance with its intended use.

2.8. Explosion protection

Always observe the information on explosion protection given in this section when operating the product in potentially explosive atmospheres. Only pumps/pump sets marked as explosion-proof and identified as such in the data sheet may be used in potentially explosive atmospheres.

Special conditions apply to the operation of explosion-proof pump sets to EU Directive 2014/34/EU (ATEX). Especially adhere to the sections in this manual marked with the Ex symbol and the following sections.

The explosion-proof status of the pump set is only assured if the pump set is used in accordance with its intended use. Never operate the pump set outside the limits stated in the data sheet and on the name plate. Prevent impermissible modes of operation at all times.

2.8.1. Marking

The marking on the pump refers to the pump part only. DESMI's standard EX marking for NSL pumps is: Ex II 2G Ex h IIb T4 Gb X.

The motor has its own marking. The marking is maintained on the condition that the temperatures the pump causes to develop at the motor flange and motor shaft are permitted by the motor manufacturer. The motors used DESMI on pumps with ATEX certification meet this condition.

2.8.2. Temperature limits

In normal pump operation, the highest temperatures are to be expected on the surface of the pump casing and at the shaft seal. The surface temperature at the pump casing corresponds to the temperature of the fluid handled. If the pump is heated in addition, the operator of the system is responsible for observing the specified temperature class and fluid temperature (operating temperature). The max. allowed liquid temperature is 80°C for fresh water and most likely less for other liquids.

If the pump is to be operated at a higher temperature or if the pump is part of a pool of pumps, contact DESMI for the maximum permissible operating temperature.

If a pump is supplied without motor (as part of a pool of pumps), the motor specified in the order documentation of the pump must meet the following conditions:

- The permissible temperature limits at the motor flange and motor shaft must be higher than the temperatures generated by the pump.
- Contact DESMI for the actual pump temperatures.

2.8.3. Monitoring equipment

The pump (set) must only be operated within the limits specified in the order documentation and on the name plate. If the system operator cannot warrant compliance with these operating limits, appropriate monitoring devices must be used. Check whether monitoring equipment is required to ensure that the pump set functions properly.

Contact DESMI for further information on monitoring equipment.

2.8.4. Operating limits

Refer to the [chapter 1.4](#) – i.e. if there's a risk of too high liquid temperatures, then a PT100 sensor should be mounted in the pump casing. As standard the max. allowed liquid temperature is 80°C for ATEX marked NSL pumps.

2.9. Frost protection

Pumps which are not in operation during frost periods are to be drained to avoid frost damage. Remove the plug (3) at the bottom to empty the pump. Alternatively, it is possible to use anti-freeze liquids in normal pump configurations.

3. TRANSPORTATION, PREVENTATION AND TEMPORARY STORAGE

3.1. Checking the condition upon delivery

1. On transfer of goods, check each packaging unit for damage.
2. In the event of in-transit damage, assess the exact damage, document it and notify DESMI or the supplying dealer (as applicable) and the insurer about the damage in writing immediately.

3.2. Transport

DANGER



FALLING OBJECT HAZARD!

The pump (set) could slip out of the suspension arrangement, which will cause death or serious injury

Always transport the pump (set) in the specified position.

Do not attach the suspension arrangement to the free shaft end or the motor eyebolt.

Monitor the weight data and the centre of gravity.

Obey the applicable local health and safety regulations.

Use suitable, permitted lifting accessories, for example, self-tightening lifting tongs.

CAUTION



RISK OF DAMAGING TO THE SHAFT SEAL!

Transport the pump incorrectly could cause damage to the shaft seal!

To transport the pump / pump set from the lifting, tackle as shown below.

Before shipment, fasten the pump securely on pallets or the like.

The weights of the pumps are given in [chapter 4.5](#). The weight of the motor is given in motor operation manual. It can be found in

- Shipping documents together with the cargo
- Shipping mark on cargo box
- Other documents for the shipment, contracts or orders, etc.

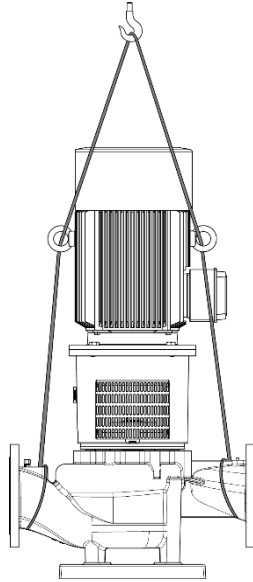

Figure 3-1: Transport



NOTE: The lifting straps must not bear against sharp edges and corners.

3.3. Storage/Preservation

If commissioning is to take place some time after delivery, we recommend that the following measures be taken for pump (set) storage.

CAUTION



RISK OF PROPERTY DAMAGE!

Incorrect storage condition could cause damage to the pump (set)!

Make sure that the storage space is in correct humidity.

Make sure that the storage location is clean and without vermin.

For outdoor storage, cover the packed or unpacked pump (set) and accessories with waterproof material.

CAUTION



RISK OF PROPERTY DAMAGE!

Wet, contaminated or damaged openings and connections could cause leakage or damage to the pump!

When you put the pump into storage, clean and cover the pump openings and connections as needed.

Store the pump (set) in a dry, protected room where the atmospheric humidity is as constant as possible. Rotate the shaft by hand once a month. For storing a pump (set) that was operated, the shutdown measures must be adhered to.

See also: DESMI Pump Storage and Preservation at:

www.desmi.com/media/vqkqgh54/t1534uk.pdf

3.4. Return to supplier

1. Drain the pump as per operating instructions.
2. Always flush and clean the pump, particularly if it was used for handling noxious, explosive, hot or other hazardous fluids.
3. If the pump set handled fluids whose residues could lead to corrosion damage in the presence of atmospheric humidity or could ignite upon contact with oxygen, the pump set must also be neutralised, and anhydrous inert gas must be blown through the pump to ensure drying.
4. Always complete and enclose a certificate of decontamination when returning the pump (set). Always indicate any safety and decontamination measures taken.

3.5. Disposal

WARNING

ENVIRONMENTAL AND HEALTH HAZARD!

The pump might contain fluids that could cause harm to the environment and your health.

Obey all legal regulations on the disposal of fluids posing a health hazard.

Collect and properly dispose of flushing fluid and any residues of the fluid handled.

Handle the chemicals and machine components according to instructions and local regulations.

Wear safety clothing and a protective mask. Obey the instructional material.



1. Dismantle the pump (set).
Collect greases and other lubricants during dismantling.
2. Separate and sort the pump materials, e.g. by:
 - Metals
 - Plastics
 - Rubber
 - Electronic waste
 - Greases and other lubricants
3. Dispose of materials in accordance with local regulations or in another controlled manner.

4. TECHNICAL SPECIFICATION

4.1. Work range

The working range depends on the basic hydraulic design, the type of connection and sealings. The module in the pumps with the strictest specification determines the allowable pressure and temperature of the medium in the pumps. Pumps with ATEX (explosion safety) marking, which are applied in explosive hazardous atmospheres, have an additional restriction of the medium temperature. The general working specifications can be summarized as follows:

Media temperature range for:

Lower limit temperature: - 20°C (minus 40°C for brine pumps in ductile iron with spec. seal)

Upper limit temperature: +80°C for fresh water (up to 150°C with special shaft seal),
+40°C for sea water (up to +60°C seawater in Super Duplex pumps
with special shaft seal)

(The pump is suitable for pumping of clean fresh water with temperatures up to 100 °C when ball bearing mounted on pump shaft, and up to 140 °C when without ball bearing mounted on pump shaft. For pumping of clean fresh water with temperatures above 100 °C, DESMI only delivers ductile iron (for instance GGG40) or martensitic stainless steel (for instance 1.4436) for pump casing and rear cover.)

Ambient temperature range for:

Lower limit temperature: - 20 °C

Upper limit temperature: + 45 °C

(1. Avoid freezing the pump.

2. If the ambient temperature exceeds the above value or the motor is located more than 1000 m above sea level, the motor cooling is less effective and could require an adapted motor power. Please contact your supplier for more detailed advice.)

Media density and viscosity

Density: Max. 2500 kg/m³

Viscosity: Max. 500 cSt.

(Pumping liquids with a higher density and/or viscosity than water requires more mechanical torque from pump shaft and more power from the electric motor. This could cause overloading of the pump shaft and motor. Contact your supplier for advice, if needed.)

Imposed vibration:

During DESMI factory testing the accumulated vibration on pump shall be less than 2.8mm/s. Adding any external excited vibrations on site the pump vibrations to be less than 7 mm/s otherwise anti-vibration foundation or other vibration reduction measure on pump to be applied. Refer to DESMI Installation Guidelines at:

http://www.desmi.com/media/sd5ltlox/guidelines_uk.pdf

Minimum inlet pressure

$NPSH_{req} + \text{Suction pipework friction} + \text{Fluid vapour pressure} - \text{Fluid surface pressure} + 0.5m$

(It is the pressure that will not lead pump cavitation in specific pump operational conditions and specific pumping media. NPSH_{req.} is given in the contract technical documentation.)

Maximum inlet pressure

$\text{Pump maximum working pressure} - \text{pump shut head}$

(It is the pressure that shall not lead pump outlet pressure to excess pump allowed maximum working pressure in specific pump operational conditions and specific pumping media. Pump maximum working pressure and shut head is given in the technical documentation.)

Minimum number of revolution

The minimum number of revolutions depends on the minimum revolution number of the coupled motor. Refer to motor operation manual or contact motor supplier for the minimum revolution number of the motor, if needed.

Maximum number of revolution

The following number of revolutions are allowed in standard pumps.

Pump	Max. RPM	Pump	Max. RPM	Pump	Max. RPM
NSL80-215	3600	NSL125-415	1800	NSL250-330	1800
NSL80-265	3600	NSL150-215	1800	NSL250-415	1800
NSL80-330	3600	NSL150-265	1800	NSL250-525	1800
NSL100-215	3600	NSL150-330	1800	NSL300-415	1800
NSL100-265	3600	NSL150-415	1800	NSL300-418	1800
NSL100-330	3000	NSL200-265	1800	NSL300-465	2000
NSL100-415	1800	NSL200-330	1800	NSL300-525	1800

Pump	Max. RPM	Pump	Max. RPM	Pump	Max. RPM
NSL125-215	3600	NSL200-415	1800	NSL350-525	1600
NSL125-265	3600	NSL200-525	1800		
NSL125-330	1800	NSL250-265	1800		

Notice: Some pumps allow higher speeds than stated in the table, see actual pump name plate.

(The real operation number of revolution is given in the contract technical documentation, which also might be less than the number in the table, because in specific applications, pumping liquids with a higher density and/or viscosity than water require more torque from pump shaft and more mechanical power from the electric motor. This could cause overloading of the pump shaft and the motor. Contact your supplier for advice, if needed.)

The permissible loads on the flanges

The permissible loads on the flanges are indicated in the following table. The values apply to standard pumps in bronze (Rg5) and cast iron (GG20). As for pumps in SG iron (GGG40), NiAlBz or stainless steel, the values are to be increased by factor 1.5.

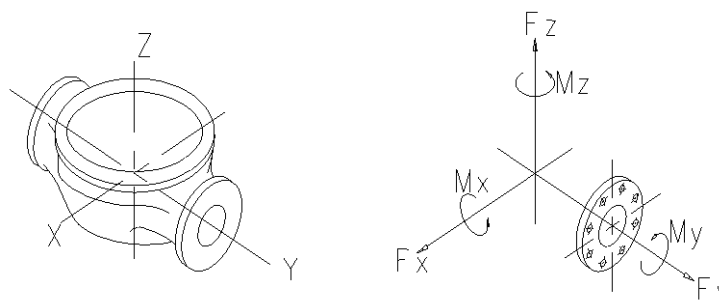

Figure 4-1: The permissible loads on the flanges

Pump	Fy N	Fz N	Fx N	ΣF	My Nm	Mz Nm	Mx Nm	Σ Mt
NSL80-215 NSL80-265 NSL80-330	800	950	850	1500	550	350	400	750
NSL100-215 NSL100-265 NSL100-330 NSL100-415	1000	1250	1150	2000	650	400	500	900
NSL125-215 NSL125-265 NSL125-330 NSL125-415	1250	1600	1430	2500	830	520	650	1160
NSL150-215 NSL150-265 NSL150-330 NSL150-415	1500	1900	1700	2950	1000	650	800	1400

Pump	Fy N	Fz N	Fx N	ΣF	My Nm	Mz Nm	Mx Nm	ΣMt
NSL200-265 NSL200-330 NSL200-415 NSL200-525	2000	2520	2260	3920	1330	860	1060	1860
NSL250-265 NSL250-330 NSL250-415 NSL250-525	2500	3150	2820	4900	1770	1140	1400	2470
NSL300-415 NSL300-418 NSL300-465 NSL300-525	3000	3750	3350	5860	2750	1900	2200	4000
NSL350-525	3500	4370	3920	6840	3630	2500	2930	5300

In connection with the permissible loads on the flanges, the following is to be observed

$$\left(\frac{\sum F_{calc}}{\sum F}\right)^2 + \left(\frac{\sum M_{calc}}{\sum M_t}\right)^2 < 2$$

Where index “calc” is the valves calculated by the user.

At the same time, none of the forces or moments may exceed the indicated figure multiplied by 1.4.

4.2. Technical data

4.2.1. Maximum work pressure

The following working pressures (pressure in piping incl. the pressure rise caused by the pump) are allowed in standard pumps.

Pump	Pressure [bar] Rg5/ CC491K	Pressure [bar] GG20/ EN-GJL-200	Pressure [bar] GGG40/ EN-GJS-400-15	Pump	Pressure [bar] Rg5/ CC491K	Pressure [bar] GG20/ EN-GJL-200	Pressure [bar] GGG40/ EN-GJS-400-15
NSL80-215	16	16	25	NSL150-415	9	13	25
NSL80-265	14,5	14,5	25	NSL200-265	9	9	25
NSL80-330	15	15	25	NSL200-330	7	13	25
NSL100-215	13	13	25	NSL200-415	9	13	25
NSL100-265	14,5	14,5	25	NSL200-525	14	14	25
NSL100-330	8	14	25	NSL250-265	10	10	25
NSL100-415	10	12,5	25	NSL250-330	7	12	25

Pump	Pressure [bar] Rg5/CC491K	Pressure [bar] GG20/EN-GJL-200	Pressure [bar] GGG40/EN-GJS-400-15	Pump	Pressure [bar] Rg5/CC491K	Pressure [bar] GG20/EN-GJL-200	Pressure [bar] GGG40/EN-GJS-400-15
NSL125-215	10	10	25	NSL250-415	9	12	25
NSL125-265	14,5	14,5	25	NSL250-525	14	14	25
NSL125-330	7	12	25	NSL300-415	9	12	25
NSL125-415	9	13	25	NSL300-418	6	16	25
NSL150-215	8	8	25	NSL300-465	9	14	25
NSL150-265	7	7	25	NSL300-525	14	14	25
NSL150-330	7	13	25	NSL350-525	10	16	25

The max. working pressure for NiAlBz/CC333G and stainless-steel (Refer 1.4410&1.4436) pumps is 1.5 times max. working pressure for bronze (RG5/CC491K).

The above-mentioned max. working pressure is a design value – delivered pumps are pressure tested according to actual application requirements or actual flange standards.

For instance, the above-mentioned max. working pressure is **NOT** valid for pumps approved by a classification society. Pumps approved by classification societies are pressure tested according to the requirements of these societies, i.e. a test pressure of 1.5 x the permissible working pressure. The test pressure is stated in the test certificate and stamped into the discharge flange of the pump.

4.2.2. Noise emission

The noise level indicated is the airborne noise including the motor. The noise level depends on the motor type supplied, as the noise from the pump can be calculated as the noise level of the motor + 2dB(A). The noise level is for pumps with electric motors.

The motor noise in rated work condition is given in motor operation manual.

4.2.3. Generated vibration

The pump vibration at rated work condition is less than 2.8 mm/s which are measured on designated position.

The vibration can change when work condition changes, e.g. rotation speed, duty point shift by external force, liquid type, etc.

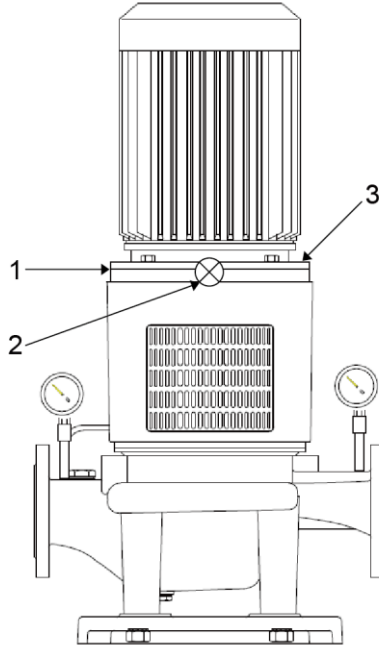

Figure 4-2: Vibration measuring position

4.2.4. Hydraulic capacity

The capacity of flow and head of the pump is stated on the name plate on the pump. If the pump is delivered without motor, the pump capacity is to be indicated on the plate when mounting the motor.

4.2.5. Allowed maximum motor frame size

Pump size	Pump Structure	Motor range
ø215	02 combination	≤225
ø215	12 combination	≤180
ø215	13 or 14 combination	≤250
ø215	15 combination	≤280
ø265	02 combination	≤280
ø265	12 combination	≤200

Pump size	Pump Structure	Motor range
ø265	13 or 14 combination	≤280
ø265	15 combination	≤315
ø330	02, 12, 13 or 14 combination	≤315
ø415/418	02, 12, 13 or 14 combination	≤355
ø465	02, 12 or 14 combination	≤400
ø525	02, 12 or 14 combination	≤450

4.3. Name plate

All the NSL pumps are provided with a name plate on body to describe pump hydraulic and mechanical specification.

(Individual motor name plate on motor body, of which description is given in motor operation manual.)

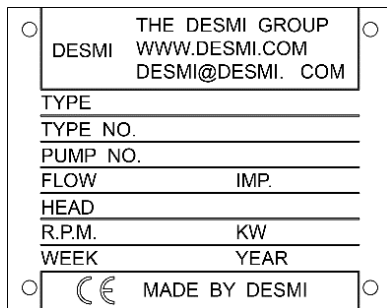

Figure 4-3: Name plate with CE mark

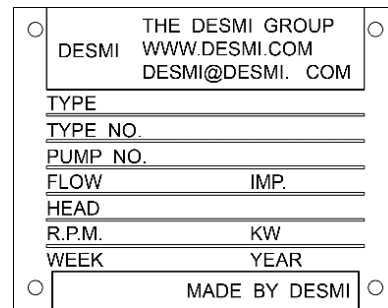

Figure 4-4: Name plate without CE mark

4.3.1. Explanation of the type

The pumps are manufactured in various size, materials and configurations which are started in the type description on the name plate. See below.

NSLXXX-YYY-MR-Z

XXX: Pressure branch diameter

YYY: Norminal impeller diameter

M: The material combination of the pump.

R: The assembly combination of the pump.

Z: Other variants

M may be the following:

A:	Casing and rear cover: Cast iron + cast iron alloy. Impeller and sealing rings: NiAlBz/CC333G
B:	Casing and rear cover: Cast iron + cast iron alloy. Impeller and sealing rings: Stainless.
C:	All cast iron
D:	Casing and rear cover: Bronze Rg5/CC491K or NiAlBz/CC333G. Impeller and sealing rings: NiAlBz or Stainless steel
E:	Casing and rear cover: NiAlBz /CC333G and bronze alloy. Impeller and sealing rings: NiAlBz/CC333G
S:	Casing, rear cover, impeller and sealing rings: 1.4410 or stainless steel alloy.
U:	Nonmagnetic material

The pumps can be delivered in other material combinations according to agreement with the supplier.

R may be the following:

02:	Monobloc, with bearing in the pump
12:	Monobloc, without bearing in the pump
13:	Spacer, light bearing housing
14:	Spacer, heavy bearing housing
15:	Spacer, heavy bearing housing and heavy motor bracket (special motor bracket)

Z may be the following:

i:	PN16 flanges
j:	PN25 flanges
k:	Special flange
l:	Other shaft seal
m:	BS flanges
n:	ANSI flanges
o:	Shockproof design
p:	Other design
q:	JIS flanges

Any use of the pump is to be evaluated on the basis of the materials used in the pump. In case of doubt, contact the supplier.

Pumps in material combinations A, B and C are primarily used for fresh water. Pumps in material combination D, S are primarily used for seawater.

If the pumps are designed for special purposes, the following is to be indicated:

1. Pump No.
2. Pump type

3. Application
4. Comment

4.3.2. Explanation of the type number and pump number

The type number is a number to describe the main feature configuration of the pumps.

The pump number is a serial number to identify individual pump contract and manufacture information for service and spare parts ordering. The pump number can also be found on technical documentation.

4.3.3. Explanation of pump performance

M3/HOUR & TOTAL HEAD M is rated flow and corresponding total head, which is achievable by the pump by verification, or by test on mutual agreement. If test is performed, ISO9906 Grade 2B is applied as DESMI standard, or other test standard on mutual agreement.

IMP is impeller's real diameter after trimming to obtain rated flow and total head. IMP is a necessary pump specification in spare parts ordering.

RPM is pump rotation speed given from motor to obtain the rated flow and total head. The real pump rotation speed can have minor shift due to real load on the motors.

KW is the required nominal motor power output, which is greater than pump power consumption to avoid motor overloading.

WEEK and **YEAR** is manufacturing completion date.

4.4. Dimensional drawing

All the flanges in the manual are drilled according to EN1092 PN10. Some products may differ from PN10 in dimension ØD. Customized drilling solutions are available upon request.

4.4.1. NSL-215/265 -02 combination

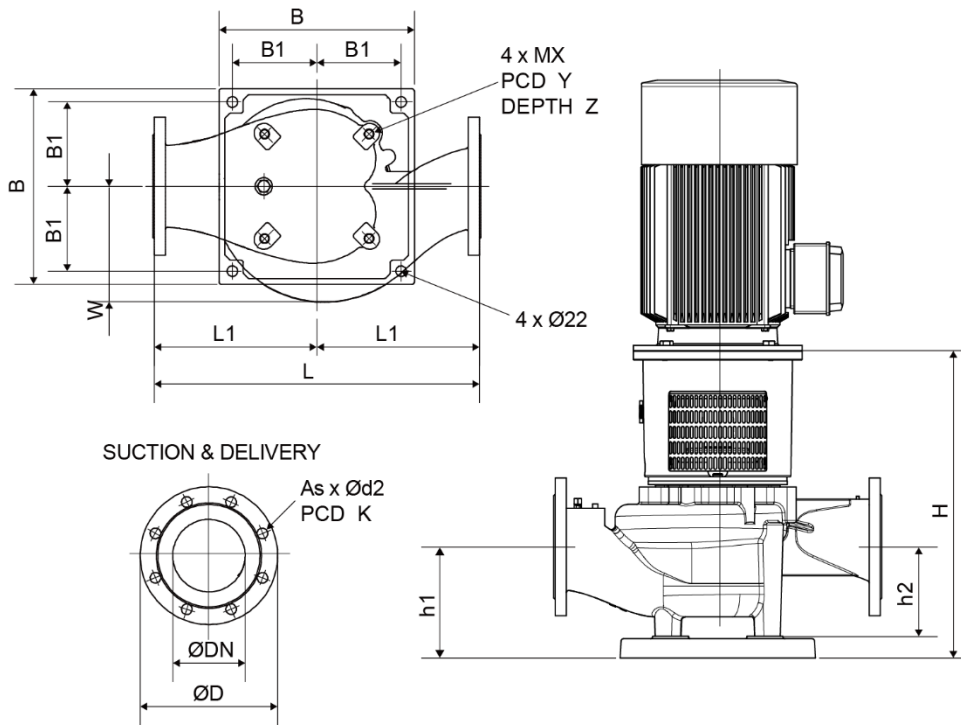

Figure 4-5: Ø215/265-02 combination

Manometer: 1/4" BSP. Drain: 3/8" BSP. Priming: 1/2" BSP

Type	H	h1	h2	L	L1	W	DN	D	d2	K	X	Y	Z	B	B1	As
NSL80-215	567	200	155	530	265	163	80	200	18	160	20	306	25	405	175	8
NSL80-265	574	200	155	580	290	193	80	200	18	160	20	306	25	405	175	8
NSL100-215	587	200	155	580	290	181	100	220	18	180	20	306	25	405	175	8
NSL100-265	593	200	155	630	315	193	100	220	18	180	20	306	25	405	175	8
NSL125-215	600	200	155	630	315	203	125	250	18	210	20	306	25	405	175	8
NSL125-265	617	200	155	680	340	227	125	250	18	210	20	306	25	405	175	8
NSL150-215	636	230	185	680	340	239	150	285	22	240	20	306	25	405	175	8
NSL150-265	640	200	155	730	365	250	150	285	22	240	20	306	25	405	175	8
NSL200-265	681	260	215	780	390	290	200	340	23	295	20	306	25	405	175	8

Type	H	h1	h2	L	L1	W	DN	D	d2	K	X	Y	Z	B	B1	As
NSL250-265	727	260	215	800	400	324	250	405	22	350	20	306	25	405	175	12

4.4.2. NSL-215/265 -12 combination

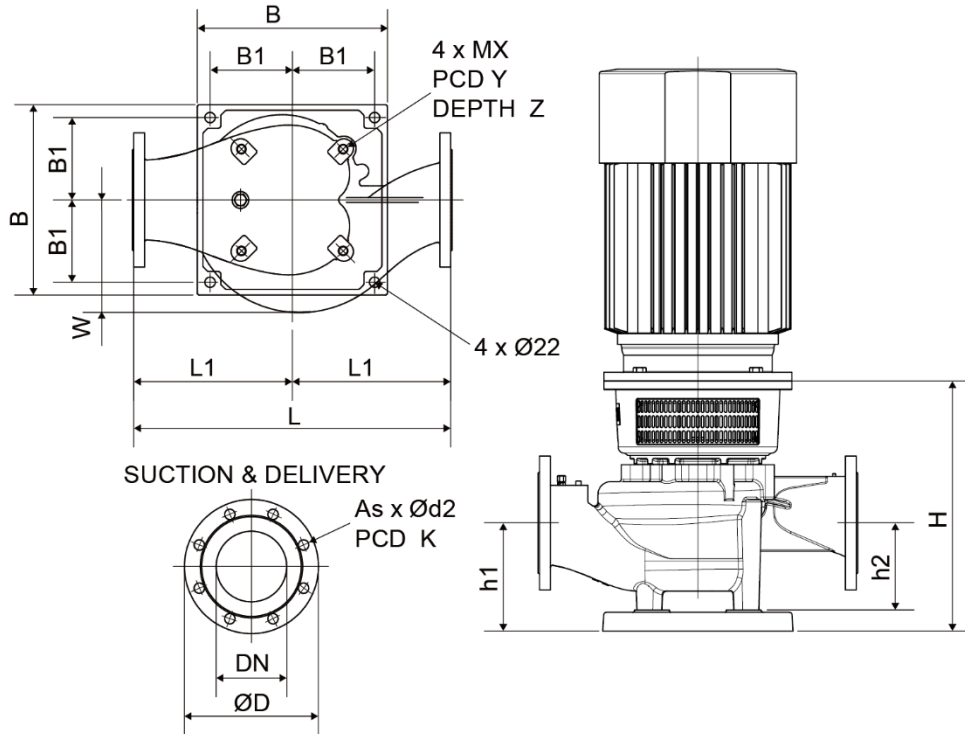

Figure 4-6: Ø215/265-12 combination

Manometer: 1/4" BSP. Drain: 3/8" BSP. Priming: 1/2" BSP

Type	H	h1	h2	L	L1	W	DN	D	d2	K	X	Y	Z	B	B1	As
NSL80-215	444	200	155	530	265	163	80	200	18	160	20	306	25	405	175	8
NSL80-265	450	200	155	580	290	193	80	200	18	160	20	306	25	405	175	8
NSL100-215	465	200	155	580	290	181	100	220	18	180	20	306	25	405	175	8
NSL100-265	470	200	155	630	315	193	100	220	18	180	20	306	25	405	175	8
NSL125-215	478	200	155	630	315	203	125	250	18	210	20	306	25	405	175	8
NSL125-265	493	200	155	680	340	227	125	250	18	210	20	306	25	405	175	8
NSL150-215	533	230	185	680	340	239	150	285	22	240	20	306	25	405	175	8
NSL150-265	517	200	155	730	365	250	150	285	22	240	20	306	25	405	175	8
NSL200-265	517	260	215	780	390	290	200	340	23	295	20	306	25	405	175	8
NSL250-265	604	260	215	800	400	324	250	405	22	350	20	306	25	405	175	12

4.4.3. NSL-215/265 -13/14 combinations

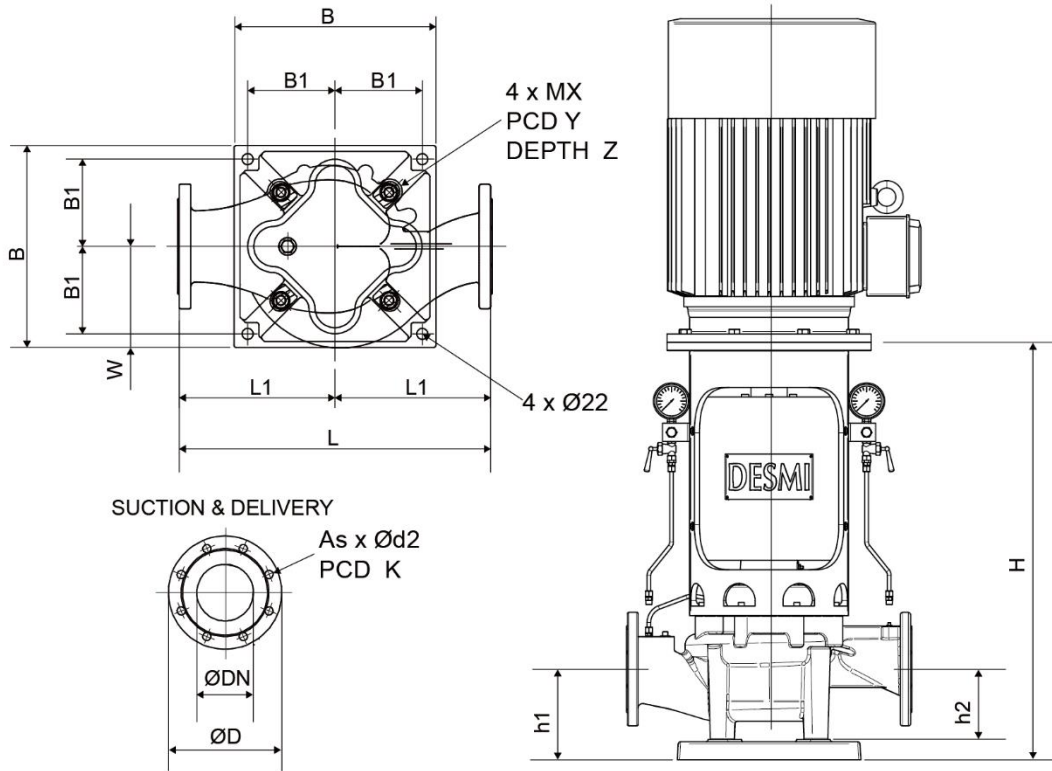

Figure 4-7: Ø215/265-13/14 combinations

Manometer:1/4"BSP. Drain:3/8"BSP. Priming:1/2"BSP

Type	H	h1	h2	L	L1	W	DN	D	d2	K	X	Y	Z	B	B1	As
NSL80-215	868	200	155	530	265	163	80	200	18	160	20	306	25	405	175	8
NSL80-265	900	200	155	580	290	193	80	200	18	160	20	306	25	405	175	8
NSL100-215	889	200	155	580	290	181	100	220	18	180	20	306	25	405	175	8
NSL100-265	920	200	155	630	315	193	100	220	18	180	20	306	25	405	175	8
NSL125-215	902	200	155	630	315	203	125	250	18	210	20	306	25	405	175	8
NSL125-265	943	200	155	680	340	227	125	250	18	210	20	306	25	405	175	8
NSL150-215	938	230	185	680	340	239	150	285	22	240	20	306	25	405	175	8
NSL150-265	967	200	155	730	365	250	150	285	22	240	20	306	25	405	175	8
NSL200-265	1008	260	215	780	390	290	200	340	23	295	20	306	25	405	175	8
NSL250-265	1035	260	215	800	400	324	250	405	22	350	20	306	25	405	175	12

4.4.4. NSL-330/415/418/465/525 -02 combination

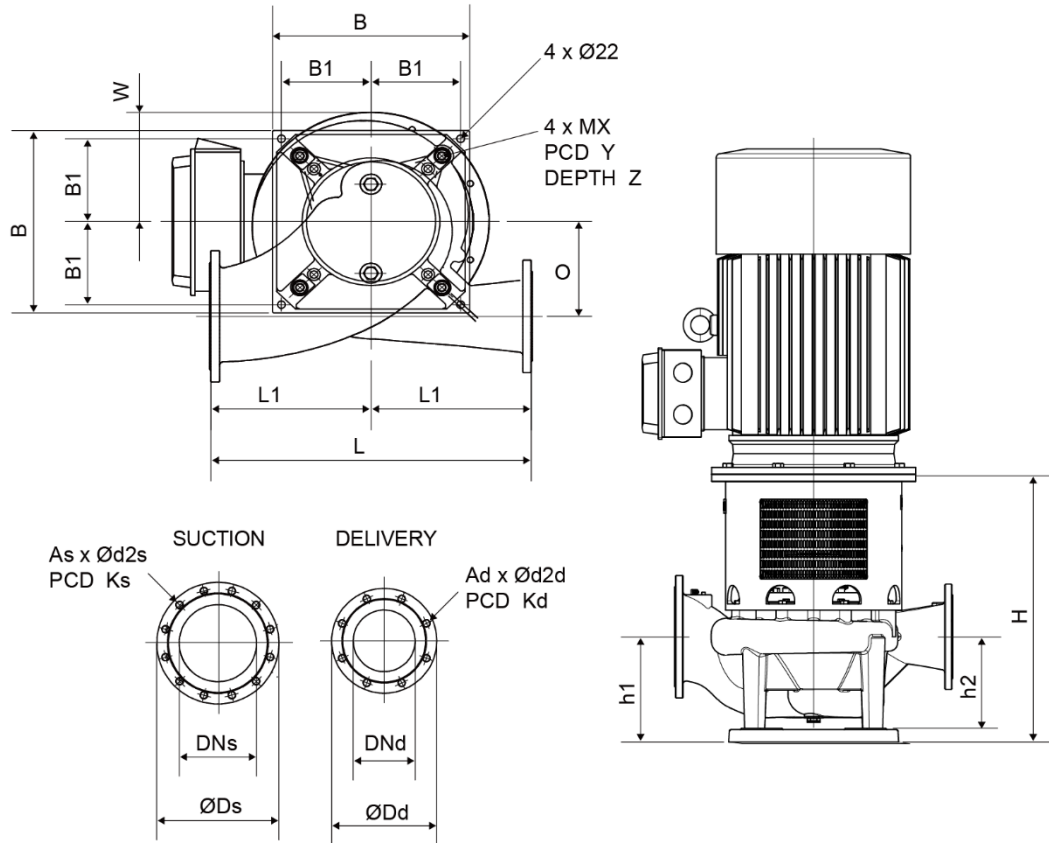

Figure 4-8: Ø330/415/418/465/525-02 combination

Manometer: 1/4" BSP. Drain: 3/4" BSP. Priming: 1/2" BSP

Base plate holes: Ø33 instead of Ø22 for NSL350-525

Type	H	h1	h2	L	L1	W	Ds A-exe.	Dd A-exe.	Ds D-exe.	Dd D-exe.	DN _s	DN _d	ks	kd
NSL80-330	738	260	215	600	300	250	235	200	220	200	100	80	180	160
NSL100-330	743	260	215	650	325	250	270	235	250	220	125	100	210	180
NSL100-415	761	260	215	700	350	275	270	235	250	220	125	100	210	180
NSL125-330	788	300	255	700	350	250	300	270	285	250	150	125	240	210
NSL125-415	799	300	255	750	375	278	300	270	285	250	150	125	240	210
NSL150-330	799	300	255	750	350	275	360	300	340	285	200	150	295	240
NSL150-415	845	340	295	800	400	293	360	300	340	285	200	150	295	240
NSL200-330	842	340	295	900	450	301	425	360	395	340	250	200	350	295
NSL200-415	860	340	295	900	450	308	425	360	395	340	250	200	350	295
NSL200-525	1050	380	335	900	450	385	425	360	425	360	250	200	350	295

Type	H	h1	h2	L	L1	W	Ds A-exe.	Dd A-exe.	Ds D-exe.	Dd D-exe.	DNs	DNd	ks	kd
NSL250-330	889	380	335	1000	500	327	485	425	445	395	300	250	400	350
NSL250-415	902	380	335	1000	500	355	485	425	445	395	300	250	400	350
NSL250-525	1060	390	345	1100	550	390	485	425	445	395	300	250	400	350
NSL300-415	953	420	375	1200	600	377	555	485	505	445	350	300	460	400
NSL300-418	978	410	365	1300	650	427	505	445	505	445	350	300	460	400
NSL300-465	1106	410	365	1200	600	370	505	445	505	445	350	300	460	400
NSL300-525	1105	435	390	1200	600	419	555	485	555	485	350	300	460	400
NSL350-525	1195	430	390	1400	700	453	565	505	580	520	400	350	515	460

Type	d2s	d2d	As	Ad	X	Y	Z	B	B1	O
NSL80-330	18	18	8	8	20	306	25	405	175	200
NSL100-330	18	18	8	8	20	306	25	405	175	210
NSL100-415	18	18	8	8	20	450	25	550	250	250
NSL125-330	22	18	8	8	20	306	25	405	175	225
NSL125-415	22	18	8	8	20	450	25	550	250	260
NSL150-330	22	22	8	8	20	450	25	550	250	235
NSL150-415	22	22	8	8	20	450	25	550	250	275
NSL200-330	22	22	12	8	20	450	25	550	250	260
NSL200-415	22	22	12	8	24	560	28	550	250	285
NSL200-525	22	22	12	8	24	560	28	550	250	330
NSL250-330	22	22	12	12	24	560	28	550	250	275
NSL250-415	22	22	12	12	24	560	28	550	250	305
NSL250-525	22	22	12	12	24	560	28	550	250	340
NSL300-415	22	22	16	12	24	560	28	550	250	320
NSL300-418	22	22	16	12	24	560	28	550	250	360
NSL300-465	22	22	16	12	24	560	28	550	250	330
NSL300-525	22	22	16	12	24	560	28	550	250	365
NSL350-525	26	22	16	16	24	750	36	900	410	380

4.4.5. NSL-330/415/418/465/525 -12 combination

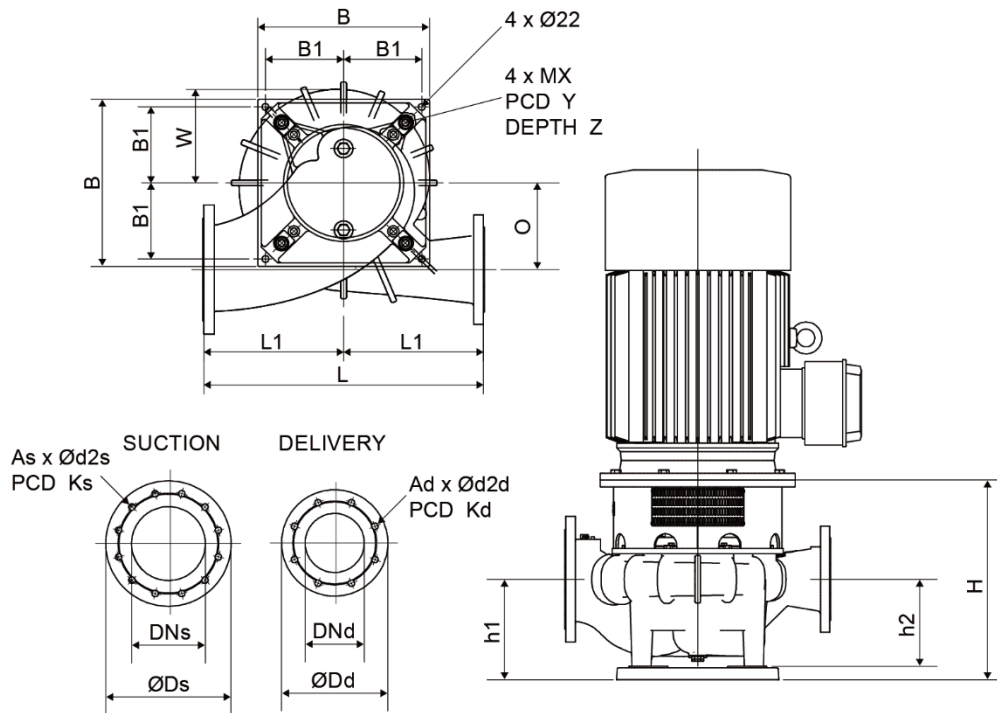

Figure 4-9: Ø330/415/418/465/525-12 combination

Manometer:1/4"BSP. Drain:3/4"BSP. Priming:1/2"BSP

Base plate holes: Ø33 instead of Ø22 for NSL350-525

Type	H	h1	h2	L	L1	W	Ds A-exe.	Dd A-exe.	Ds D-exe.	Dd D-exe.	DNs	DNd	ks	kd
NSL80-330	499	260	215	600	300	250	235	200	220	200	100	80	180	160
NSL100-330	504	260	215	650	325	250	270	235	250	220	125	100	210	180
NSL100-415	547	260	215	700	350	275	270	235	250	220	125	100	210	180
NSL125-330	549	300	255	700	350	250	300	270	285	250	150	125	240	210
NSL125-415	585	300	255	750	375	278	300	270	285	250	150	125	240	210
NSL150-330	599	300	255	750	350	259	360	300	340	285	200	150	295	240
NSL150-415	631	340	295	800	400	293	360	300	340	285	200	150	295	240
NSL200-330	643	340	295	900	450	280	425	360	395	340	250	200	350	295
NSL200-415	676	340	295	900	450	308	425	360	395	340	250	200	350	295
NSL200-525	805	380	335	900	450	385	425	360	425	360	250	200	350	295
NSL250-330	690	380	335	1000	500	303	485	425	445	395	300	250	400	350
NSL250-415	718	380	335	1000	500	330	485	425	445	395	300	250	400	350

Type	H	h1	h2	L	L1	W	Ds A-exe.	Dd A-exe.	Ds D-exe.	Dd D-exe.	DNs	DNd	ks	kd
NSL250-525	815	390	345	1100	550	390	485	425	445	395	300	250	400	350
NSL300-415	764	420	375	1200	600	344	555	485	505	445	350	300	460	400
NSL300-418	834	410	365	1300	650	427	505	445	505	445	350	300	460	400
NSL300-465	865	410	365	1200	600	370	505	445	505	445	350	300	460	400
NSL300-525	860	435	390	1200	600	419	555	485	505	445	350	300	460	400
NSL350-525	950	430	390	1400	700	453	565	505	580	520	400	350	515	460

Type	d2s	d2d	As	Ad	X	Y	Z	B	B1	O
NSL80-330	18	18	8	8	20	306	25	405	175	200
NSL100-330	18	18	8	8	20	306	25	405	175	210
NSL100-415	18	18	8	8	20	450	25	550	250	250
NSL125-330	22	18	8	8	20	306	25	405	175	225
NSL125-415	22	18	8	8	20	450	25	550	250	260
NSL150-330	22	22	8	8	20	450	25	550	250	235
NSL150-415	22	22	8	8	20	450	25	550	250	275
NSL200-330	22	22	12	8	20	450	25	550	250	260
NSL200-415	22	22	12	8	24	560	28	550	250	285
NSL200-525	22	22	12	8	24	560	28	550	250	330
NSL250-330	22	22	12	12	24	560	28	550	250	275
NSL250-415	22	22	12	12	24	560	28	550	250	305
NSL250-525	22	22	12	12	24	560	28	550	250	340
NSL300-415	22	22	16	12	24	560	28	550	250	320
NSL300-418	22	22	16	12	24	560	28	550	250	360
NSL300-465	22	22	16	12	24	560	28	550	250	330
NSL300-525	22	22	16	12	24	560	28	550	250	365
NSL350-525	26	22	16	16	24	750	36	900	410	380

4.4.6. NSL-330/415/418/465/525 -13/14 combinations

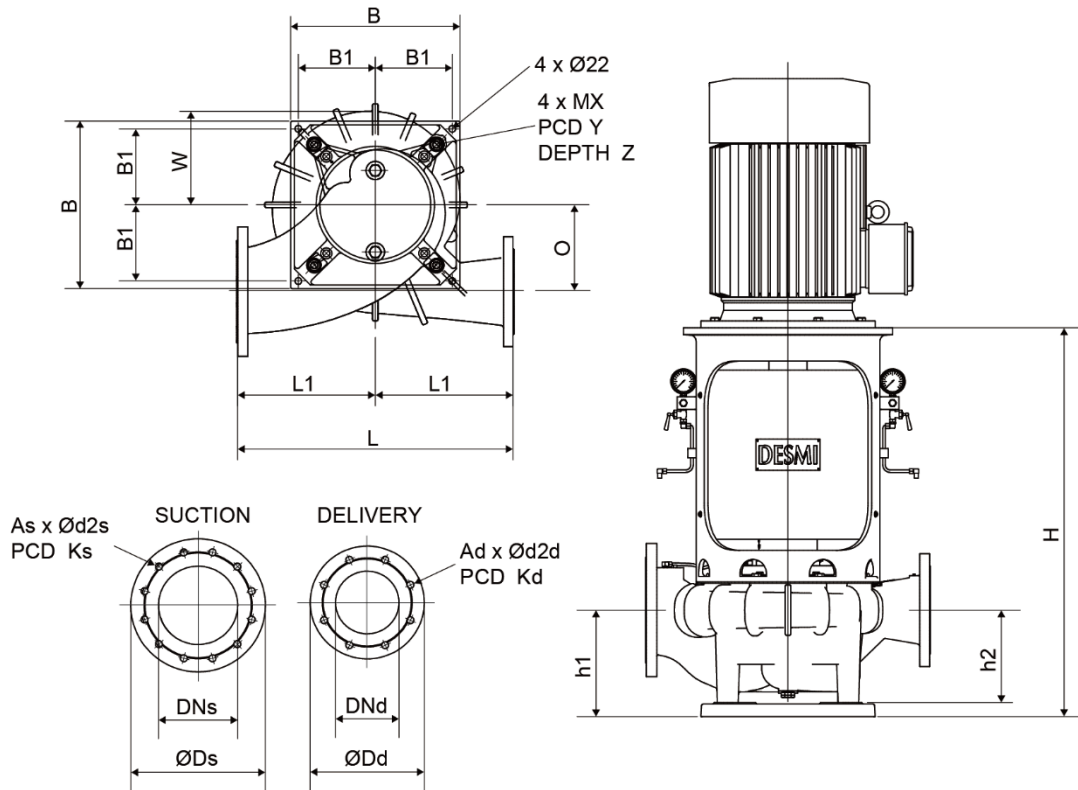

Figure 4-10: Ø330/415/418/465/525-13/14 combinations

Manometer:1/4"BSP. Drain:3/4"BSP. Priming:1/2"BSP

Base plate holes:Ø33 instead of Ø22 for NSL350-525.

Type	H	h1	h2	L	L1	W	Ds A-exe.	Dd A-exe.	Ds D-exe.	Dd D-exe.	DNs	DNd	ks	kd
NSL80-330	1079	260	215	600	300	250	235	200	220	200	100	80	180	160
NSL100-330	1084	260	215	650	325	250	270	235	250	220	125	100	210	180
NSL100-415	1107	260	215	700	350	275	270	235	250	220	125	100	210	180
NSL125-330	1130	300	255	700	350	250	300	270	285	250	150	125	240	210
NSL125-415	1145	300	255	750	375	278	300	270	285	250	150	125	240	210
NSL150-330	1140	300	255	750	350	275	360	300	340	285	200	150	295	240
NSL150-415	1191	340	295	800	400	293	360	300	340	285	200	150	295	240
NSL200-330	1183	340	295	900	450	301	425	360	395	340	250	200	350	295
NSL200-415	1241	340	295	900	450	308	425	360	395	340	250	200	350	295
NSL200-525	1515	380	335	900	450	395	425	360	425	360	250	200	350	295
NSL250-330	1230	380	335	1000	500	327	485	425	445	395	300	250	400	350
NSL250-415	1283	380	335	1000	500	355	485	425	445	395	300	250	400	350

Type	H	h1	h2	L	L1	W	Ds A-exe.	Dd A-exe.	Ds D-exe.	Dd D-exe.	DNs	DNd	ks	kd
NSL250-525	1525	390	345	1100	550	390	485	425	445	395	300	250	400	350
NSL300-415	1329	420	375	1200	600	377	555	485	505	445	350	300	460	400
NSL300-418	1359	410	365	1300	650	427	505	445	505	445	350	300	460	400
NSL300-465	1570	410	365	1200	600	370	505	445	505	445	350	300	460	400
NSL300-525	1570	435	390	1200	600	419	555	485	555	485	350	300	460	400
NSL350-525	1660	430	390	1400	700	453	565	505	580	520	400	350	515	460

Type	d2s	d2d	As	Ad	X	Y	Z	B	B1	O
NSL80-330	18	18	8	8	20	306	25	405	175	200
NSL100-330	18	18	8	8	20	306	25	405	175	210
NSL100-415	18	18	8	8	20	450	25	550	250	250
NSL125-330	22	18	8	8	20	306	25	405	175	225
NSL125-415	22	18	8	8	20	450	25	550	250	260
NSL150-330	22	22	8	8	20	450	25	550	250	235
NSL150-415	22	22	8	8	20	450	25	550	250	275
NSL200-330	22	22	12	8	20	450	25	550	250	260
NSL200-415	22	22	12	8	24	560	28	550	250	285
NSL200-525	22	22	12	8	24	560	28	550	250	330
NSL250-330	22	22	12	12	24	560	28	550	250	275
NSL250-415	22	22	12	12	24	560	28	550	250	305
NSL250-525	22	22	12	12	24	560	28	550	250	340
NSL300-415	22	22	16	12	24	560	28	550	250	320
NSL300-418	22	22	16	12	24	560	28	550	250	360
NSL300-465	22	22	16	12	24	560	28	550	250	330
NSL300-525	22	22	16	12	24	560	28	550	250	365
NSL350-525	26	22	16	16	24	750	36	900	410	380

4.5. Pump weight

The weights of the pumps in cast iron (A-GG20/EN-GJL-200&GGG40/EN-GJS-400-15) and bronze (D-Rg5/CC491K) combination (without motor, include base plate) are stated in the following table, The D-12 combination is only available in ø330/415/418/525. Pump in NiAlBz/CC333G and stainless steel (without motor) are equivalent to pumps in A code.

NSL /-02/12 combinations

Pump	A02/A12/D02/ D12 comb.[KG]	Pump	A02/A12/D02/D12 comb.[KG]
NSL80-215	126/141/100/----	NSL150-415	454/474/404/424
NSL80-265	135/152/109/----	NSL200-265	207/240/181/----
NSL80-330	256/261/206/211	NSL200-330	409/394/359/344
NSL100-215	137/154/111/----	NSL200-415	529/549/479/499
NSL100-265	136/153/120/----	NSL200-525	699/789/629/719
NSL100-330	261/267/211/217	NSL250-265	301/341/296/----
NSL100-415	379/399/329/349	NSL250-330	489/479/439/429
NSL125-215	148/163/122/----	NSL250-415	609/614/559/564
NSL125-265	154/175/128/----	NSL250-525	809/924/739/854
NSL125-330	276/282/226/232	NSL300-415	729/729/679/679
NSL125-415	414/434/364/384	NSL300-418	927/735/807/685
NSL150-215	167/191/141/----	NSL300-465	1145/1065/825/745
NSL150-265	172/197/146/----	NSL300-525	870/1005/800/935
NSL150-330	339/329/289/279	NSL350-525	1408/1285/1270/1230

NSL /-13/14 combinations

Pump	A13/14/D13/14 comb. [KG]	Pump	A13/14/D13/14 comb. [KG]
NSL80-215	186/186/201/201	NSL150-415	----/479/----/499
NSL80-265	195/195/212/212	NSL200-265	----/267/----/300
NSL80-330	301/ 301/306/306	NSL200-330	----/459/----/444
NSL100-215	197/197/214/214	NSL200-415	----/579/----/599
NSL100-265	196/196/213/213	NSL200-525	----/829/----/919
NSL100-330	311/311/317/317	NSL250-265	----/346/----/386
NSL100-415	404/404/424/424	NSL250-330	----/539/----/529
NSL125-215	208/208/223/223	NSL250-415	----/659/----/664
NSL125-265	214/214/235/235	NSL250-525	----/939/----/1054
NSL125-330	326/326/332/332	NSL300-415	----/759/----/759
NSL125-415	439/439/459/459	NSL300-418	----/1022/----/895
NSL150-215	----/227/ ----/251	NSL300-465	----/1370/----/1050
NSL150-265	232/232/257/257	NSL300-525	----/1000/----/1135
NSL150-330	----/389 /----/379	NSL350-525	----/1608/----/1570

5. INSTALLATION

5.1. Mounting / Fastening

DANGER



TEMPERATURE HAZARD!

When you install the pump that is used for pumping hot or very cold liquids, touching the pump surface might cause serious injury.

Always wear approved personal protective equipment.

The pump shall be mounted and fastened on a solid foundation with a flat and horizontal surface to avoid distortion. In case gaps bigger than 0.3 mm appear between any NSL pump base plate corner and foundation then insert shim(s) (at least 50x50 mm) between pump base plate corner and foundation before tightening the four bolts in the pump base plate corners.

The max. permissible loads on the flanges stated in [chapter 4.1](#) are to be observed.

5.2. Wiring

WARNING



SPECIAL SKILLS REQUIRED!

Incorrect wiring could cause death or serious injury.

Wiring work requires professional knowledge. Only authorised skilled person can do the work.

Always obey the valid rules and regulations.

For final design and installation of pumps supplied by DESMI, use DS information DS/CEN/TR 13930 (recommendations for installing pipe systems) and 13932 (recommendations for installing pumps) as guidelines.

Key elements of pump installation:

- Foundation
- Pipe system
- Pipe support
- Ventilation for installation

- Service areas and lifting points for motor and pump
- Pipe medium flow
- Optimum operating range
- Electrical connections (cables and screw assemblies)
- Electrical interference
- Using Common Mode filter for minimizing bearing currents when installing frequency convert

Pipe system before pump – suction line

DS13930/13932 recommends length of suction pipe "X" before the pump is around 3 to 5 x pipe diameter. For a DN100 pump, this will be equivalent to X=300 to 500mm. This rule of thumb ensures laminar flow before and after the pump that will give optimum operating conditions. But in practice, there are many installations where this is not obtained.

X= minimum length of suction pipe before flow-changing components.

Flow-changing components:

- Compensators
- Valves
- Filters
- Bends
- Orifice plate
- Etc.

Ensure a solid base plate to minimise vibrations and extend service intervals.

Avoid 90-degree bends, T-pieces or other components that can impede flow on the pump suction side.

Avoid radius of curvature of less than 1.5 times the nominal pipe diameter.

Avoid abrupt changes of cross-section along the piping system.

Gentle curves or Y-pieces to ensure optimum flow before (and after) the pump are best.

Use shims between pump base plate and foundation to avoid tension in the pump foot when the installation is secured.

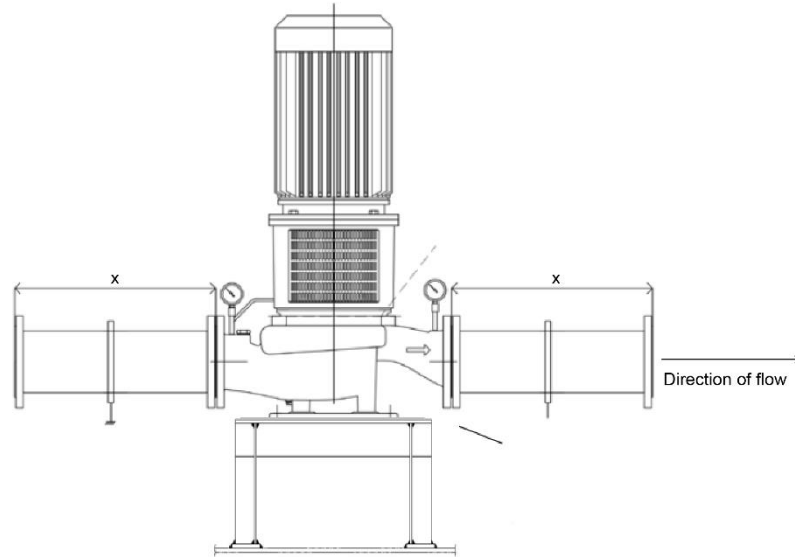

Figure 5-1: Marine & Offshore Installation

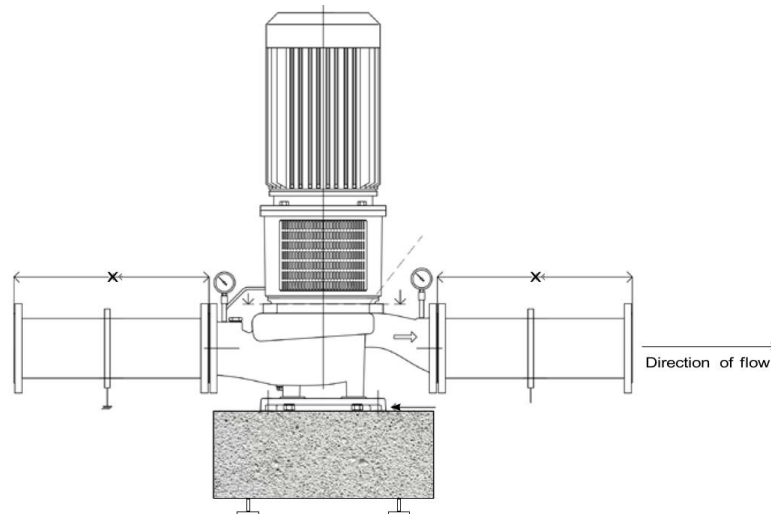
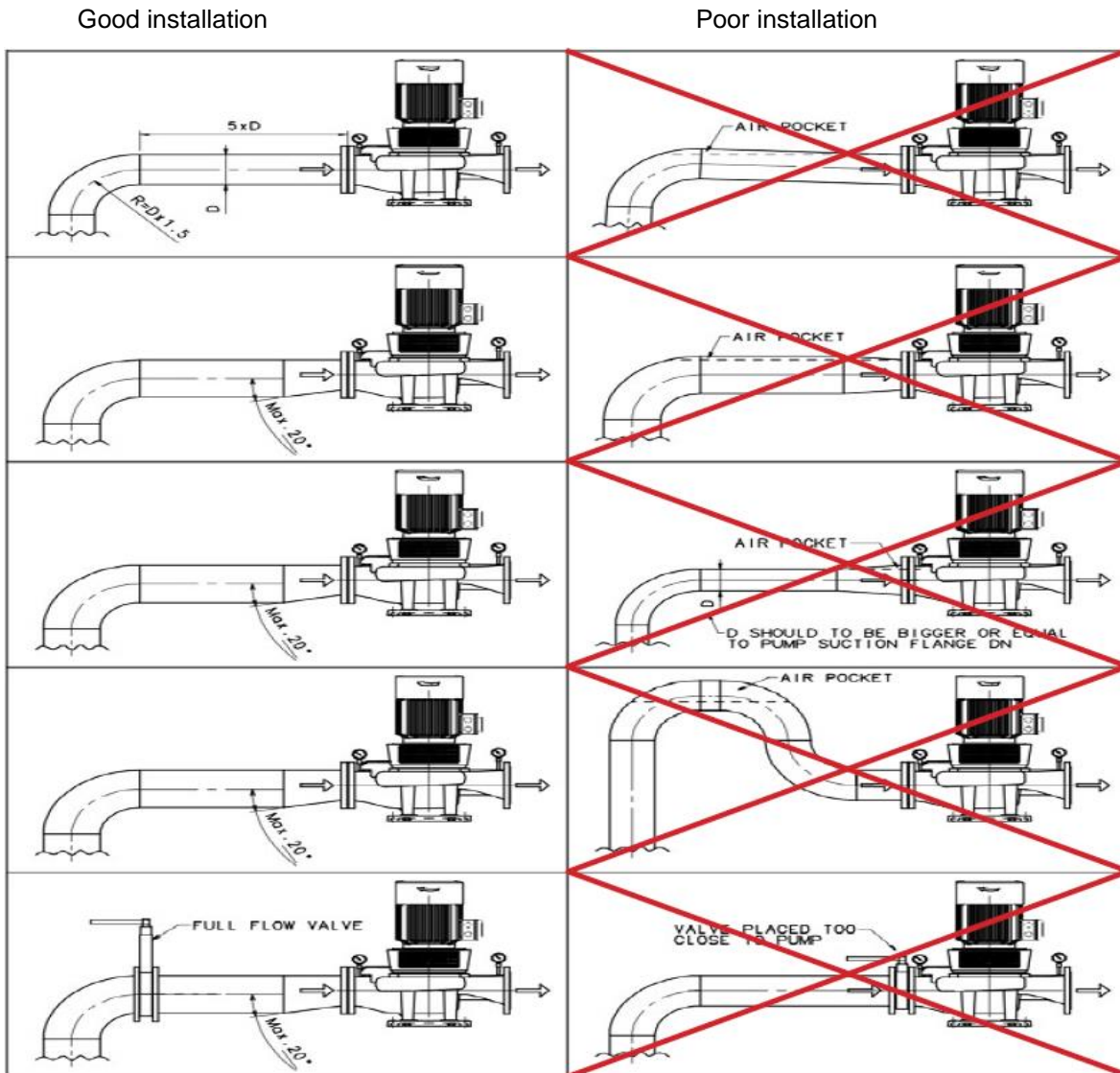

Figure 5-2: Land Base Installation

Pump installation foundation should be in good condition and shape.

- All the edges of pump foot have full contact with the supporting brackets.
- Pipes shall be connected correctly and not overloading the pump flanges. Refer to [chapter 4.1](#) regarding max. permissible loads on the pump flanges.
- Pipe support shall be designed according to the pipe forces at every possible operating condition, including cold/warm, empty/full, unpressurized/pressurized.
- All bolts on base plate / base frame shall be tightened with recommended torques.
- For Marine & Offshore installation, foundation should be made from proper steel plate or profile steel with enough stiffness to support pump to run stably and reduce potential vibrations.

Recommended design of pipes



Recommended flow velocity in pipeline

Flow velocity (v) in following ranges

Note: Higher velocities might be acceptable in some installations and/or for short term operation.

- $v < 3$ m/s at inlet side (note: $v < 1.5$ m/s in manifolds splitting flow to several pumps in parallel)
- $v < 6$ m/s at outlet side

Avoid impurities

Recommend installing filter and monitor device to avoid impurities into pump.

- Install a filter into the suction pipe.
- Install a differential pressure gauge to monitor impurity.

Bypass

The pump must not run against a closed valve as this will cause a rise in temperature / formation of steam in the pump which may cause damage to the pump.

If there is any special design of the pump running against a closed valve, ensure a minimum liquid flow through the pump by connection of a bypass or drain to the outlet pipe. The minimum flow rate must be at least 30% of maximum flow rate for short term operation, the flow rate and head are stated on the pump name plate. **Note:** Operation outside 70 to 120 % of BEP flow reduce the pump life (incl. shaft seal and pump bearings) significantly.

Allowable vibration levels on the pumps

As standard, DESMI centrifugal pumps with electric motor generate less than 2.8 mm/s vibration velocity (measured in 3 directions at motor flange level on vertical pumps) during a factory test. The pump and electric motor industry generally agrees that vibration levels above 7 mm/s are damaging – i.e. this will result in shorter lifetimes of e.g. bearings and/or shaft seals in pumps (and bearings in motors) than normally expected. This agrees with the recommendations in the international standard ISO10816-3.

Vibration prevention on vertical Pumps installed on ships.

High vibration levels at pump / motor top is a well-known issue in vertical pumps installed on ships.

Often external excited vibrations combined with the relative high Centre of Gravity compared with the size of the pump baseplate and/or the foundation stiffness below result in too high vibration levels in pump and motor top.

I.e. it is normally not the vibrations induced by the motor and/or the pump itself that causes problems (except if the pump or motor has mechanical problems and/or the pump is running with much higher flow than it is designed for – this can cause so high turbulence levels in pump and piping system that excessive vibrations occur).

Changing the structure can minimize the vibration level significantly - either by reinforcing the foundation stiffness below the base plate of the pump and/or by adding lateral supports at pump top / motor mounting flange level (the lateral supports will typically be the cheapest/fastest/easiest solution).

Whether this should be a rigid or a flexible support is not easy to determine since this depends on the actual installation and the available fixing points in the vessel.

In cases where the lateral supports are transferring hull vibrations (e.g. from main engine in ship) to the support connection points on pump or motor then a flexible element can then be added for

protection of the pump and motor unit.

If the motor weighs more than say two times the pump (often the case for e.g. small vertical DESMI NSL pumps with 2-pole motor running say 2980 or 3570 rpm) it is normally better to mount the lateral supports at the motor's lifting eye bolt holes (i.e. near the center of gravity for the motor).

Examples of DESMI vertical pumps with lateral supports bolted onto motor mounting flange (i.e. re-using existing bolt holes) are shown as below:

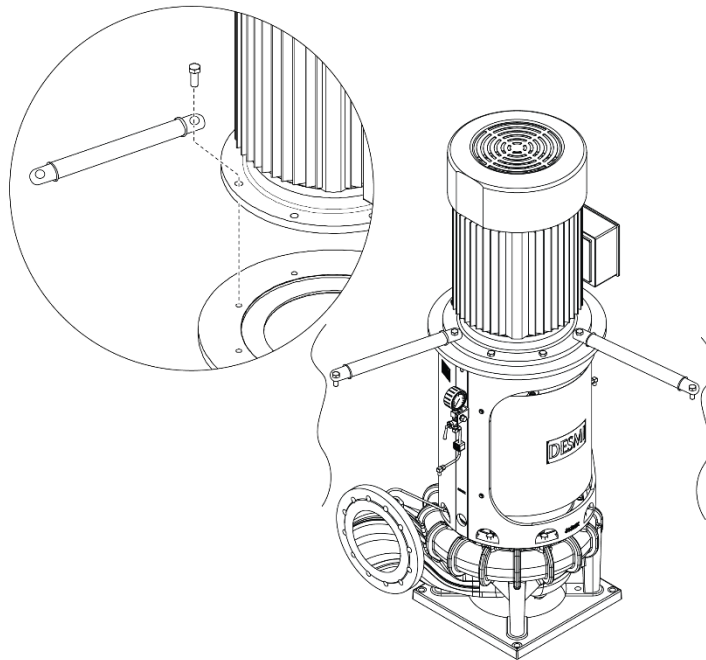

Figure 5-3: Examples of DESMI vertical pumps with lateral supports

DESMI recommends the following values for protective settings:

Location	Vibration alarm level (mm/s)	Vibration trip level(mm/s)
Pump	>7	>10
Motor (drive end)	>7	>10
Motor (non drive end)	>10	>15

Maximum suction up height (suction lift)

If the pump inlet pressure is lower than the vapor pressure of the pumped liquid, cavitation will occur. To avoid cavitation, a minimum pressure at the side of pump must be guaranteed.

The maximum suction up height should be lower than the following calculated value. If not, the pump will not work normally and might be damaged due to cavitation and/or deliver less flow and/or less differential pressure.

$$H = H_b - NPSHr - H_f - H_v - H_s$$

Here:

H_b = Barometric liquid head (m) = $P_b \times 10.2 / SG$ (m)

P_b = Atmospheric pressure (bar) (can normally be set as 1 bar – but might be significantly less).

SG = Specific Gravity (e.g. set as 1 for fresh water, 1.025 for seawater, 0.84 for diesel fuel)

In a closed system, P_b means system pressure (bar).

$NPSHr$ = Net positive suction head required (m) (read at actual flow on $NPSHr$ curve for pump)

H_f = Pipeline loss at the inlet (m)

H_v = Vapor pressure for actual liquid (m)

H_s = Safety margin, at least 0.5 meter recommended

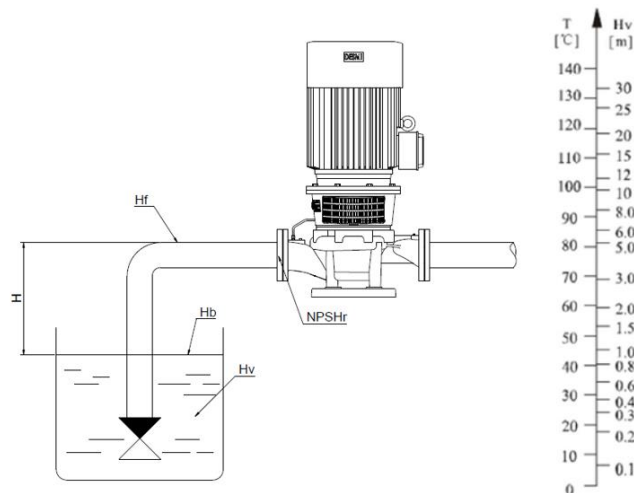

Figure 5-4: Suction up height

Service areas

To facilitate future servicing of pump and electric motor, lifting gear, such as access for cranes, lifting points, ceiling beams or other approved equipment for the purpose, should be installed. Carefully consider where the pump installation will be placed, as transportable approved lifting gear often needs considerable space.

* If there is no permanently-installed lifting gear, an approved lifting beam is required.

*Note: Some pumps have a service area underneath.

Insulation

Pumps supplied by DESMI can in general be insulated for heat or cold except at the top of the pump housing

- i.e. up to the base flange on the motor bracket as shown below. No holes or screen openings on the motor bracket can be covered by insulation.

An electric motor will become hotter if mounted on a fully insulated pump. The ball bearings and/or windings coils in the motor can overheat if a pump is insulated all the way up to the motor flange.

Unrestricted ventilation of the motor bracket is therefore necessary to provide sufficient cooling of pump and motor bearings – both in pumps with bearings (/02 or Spacer version) and without bearings (/12 version).

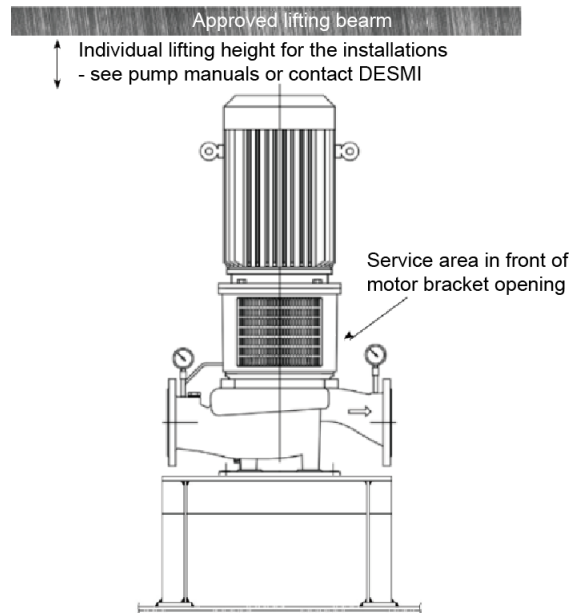

Figure 5-5: Service areas

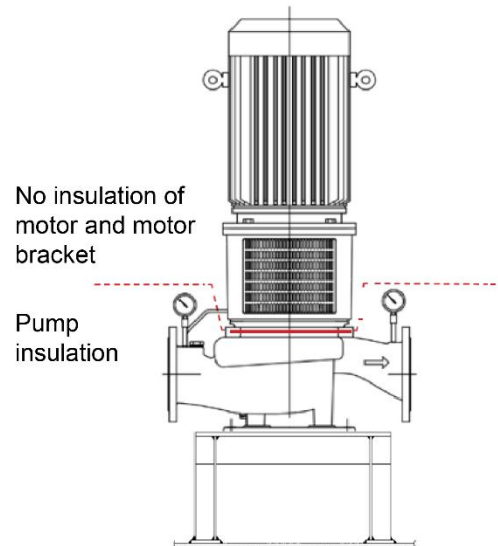

Figure 5-6: Insulation

Ventilation

Ambient conditions-

Pay attention to the correct arrangement of air feed and discharge lines so that:

- The pump is efficiently ventilated.
- The room temperature not exceeding 45 °C.
- Ensure airflow around the pump motor.

The rating of the electrical apparatus is critical in this respect.

Operation under other ambient conditions to be agreed with the manufacturer.

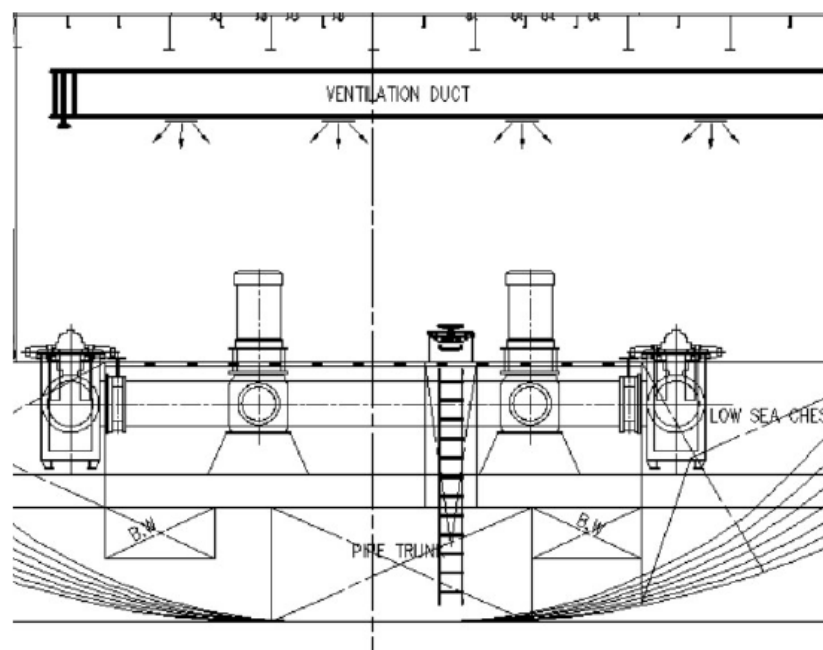

Figure 5-7: Ventilation



NOTE: If the admissible temperature are exceeded, additional measures must be taken. Maintenance intervals and maintenance measures may have to be adjusted accordingly.

6. COMMISSIONING, START-UP AND SHUTDOWN

6.1. Prerequisites for commissioning / start-up

Before commissioning / starting up the pump set, make sure that the following conditions are met:

- The pump set is properly connected to the power supply and is equipped with all protection devices.
- The pump is primed with the fluid to be handled. The pump is vented.
- The direction of rotation is checked.
- All auxiliary connections required are connected and operational.
- If re-greasable then motor bearings to be greased acc. to motor manual before starting the pump ! Any pump bearing(s) are fully greased from DESMI factory = do not re-grease any pump bearing(s) before scheduled running hours in re-grease table in Section 8 are obtained).
- After prolonged shutdown of the pump (set), the activities required for returning the pump (set) to service are carried out.

6.2. Priming and venting the pump



DANGER

EXPLOSION HAZARD!

Incorrect start-up of the pump will cause potentially explosion atmosphere inside the pump, which will cause death or serious injury.

Before starting up the pump, vent the suction line and the pump, and prime them with the fluid to be handled.

CAUTION

RISK OF PROPERTY DAMAGE!

Dry running will cause increased wear to the pump.

Do not operate the pump set without liquid fill.

Do not close the shut-off element in the suction line and / or supply line during pump operation.





NOTE: For design-inherent reasons, some unfilled volume in the hydraulic system cannot be excluded after the pump is primed for commissioning/start-up. However, once the motor is started up the pumping effect will immediately fill this volume with the fluid handled.

1. Vent the pump and the suction line and prime both with the fluid to be handled.
2. Fully open the shut-off element in the suction line.
3. Fully open all auxiliary feed lines (barrier fluid, flushing liquid, etc.), if any.
4. Open the shut-off element, if any, in the vacuum balance line, and close the vacuum-tight shut-off element, if any.

Venting and priming

Automatic venting and priming system is designed for centrifugal pumps to prevent dry running while the liquid level is below the pump inlet.

When the centrifugal pump is turned on, only the automatic priming system will be activated. After the time limit relay sequence is completed, the centrifugal pump is also activated. As soon as the centrifugal pump builds up the necessary discharge pressure, the priming system is switched off via the pressure switch.

DESMI priming unit has two types: priming pump and priming air ejector.

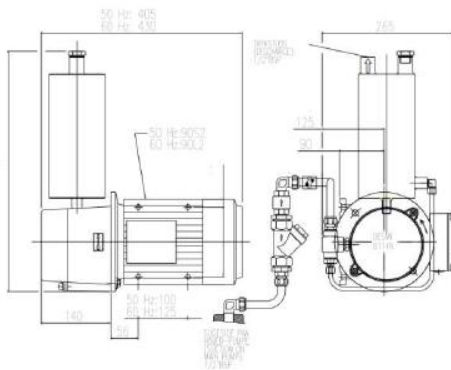

Figure 6-1: Priming pump B114N

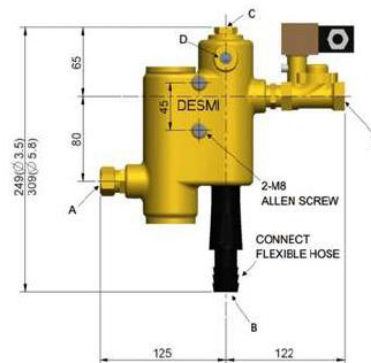

Figure 6-2: Priming air ejector

Please see manual for more details.

<http://www.desmi.com/media/fo2dilig/t1488uk.pdf>

<http://www.desmi.com/media/dtojxa0h/t1521uk.pdf>

6.3. Start up

⚠ DANGER



EXPLOSION HAZARD!

LEAKAGE OF HOT OR TOXIC FLUIDS!

If the pump is operated with the suction and/or discharge line closed will cause incorrect pressure and temperature. Hot or hazard fluids under pressure will cause death or serious injury.

Do not operate the pump with the shut-off elements in the suction line and/or discharge line closed.

Only start up the pump set with the discharge-side shut-off element slightly or fully open.



⚠ DANGER



EXPLOSION HAZARD!

DAMAGE TO THE PUMP SET!

High temperature due to dry running or too much gas content in the fluid handled will cause death or serious injury.

Do not operate the pump set without liquid fill.

Prime the pump according to operating instructions.

Always operate the pump in the permissible operating range.



CAUTION



RISK OF PROPERTY DAMAGE!

Abnormal noises, vibrations, temperatures or leakage could cause damage to the pump.

Stop the pump (set) immediately.

Eliminate the causes before returning the pump set to service.



NOTE:

A centrifugal pump will not function until it is filled with liquid between the foot valve and somewhat above the impeller of the pump.

The liquid also serves as coolant for the shaft seal. In order to protect the shaft seal, the pump must not run dry.

For safety reasons the pump is only allowed to operate against closed discharge valve for a short time (max. 5 minutes and at a max. temperature of 80 °C for standard pumps). Otherwise there is

a risk of damage to the pump and, at worst, of a steam explosion. If the pump is not monitored, the installation of a safety device is recommended.

Check in the electric motor manual if the bearings in the motor needs be lubricated with grease before first start-up.

On pumps not running, the shaft shall be rotated at least 2-3 times monthly to avoid standstill damage to shaft seal and bearings. If the pump is filled with liquid, it can alternatively be started up shortly.

In special applications, it may require more frequent shaft rotation or start-up in order to avoid seizing of the impeller and/or the shaft seal.

In pressurized systems, the shaft seal often leaks a bit during standstill – in most cases the leakage stops shortly after the pump is started up.

It is not recommended to lead liquid (either one way or the other) through a passively rotating pump, as this may damage the shaft seal.

For the sake of the shaft seal lifetime, it is recommended to run at least 300 rpm and use max. 1 minute on acceleration from 0 to 300 rpm and max. 1 minute on deceleration from 300 to 0 rpm.

6.3.1. Start-up procedure

Before starting the pump check that:

- The shaft rotates freely without jarring sounds.
- The pump casing and the suction line are filled with liquid.

Start the pump for a moment to check the direction of rotation. If the direction is correct (i.e. in the direction of the arrow) the pump may be started.

- The system piping is cleaned.
- The pump, suction line and inlet tank, if any, are vented and primed with the fluid to be pumped.
- The lines for priming and venting are closed.

CAUTION

RISK OF PROPERTY DAMAGE!



Start-up against open discharge line could lead to motor overload, which could damage the motor.

Make sure that the motor has sufficient power reserves.

Use a soft starter.

Use speed control.

1. Fully open the shut-off element in the suction head / suction lift line.
2. Close or slightly open the shut-off element in the discharge line.
3. Start up the motor.
4. Immediately after the pump reaches the full rotational speed, slowly open the shut-off element in the discharge line and adjust it to comply with the duty point.

6.4. Checking the shaft seal

The mechanical seal only leaks slightly or invisibly (as vapor) during operation. Mechanical seals are maintenance-free.

6.5. Shut down

CAUTION



RISK OF DAMAGING THE SHAFT SEAL!

Heat build-up inside the pump could damage the shaft seal.

Stop the heat source, and always allow the fluid handled to completely cool down after the pump set stops.

The shut-off element in the suction line is and remains open.

1. Close the shut-off element in the discharge line.
2. Switch off the motor and make sure the pump set runs down smoothly to a standstill.



NOTE: If the discharge line is equipped with a check valve, the shut-off element in the discharge line may remain open, provided the site's requirements and regulations are taken into account and observed.

For prolonged shut down periods:

1. Close the shut-off element in the suction line.
2. Close the auxiliary connections.

CAUTION



RISK OF PROPERTY DAMAGE!

Liquids may freeze during long-term shutdown periods, which could damage the pump.

Drain the pump and the cooling / heating chambers (if any), or take other actions to prevent them from freezing.

6.6. Operating limits

The working range in [chapter 4.1](#) and technical data in [chapter 4.2](#) to be complied with.

⚠ DANGER



EXPLOSION HAZARD!

LEAKAGE OF HOT OR TOXIC FLUID HANDLED!

When you operate the pump, incorrect pressure, temperature, fluid handled and speed will cause damage to property, death or serious injury.

Observe the operating data in the order documentation.

Do not use the pump to handle unauthorized fluids.

Do not operate the pump against a closed shut-off element for long periods

Without getting written approval from DESMI, do not operate the pump in incorrect condition (for example, temperature, pressures or speeds exceeding those specified in the order documentation or on the name plate).



CAUTION



RISK OF PROPERTY DAMAGE!

When you operate the pump, incorrect ambient temperature could damage the pump (set).

Observe the specified limits for permitted ambient temperatures.

6.7. Frequency of starts

⚠ DANGER



EXPLOSION HAZARD!



DAMAGE TO THE MOTOR!

Too high temperature of the motor surface may cause explosion, which will cause damage to the motor, death or serious injury.

For explosion-proof motors, observe the frequency of starts in manufacturer's documents.

The frequency of starts is usually determined by the maximum temperature increase of the motor. This largely depends on the power reserves of the motor in steady state operation and on the starting conditions (DOL, star-delta, moments of inertia, etc.). If the start-ups are evenly spaced over the period indicated, the following limits serve as orientation for start-up with the discharge-side gate valve slightly open:

Impeller material	Maximum number of start-ups
	[Start-ups/hour]
Bronze (NiAlBz/CC333G)	6
Stainless steel (1.4410/1.4436)	6

CAUTION



RISK OF PROPERTY DAMAGE!

Re-starting while motor is still running could damage the pump (set).

Do not re-start the pump set before the pump motor is fully stopped.

6.8. Fluid handled

6.8.1. Flow rate

Recommend operate pump at 70 to 120% of BEP flow for high efficiency, operation outside the range reduce the pump life (incl. shaft seal and pump bearings) significantly.

6.8.2. Density of fluid handled

The pump input power changes in proportion to the density of the fluid handled.



CAUTION

RISK OF PROPERTY DAMAGE!

Too high density of the fluid pumped could lead to motor overload, which could damage the motor.

Observe the density information in the order documentation.

Make sure that the motor has sufficient power reserves.

6.8.3. Abrasive fluids

Do not exceed the maximum permissible solids content specified in the order documentation. When the pump handles fluids containing abrasive substances, increased wear of the hydraulic system and the shaft seal are to be expected. In this case, reduce the commonly recommended inspection intervals.

6.9. Decommissioning / out of service

When the pump is decommissioned or put out of service for a longer period of time, it has to be stored properly.

The pump (set) remains installed

Sufficient fluid is supplied for the operation check run of the pump.

1. Start up the pump (set) regularly between once a month and once every three months for approximately five minutes during prolonged shutdown periods. This will prevent the formation of deposits within the pump and the pump intake area.

The pump (set) is removed from the pipe and stored

The pump was properly drained and the safety instructions for dismantling the pump was observed.

1. Spray-coat the inside wall of the pump casing, and in particular the impeller clearance areas, with a preservative.
2. Spray the preservative through the suction and discharge nozzles. It is recommended to close the pump nozzles (e.g. with plastic caps or similar).

3. Apply oil or grease (silicone-free oil and grease, food-approved if required) on all exposed machined parts and surfaces of the pump (with silicone-free oil and grease, food-approved if required) to protect them against corrosion.

Observe the additional instructions.

If the pump set is to be stored temporarily, only preserve the wetted components made of low-alloy materials. Commercially available preservatives can be used for this purpose. Observe the manufacturer's instructions for application / removal.

Observe any additional instructions and information provided.

6.10. Return to service

For returning the pump to service, observe the sections on commissioning / start-up and the operating limits. In addition, Do all servicing / maintenance operations before returning the pump (set) to service.

WARNING



PERSONAL INJURY HAZARD!

Moving parts or escaping fluid could cause death or serious injury.

Immediately after the work is complete, re-install and/or re-activate all safety-relevant and protective devices.



NOTE: *If the pump has been out of service for more than one year, replace all elastomer seals.*

7. TROUBLESHOOTING

It is often difficult to calculate a manometric delivery head in advance. It is, however, decisively important to the quantity of liquid delivered.

A considerably smaller delivery head than expected will increase the quantity of liquid delivered, causing increased power consumption and perhaps cavitation in pump and piping. In the pump, the impeller may show signs of heavy erosion caused by cavitation (corrosion) which may at times render an impeller unfit for use in a very short time. Similar erosions also occur in pipe bends and valves elsewhere in the piping system.

Therefore, after start-up, it is necessary to check either the quantity of liquid delivered or the power consumption of the pump e.g. by measuring the current intensity of the connected motor. Together with a reading of the differential pressure, the quantity of water delivered can be determined against the characteristics of the pump.

If the pump does not function as intended, please proceed according to the fault-finding list. Bear in mind, though, that the pump was carefully checked and tested at the factory and that the majority of faults stem from the piping system.

FAULT	CAUSE	REMEDY
The pump has no or too low capacity	1. Wrong direction of rotation	Change direction of rotation to clockwise when viewed from shaft end (the direction of the arrow)
	2. Piping system is choked	Clean or replace the piping system
	3. The pump is choked	Clean the pump
	4. Suction line leaks	Find the leakage, repair the fault, non-return valve not submerged
	5. Pump takes air	
	6. Suction lift is too high	Check data sheet Q/H curve and NPSH or contact DESMI
	7. Pump and piping system wrongly dimensioned	As 5
The pump uses too much power	1. Counter-pressure is too low	Insert orifice plate or check valve / Contact DESMI
	2. The liquid is heavier than water	Contact DESMI
	3. Foreign body in pump	Dismantle the pump, remove the cause

FAULT	CAUSE	REMEDY
	4. Electric motor is running on 2 phases	Check fuses, cable connections, and cables
The pump makes noise	1. Cavitation in pump	Suction lift is too high / Suction line wrongly dimensioned / Liquid temperature is too high

7.1. Mechanical seal failure analysis

Description of possible failure	Impacts on the pump/system	Indications of failure	How to avoid
Pump settled (due to seizing sliding rings in mechanical shaft seal) due to standstill after storage	Mechanical seal failure/leaking after short time	1. Initial leaking after first start up that does not stop after short time	<ol style="list-style-type: none"> 1. Ensure correct storage of pumps 2. Preventive maintenance to be followed for long term storage 3. Rotate pump carefully by hand prior to first start up, to ensure integrity of mech. shaft seal
Pump settled (due to seizing sliding rings in mechanical shaft seal) due to standstill in system / stored with water inside for longer duration of time	Medium could change properties when standstill in pump based on the environment and type of medium	<ol style="list-style-type: none"> 1. Higher power consumption than calculated short time after startup 2. Leakage from mech. shaft seal after start up 	<ol style="list-style-type: none"> 1. Rotate the pump regularly, to avoid seizing 2. If not possible, pumps should be drained
Lack of NPSH available vs. NPSH required	Cavitation duty, creating vibration and mechanical damage	<ol style="list-style-type: none"> 1. Vibration and noise from the pump 2. Wear on impeller/seal ring, and possible leaking mec. seal 	<ol style="list-style-type: none"> 1. Make sure to have sufficient NPSHa at all times

Description of possible failure	Impacts on the pump/system	Indications of failure	How to avoid
Bad piping and fitting arrangement	Turbulent flow and vibrations in the system	<ol style="list-style-type: none"> 1. Vibration, and noises from the piping system. 2. Possible premature leakage from mec. seal 	<ol style="list-style-type: none"> 1. Check piping and fitting arrangement is in accordance with CEN standards. 2. Should be reviewed and approved in design phase
Starvation / lack of inlet flow	Pump not receiving enough liquid to give a stable operation, pump not giving sufficient flow. Could cause insufficient liquid film in seal and cause dry running	<ol style="list-style-type: none"> 1. Vibrations in the pump and unstable operational readings 2. Flow not increasing at higher pump speed. 3. Possible leaking mechanical seal 	<ol style="list-style-type: none"> 1. Make sure all valves are open, and no filters are clogged etc. 2. Check piping and fittings 3. Other consumers on the same suction line might cause problems
High liquid velocities	Vibrations and turbulent flow in the system	<ol style="list-style-type: none"> 1. Noise, vibrations and lack of pump performance. 2. Possible leaking mech. shaft seal 	<ol style="list-style-type: none"> 1. Make sure to have piping dimensioned for specified flow rating 2. In general liquid velocity should increase from piping inlet through the pump to the outlet
External excited vibrations from the vessel or piping system	If above recommended levels (7mm/s) it can lead to premature mechanical failures	<ol style="list-style-type: none"> 1. Visual and measured vibration levels. 2. Leaking mech. shaft seal 	<ol style="list-style-type: none"> 1. Install vibration reducing components such as flexible bellows at inlet/outlet, vibration pads on base plate, horizontal lateral support on motor

Description of possible failure	Impacts on the pump/system	Indications of failure	How to avoid
Dry running of the pump – closed inlet/discharge valve	Pump should never be run dry, this will damage the mechanical seal in very short time, and will cause bearing failure and total pump breakdown	<ol style="list-style-type: none"> 1. Valves closed, quickly generating heat in the pump, high noises, increased power consumption before total breakdown 	<ol style="list-style-type: none"> 1. Always make sure pump is never operated dry (check regularly that any priming systems are working) and/or with closed suction valves. 2. Can operate for a short time towards shut discharge valve, refer to the chapter 6.3
Operating outside recommended QH area (70-120% of BEP)	Can lead to premature mechanical failure and further damage	<ol style="list-style-type: none"> 1. Readings of operational/log data. 2. At least diff. pressure, power and pump speed. Compare with design specification 	<ol style="list-style-type: none"> 1. Continuously monitoring the operation. 2. Use limitations and alarms in the control system – min/max rpm, flow, pressure
Medium and/or pressure and/or liquid temperature not according to specification	Depends on specification and actual difference in this	<ol style="list-style-type: none"> 1. Abnormal wear and corrosion in the pump. 2. Leaking mechanical seal 	<ol style="list-style-type: none"> 1. Mechanical seal material and properties are specified based on medium and conditions. 2. Difference in spec. might require a different mechanical seal / pump materials

Description of possible failure	Impacts on the pump/system	Indications of failure	How to avoid
Water hammer / hydraulic shocks	Cause a tremendous pressure shock to the pump and system that could cause serious damage	<ol style="list-style-type: none"> 1. Shutting down and closing valves creates noise and give hydraulic shocks to the whole system 2. Will cause mechanical damage, not only to mechanical seals 	<ol style="list-style-type: none"> 1. Have sufficient ramp down time and avoid closing valves too fast. 2. Correct usage of non-return valves
Pump parts (e.g. vent/flush piping) in pump clogged up	Missing supply of liquid for cooling/lubrication of mechanical shaft seal and/or missing automatic air venting of shaft seal chamber	<ol style="list-style-type: none"> 1. Seal leakage after short time 	<ol style="list-style-type: none"> 1. Ensure proper filters / mesh size on suction side of pump. 2. If solids sediment inside pump parts (e.g. piping) they must be disassembled and cleaned inside regularly
Production faults from maker	Normally discovered during testing at the factory	<ol style="list-style-type: none"> 1. Seal leakage after short time 	<ol style="list-style-type: none"> 1. Hydrostatic (leakage) and performance test 3.1 or 3.2. 2. Specific classification requirement testing to exclude possibility of production faults

Troubleshooting:

For the maker to begin troubleshooting we need at least the supporting documents “letter of investigation of pump failure” and possibly “commissioning check list” to be properly filled in. We recommend retrieving information in the following order (to optimize the time usage):

1. Description of the failure and pictures of the damage together with operational readings/log data. This can eliminate or verify many of the possible failures and is the easiest and best way to begin troubleshooting.
2. If nothing can be concluded after point no. 1. pictures and description of the piping system (especially suction piping) should be provided. Also verify if there has been any observation of excessive vibrations or noise coming from the vessel/pump/system.
3. If we cannot conclude possible root cause from information received under point 1. or 2. it might be necessary to send a service engineer to investigation and further troubleshooting.

Other considerations:

- The mechanical seal is normally not covered under warranty/guarantee, as this is considered a “wear and tear” part.
- A mechanical seal might have some initial leakage like drops or a small trickle during first start-up as it has not yet fully settled and become tight. Observe the mechanical seal to see if leakage stops, if not it could be enough to dismantle the mechanical seal and clean it properly to stop the leakage.
- Mechanical seal is the single most exposed/vulnerable part in a 1-stage centrifugal pump; hence a mechanical seal failure is often the first indication of problems. Failure can occur in only a few minutes running in the wrong conditions, so it is often difficult to find root cause of damage if we do not have complete set of information from the vessel.
- In order to avoid serious damage to pumps make sure to follow the maintenance recommendations given by the maker. Inspect the pumps regularly for initial leakage. If leakage is observed it is important to take action to replace seal as quickly as possible.
- Check regularly that the shaft seal leak drain hole in the rear cover (or in bearing cover / bracket on some pump designs) is not clogged up. A clogged shaft seal leak hole can lead to premature bearing failure due to water rising up into the pump ball bearings when the shaft seal is worn out and/or damaged.
- We always recommend having spare mechanical seal (spare part kit) onboard the vessel at all time to avoid standstill of pumps in case of seal failure.

8. INSPECTION AND SERVICE PLAN

8.1. Supervision of operation



DANGER

EXPLOSION HAZARD!

Potentially explosive atmosphere inside the pump will cause death or serious injury.

The pump internals in contact with the fluid to be handled, including the seal chamber and auxiliary systems, must be filled with the fluid to be handled at all times.

Provide sufficient inlet pressure.

Provide an appropriate monitoring system.



DANGER

EXPLOSION HAZARD!

LEAKAGE OF HOT OR HAZARD FLUIDS!

DAMAGE TO THE PUMP SET!

RISK OF BURNS AND FIRE HAZARD!

Damaged or deformed shaft seal will cause damage to the pump, death or serious injury.

Do the maintenance on the shaft seal regularly.



DANGER

EXPLOSION HAZARD!

FIRE HAZARD!

DAMAGE TO THE PUMP SET!

RISK OF BURNS!

Excessive temperature as a result of bearings running hot or defective bearing seals will cause damage to the pump, death or serious injury.

Regularly check the lubricant level.

Regularly check the rolling-element bearings for running noises.

⚠ DANGER



EXPLOSION HAZARD!

FIRE HAZARD!

DAMAGE TO THE PUMP SET!



LEAKAGE OF HOT AND/OR TOXIC FLUIDS!

Incorrectly serviced barrier fluid system will cause damage to the pump, death or serious injury.

Regularly service the barrier fluid system.

Monitor the barrier fluid pressure.

CAUTION



RISK OF PROPERTY DAMAGE!

Dry running will cause increased wear to the pump

Do not operate the pump set without liquid fill.

Do not close the shut-off element in the suction line and/or supply line during pump operation.

CAUTION



RISK OF PROPERTY DAMAGE!

Too high temperature of fluid handled could damage the pump.

Do not operate the pump against a closed shut-off element for long periods.

Observe the temperature limits in the section on operating limits. ([chapter 2.8.4](#))

While the pump is in operation, observe and check the following:

- The pump must run quietly and free from vibrations at all times.
- Check the shaft seal.
- Check the static seals for leakage.
- Check the rolling element bearings for running noises.

Vibrations, noise and an increased incurrent input occurring during unchanged operating conditions indicate wear.

- Monitor the correct functioning of any auxiliary connections.
- Monitor the stand-by pump.

To make sure that the stand-by pumps are ready for operation, start them up once a week.

- Monitor the bearing temperature.

The bearing temperature must not exceed 85 °C (measured at the motor housing).

Inspect the shaft seal for leaks at regular intervals.

- Before inspection of a pump without guard, check that the pump cannot be started unintentionally.
- The system is to be without pressure and drained of liquid.
- The repairman must be familiar with the type of liquid which has been pumped as well as the safety measures is to be taken when handling the liquid.

CAUTION



RISK OF PROPERTY DAMAGE!

Operation of the pump at incorrect bearing temperature could damage the pump.

Make sure that the bearing temperature of the pump (set) is not more than 90 °C (measured on the outside of the motor housing).



NOTE: After commissioning, increased temperatures may occur at grease-lubricated rolling element bearing due to the running-in process. The final bearing temperature is only reached after a certain period of operation (up to 48 hours depending on the conditions).

On pumps with bearing (/ -02 design or Spacer), the drain hole at the mechanical shaft seal must be inspected regularly (see drawing example below). Clean the drain hole as needed. If the drain hole clogs up, leaking liquid and/or vapor from the shaft seal can be forced up into the bearing unit, which can result in a much shorter bearing life than normal.

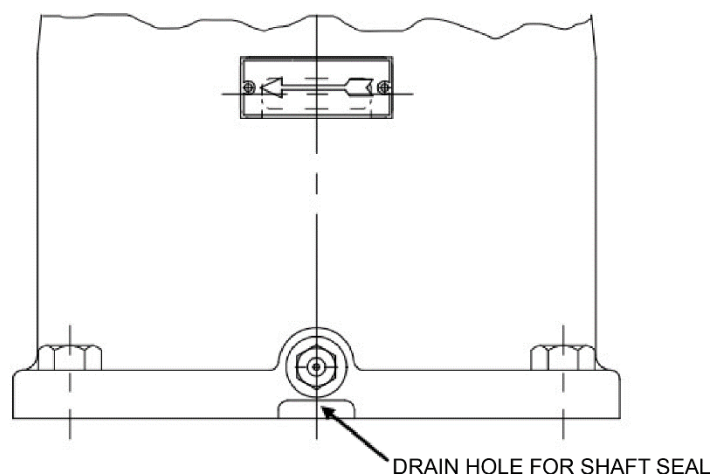

Figure 8-1: Drain hole for shaft seal

Inspection and maintenance intervals for normal applications:

(Half intervals are recommended for a new application – until required intervals can be determined for the actual application)

(If daily inspection is not done remote monitoring of pump is recommended – e.g. via temperature sensors on pump bearings)

Inspect (I) or Maintain (M) at the indicated calendar time or run time interval – whichever comes first	Daily	Weekly	Monthly	8000 running hours or 12 months	25000 running hours or 60 months
Shaft seal leakage (normally less than 0.5 mL/hour (~10 drops/hour) – if more than 5 mL/hour shaft seal replacement is recommended)	I				
Motor ampere and/or power consumption within normal range	I				
Unusual noise	I				
Unusual vibration (normally less than 2.8 mm/s from pump itself – and less than 7 mm/s incl. external excited vibrations)	I				
Pressure gauge readings to be within normal range (i.e. keep flow within 70 to 120% of BEP flow if allowed by NPSHa <> NPSHr, see note below)	I				
Unusual bearing temperatures (normally less than 85°C)		I			
Check (clean if required) drain hole for shaft seal			I (M)		
For pump with bearing(s): Check gap between coupling and bearing bracket/cover – to be at least 1 mm (see Section 10.3.8)			I		
Pumps not running: Rotate pump shaft 2 to 3 revolutions or start shortly (if pump is filled with liquid)			M		
Regrease pump and/or motor bearings	Refer to the following pages and motor manual (if motor bearings are re-greaseable)				
Spacer coupling elastomer(s)				I	
Replace mechanical shaft seal and V-ring					M
Replace pump bearings					M
Replace Spacer coupling elastomer(s)					M

Note: Operation outside 70 to 120 % of BEP flow reduce the pump life (incl. shaft seal and pump bearings) significantly.

BEARINGS in 12 combination

The life depends on the relubrication, size and quality of the bearing in the motor.

BEARINGS in 02 combination

Ø215/265: The bearing is dimensioned for a nominal (i.e. only obtainable for ideal greasing and operating conditions) life of 25,000 working hours. The bearing is lubricated for life and requires no attention, but is to be replaced in case of noise or bearing wear.

Ø330/415/418/465/525: The bearing is dimensioned for a nominal (i.e. only obtainable for ideal greasing and operating conditions) life of 100,000 working hours and is to be relubricated according to the below table. The bearing is to be replaced in case of noise or bearing wear.

Assembly \ Pump	Ø330/415/418/465/525
Light bearing housing (single-row ball bearing)	The bearing is to be relubricated through the lubricator nipple (84) in the bearing cover (15). In connection with replacement, the bearings are to be mounted with the RS-sealing facing downwards, fill the bearing itself with grease and place a grease bead on the bearing towards the shaft in a quantity corresponding to the table below.
Heavy bearing housing (two angular ball bearings):	The bearings are to be relubricated through the lubricator nipple (84) in the bearing cover (15). Fill the bearings with grease and place a grease bead on the bearing towards the shaft in a quantity corresponding to the table below.

Pump	Assembly	Interval (running hours)	Quantity
NSL80-330 NSL100-330 NSL125-330 NSL100-415 NSL125-415	Light bearing housing	4500 hours	30 g

Pump	Assembly	Interval (running hours)	Quantity
NSL150-330 NSL200-330 NSL250-330 NSL150-415	Heavy bearing housing	4500 hours	40 g
NSL200-415 NSL250-415 NSL300-415 NSL300-418	Heavy bearing housing	4500 hours	50 g
NSL300-465 NSL200-525 NSL250-525 NSL300-525 NSL350-525	Heavy bearing housing	4500 hours	80 g

BEARINGS in 13 combination and 14 combination

Ø215/265: The bearings are dimensioned for a nominal (i.e. only obtainable for ideal greasing and operating conditions) life of 25,000 working hours and are to be relubricated according to the table below.

Ø330/415/418/465/525: The bearings are dimensioned for a nominal (i.e. only obtainable for ideal greasing and operating conditions) life of 100,000 working hours and are to be relubricated according to the table below.

Assembly \ Pump	Ø215/265	Ø330/415/418/465/525
Light bearing housing (13 combination)	The bearings are lubricated for life and require no attention but are to be replaced in case of noise or bearing wear. In connection with replacement, the lower bearing is to be mounted with an RS - sealing facing downwards, fill the bearing itself with grease and place a grease bead on the	The bearings are relubricated through the lubricator nipples (84) at top and bottom of the bearing housing (18). In connection with replacement, the bearings are to be mounted with the RS-sealing facing downwards, fill the bearing itself with grease and place a grease bead on the

Pump Assembly	Ø215/265	Ø330/415/418/465/525
	bearing towards the shaft in a quantity corresponding to the table below.	bearing towards the shaft in a quantity corresponding to the table below.
Heavy bearing housing (14 combination)	Only the upper bearing (15) is lubricated for life, whereas the lower is to be relubricated through the lubricator nipple (84) in accordance with the table below. The replacement of bearings is to be made under the same conditions and according to the same procedure as for 13 combination, however, the RS - sealing is not to be considered.	Both bearings are relubricated through lubricator nipples (84) at top and bottom of the bearing housing (18). See instructions for ø215/265. The top bearing (15) is to be mounted with the RS - sealing facing downwards, fill the bearing itself with grease and place a grease bead on the bearing towards the shaft in a quantity corresponding to the table below.

Pump	Assembly	Interval (running hours)	Quantity Bottom bearing (13)	Quantity Top bearing (15)
ø215/265	Light bearing housing	Lubricated for life	40 g	Lubricated for life
ø215/265	Heavy bearing housing	8000 hours	65 g	Lubricated for life
NSL80-330 NSL100-330 NSL125-330 NSL100-415 NSL125-415	Light bearing housing	4500 hours	30 g	15 g
NSL150-330 NSL200-330 NSL250-330 NSL150-415	Heavy bearing housing	4500 hours	40 g	20 g

Pump	Assembly	Interval (running hours)	Quantity Bottom bearing (13)	Quantity Top bearing (15)
NSL200-415 NSL250-415 NSL300-415 NSL300-418	Heavy bearing housing	4500 hours	50 g	25 g
NSL300-465 NSL200-525 NSL250-525 NSL300-525 NSL350-525	Heavy bearing housing	4500 hours	80 g	35 g

If the pump liquid temperature is below 80 °C, the following types of grease are recommended:

ESSO	Beacon 2
BP	Energrease LS EP 2
Shell	Gadus S5 V100 2
Mobil	Mobil lux grease EP 2
Castrol	Spheerol AP 2 or AP 3
Texaco	Multifak EP 2
Q8	Rembrandt EP 2 or Rubens
Statoil	UniWay Li 62
GULF	GulfSea HYPERBAR LC3

If the pump liquid temperature is above 80 °C, high-temperature grease is recommended, e.g. SKF LGHP2.

DESMI use SKF LGHP2 as standard.

Vibration levels higher than 7 mm/s at pump bearing are considered damaging and will normally result in significantly shorter grease and/or bearing life – especially for pumps not running. Hence shorter re-greasing intervals might be required for pumps installed where external excited vibration levels can be higher than 7 mm/s.



NOTE: Relubrication can cause a (usually temporary) bearing temperature rise of up to approx. 20°C - especially by mixing different types of grease and / or by overlubricating the bearing.



NOTE: Grease used for re-greasing must be compatible with the grease in the bearing unit!

8.2. Inspection work

DANGER



FIRE AND EXPLOSION HAZARD!

Too high temperature caused by friction, impact or frictional sparks can cause fire, and if not avoided, will lead to death or serious injury.

Regularly check the coupling guard regarding screws being tightened and/or regarding deformation for ensuring sufficient distance from rotating parts.

8.2.1. Cleaning filter

CAUTION



RISK OF PROPERTY DAMAGE!

Incorrect inlet pressure due to clogged filter in the suction line could damage the pump.

Monitor contamination of filter with suitable instruments (for example, using differential pressure gauge).

Clean the filter at appropriate intervals.

8.2.2. Drainage and cleaning

WARNING



ENVIRONMENTAL HAZARD!

Hot fluids, consumables and supplies are hazardous to health and to the environment.

Collect and properly dispose of flushing fluid and any residues of the fluid handled.

Wear safety clothing and a protective mask.

Dispose of all fluids in accordance with local regulations.

1. Drain the fluid handled by dismantling the pipe plug (3) at the bottom of the pump.
2. Always flush the system if it has been used for handling noxious, explosive, hot or other

hazardous fluids.

3. Always flush and clean the pump before transporting it to the workshop.
4. Provide a certificate of decontamination for the pump.

9. DISMANTLING THE PUMP SET

DANGER



IGNORING INSTRUCTIONS HAZARD!

Insufficient preparation of work on the pump (set) will cause death or serious injury.

Properly shut down the pump set. ([See chapter 6.5](#))

WARNING



SPECIAL SKILLS REQUIRED!

Repair and maintenance procedures require professional knowledge and thorough training regarding the tasks and working methods.

Do not do any repair or maintenance tasks without proper training.

Always follow the instructions.

Use appropriate personal protective equipment, depending on the task.

WARNING



HOT SURFACE HAZARD!

Touching any part of a hot pump can cause severe injury.

Always allow the pump set to cool down to ambient temperature.

WARNING



FALLING LOAD HAZARD!

Incorrect lifting methods and faulty lifting equipment, can cause lifting equipment to snap under load, which could cause death or severe injury.

Use appropriate transport devices, lifting equipment and lifting tackle to move heavy assemblies or components.

Always observe the safety instructions and information.

For any work on the motor, observe the instructions of the relevant motor manufacturer.

For dismantling and reassembly observe the exploded views and the general assembly drawing.

In case of damage you can always contact our service staff.



NOTE: Before dismantling the pump make sure that it has stopped. Empty the pump of liquid before it is dismantled from the piping system. If the pump has been pumping dangerous liquids you are to be aware of this and take the necessary safety measures.

If the pump has been pumping hot liquids, take great care that it is drained before it is removed from the piping system.



NOTE: All maintenance, service and installation work can be carried out by DESMI or authorized workshops. Contact our sales staff to discuss your requirement.



NOTE: After a prolonged period of operation the individual components may be hard to pull off the shaft. If this is the case, use a brand name penetrating agent and/or – if possible – an appropriate puller.

If regular maintenance log off the pump/motor cannot be demonstrated, the manufacturer's warranty obligations shall become void.

Preparing the pump set

1. De-energise the pump set and secure it against unintentional start-up.
2. Reduce pressure in the piping by opening a consumer installation.
3. Disconnect and remove all auxiliary pipework.

Draining the pump

When the piping system has been drained, note that there is still liquid in the pump. Remove the liquid by dismantling the pipe plug (3) at the bottom of the pump.

Dismounting the complete pump set



NOTE: The pump casing can remain installed in the piping for further dismantling.

The notes and steps stated in have been observed/carried out.

1. Disconnect the discharge and suction nozzle from the piping.
2. Depending on the pump/motor size, unscrew the bolts that fix the support foot and/or motor foot to the foundation.

3. Remove the complete pump set from the piping.

Remove the motor

WARNING



CRUSHING HAZARD!

Removing the motor could cause it tipping over leading to death or severe injury.

Suspend or support the motor to prevent it from tipping over.

Note: On NSL /-12 design pumps the motor, motor bracket, rear cover and shaft with impeller shall be lifted away from the pump casing as one assembled unit !

Lifting eyes must be of the type shown and shoulder must rest on the electric motor – if required use a spring washer if the lifting eye cannot be tightened and placed in the correct orientation as shown below.

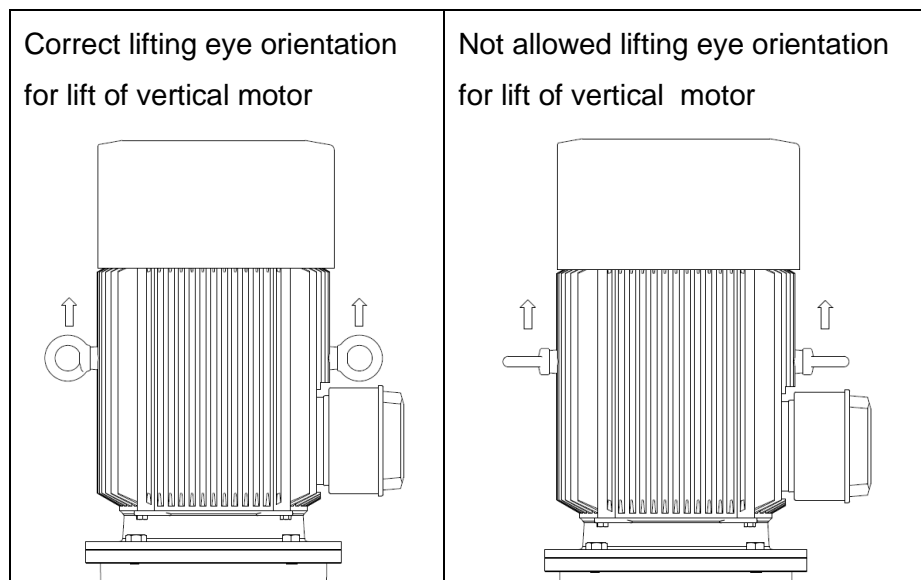

Remove the back pull-out unit

WARNING



CRUSHING HAZARD!

Removing the back pull-out unit could cause it tipping over leading to death or severe injury.

Suspend or support the back pull-out unit at the pump end.

9.1. 02 and 12 combinations

9.1.1. Access to impeller

The numbers in brackets refer to the position numbers on the assembly drawing.

Ø215/265-02 combination

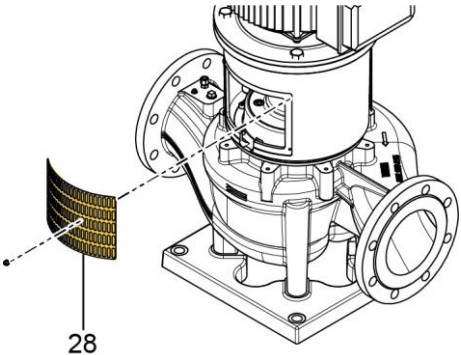
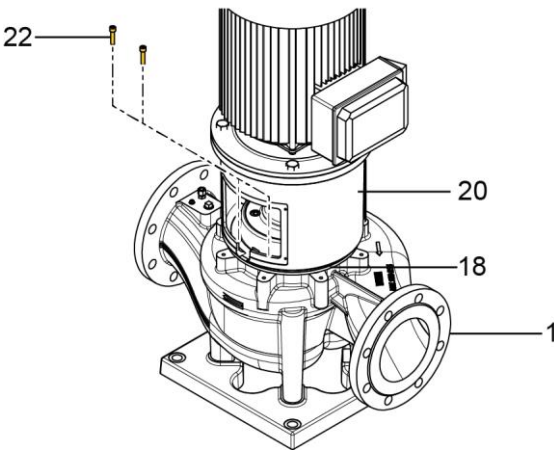
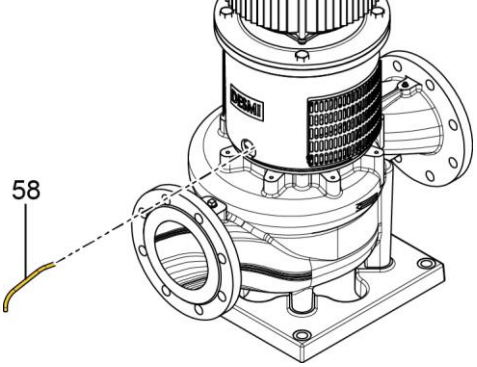
<p>1. Remove guards (28).</p>	 <p>A technical drawing of a pump set with a guard (28) being removed. The guard is a cylindrical mesh structure. A dashed line points from the number 28 to the guard.</p>
<p>2. Remove Allen screws (22) which hold the rear cover (18) and the motor bracket (20) to the pump casing (1).</p>	 <p>A technical drawing of a pump set with two Allen screws (22) being removed. The screws are shown being pulled out from the rear cover (18) and motor bracket (20). The pump casing (1) is also labeled. Dashed lines connect the numbers to the respective parts.</p>
<p>3. Dismantle pipe (58).</p>	 <p>A technical drawing of a pump set with a pipe (58) being dismantled. The pipe is shown being pulled away from the pump casing. A dashed line connects the number 58 to the pipe.</p>

4. Remove motor bracket and motor. The rear cover with shaft and impeller can now be lifted up allowing inspection of the impeller.

Ø215/265-12 combination

1. Remove guards (28).

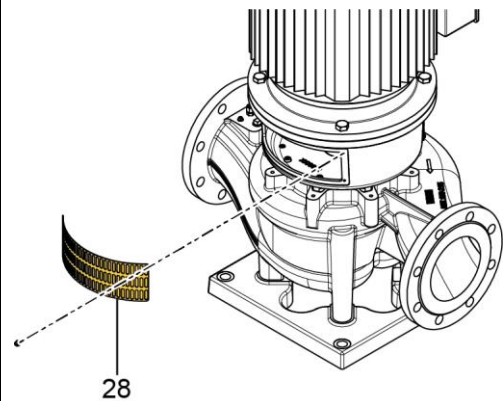

2. Remove Allen screws (22) which hold the motor bracket (20) to the pump casing (1) (stainless steel pumps have separate rear cover (18) and motor bracket (20), and use Allen screw (40) to connect).

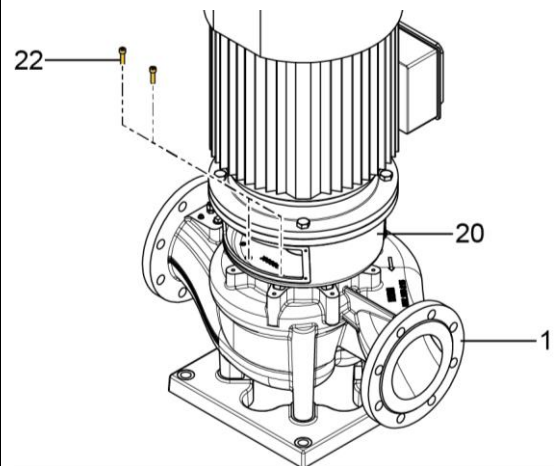

3. Dismantle pipe (58). The top piece can now be lifted up allowing inspection of the impeller.

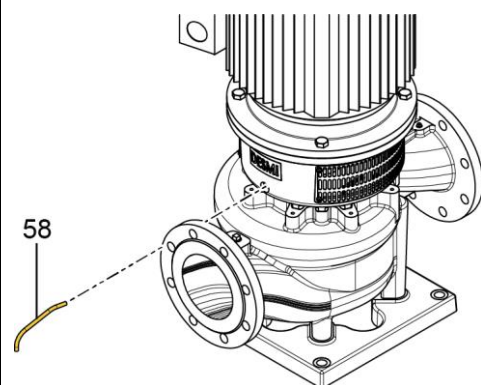

Ø330/415/418/465/525-02 combination

1. Remove guards (28).

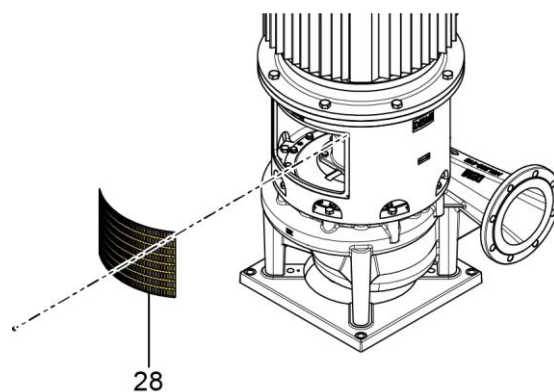

2. Remove set screws (64) which hold the motor bracket (20) to the pump casing (1).

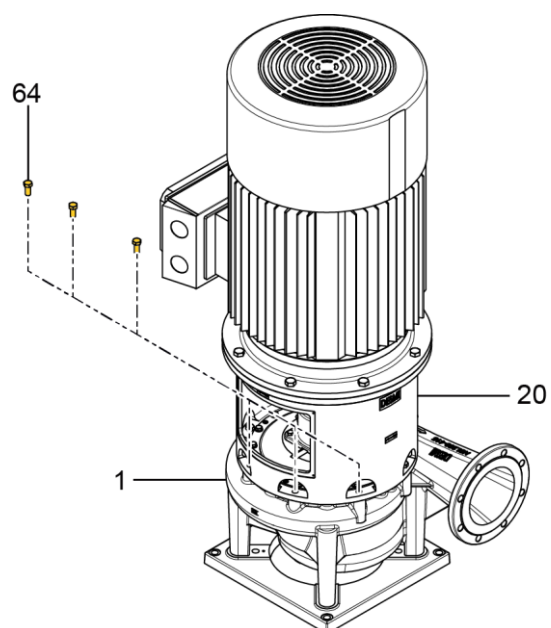

3. Dismantle pipe (58).

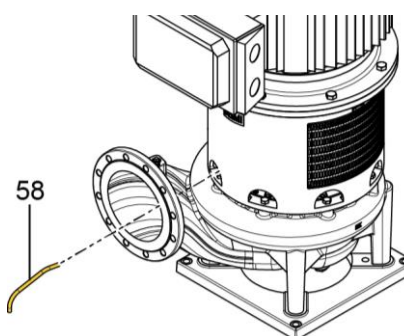

4. Remove motor bracket and motor.

5. Remove set screws (22) with washers (23), which hold the rear cover (18) to the pump casing (1).

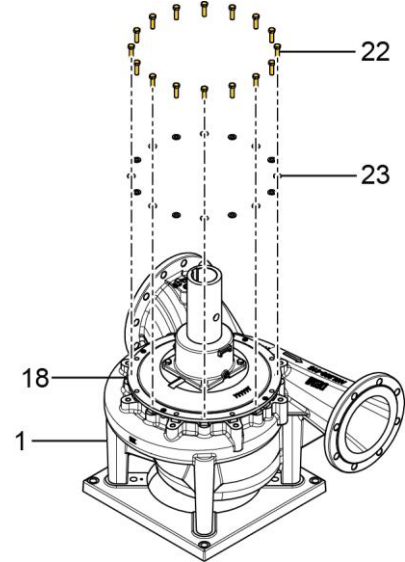

6. Loosen the rear cover from the pump casing by means of the pointed screws (86). The rear cover with shaft and impeller can now be lifted up allowing inspection of the impeller.

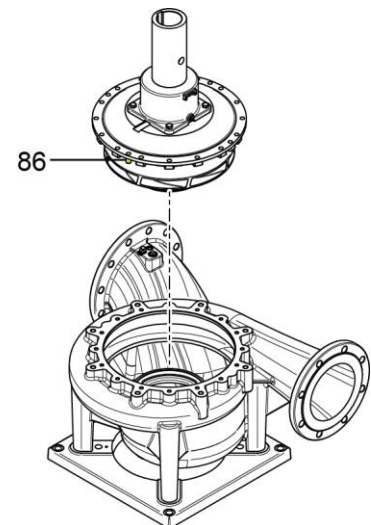

Ø330/415/418/465/525-12 combination

1. Remove guards (28).

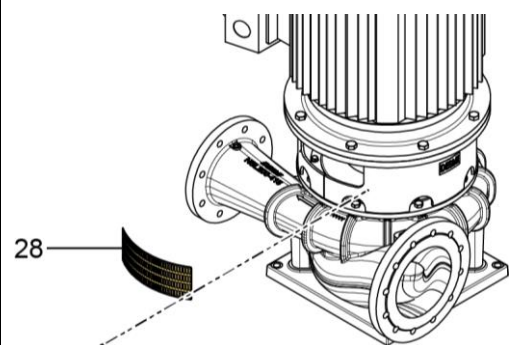

2. Remove set screws (64) which hold the motor bracket (20) to the pump casing (1).

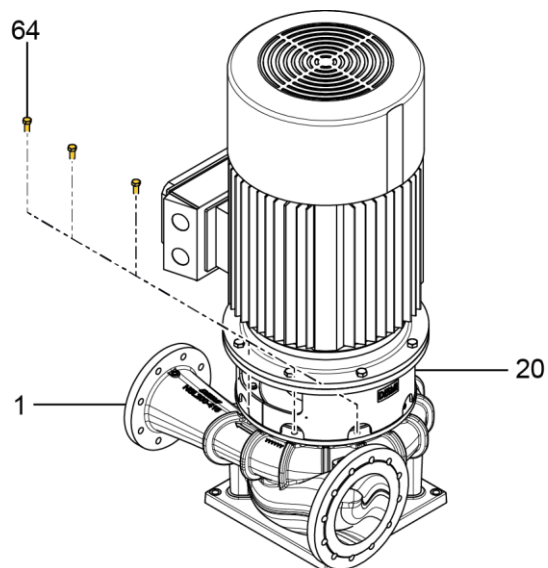

3. Dismantle pipe (58).

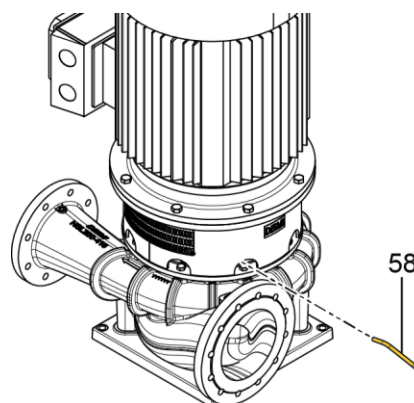

4. Remove set screws (22) with washers (23), which hold the rear cover (18) to the pump casing.

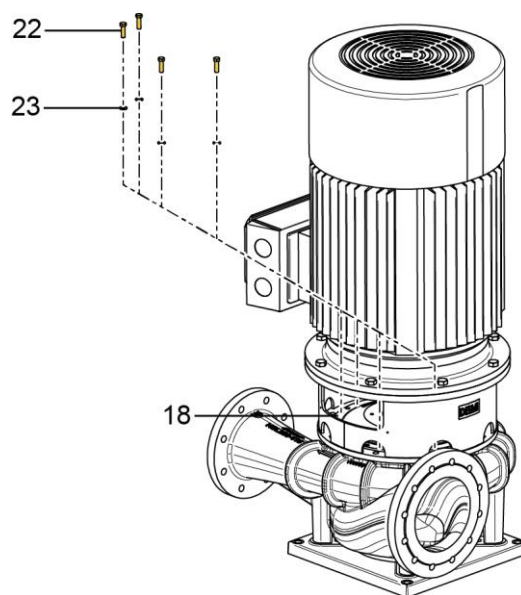

5. Loosen the rear cover from the pump casing by means of the pointed screws (86). The motor and motor bracket with rear cover and shaft with impeller can now be lifted up allowing inspection of the impeller.

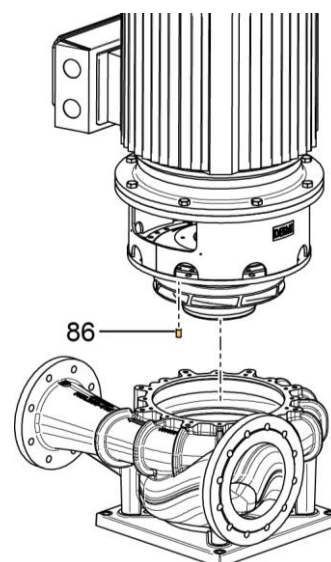

9.1.2. Dismantling shaft seal

Ø215/265-02 combination

1. Pull the rear cover off the motor bracket, by which the coupling (19) is pulled off the motor shaft.

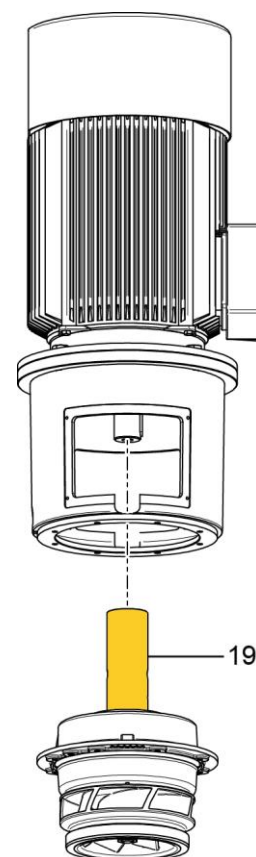

- Remove nut (6). Pull off the impeller (5) and remove sunk key (9).

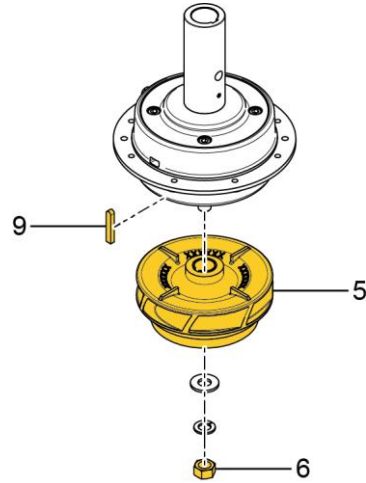

- Remove Allen screws (16), which hold the bearing cover (15) to the rear cover, pull rear cover and bearing cover apart, by which shaft seal (10) and water deflector (11) are pulled off the shaft.

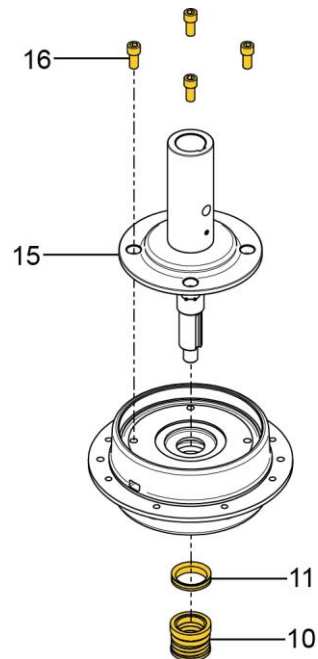

Ø215/265-12 combination

- Remove nut (6). Pull off the impeller (5), and remove sunk key (9).

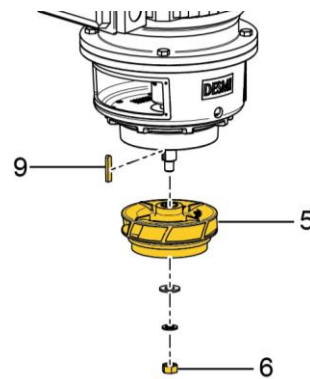

2. Remove set screws (71) and pull motor bracket and electric motor with shaft (17) apart, by which the shaft seal (10) is pulled off the shaft.

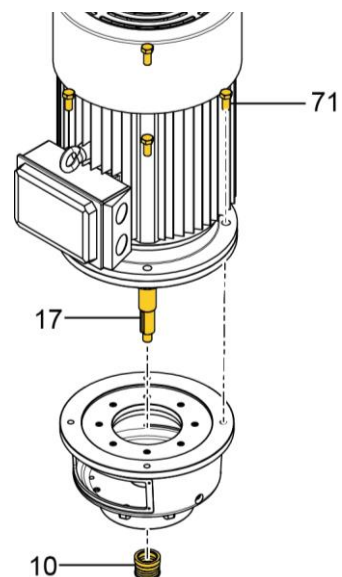
**Ø330/415/418/465/525-02 combination**

1. Remove set screw (6). Pull off the impeller (5), and remove sunk key (9).

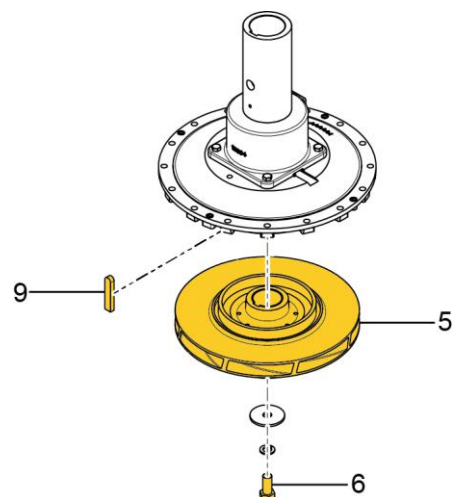

- Remove set screws (16), which hold the bearing cover (15) to the rear cover, pull rear cover and bearing cover apart, by which the shaft seal (10) is pulled off the shaft.

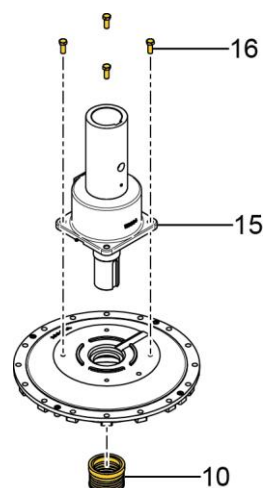

Ø330/415/418/465/525-12 combination

- Remove set screw (6). Pull off the impeller (5), and remove sunk key (9).

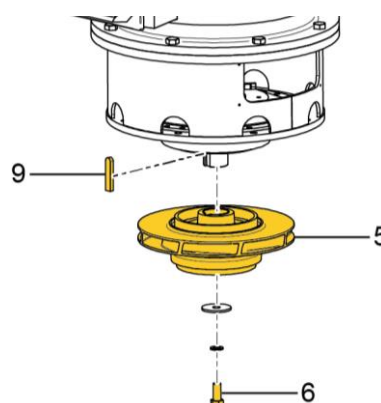

- Pull rear cover out of motor bracket, by which the shaft seal (10) is pulled off the shaft.

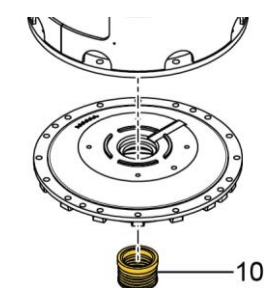

9.1.3. Dismantling seat

1. Press out the seat from behind the rear cover or motor bracket ($\varnothing 215/265$ in 12 combination).

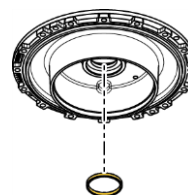

9.1.4. Dismantling bearing (only 02 combination)

1. Before dismantling bearing, remove ring lock (12). Pull the shaft/coupling out of the bearing cover and press the bearing out of the bearing cover.

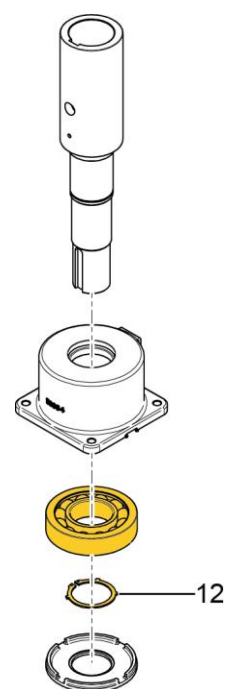

9.1.5. Inspection

When the pump has been dismantled, check the following parts for wear and damage:

- Sealing ring/impeller: Max. clearance 0.4-0.5 mm measured in radius.
- Shaft seal/rear cover: Check the seat for flatness and cracks.

Check the rubber parts for elasticity.

- Bearings: Replace in case of wear and noise.

9.1.6. Dismantling coupling (02 combination) / shaft (12 combination)

It is not necessary to remove the coupling in the 02 combination or the shaft in the 12 combination during normal maintenance. However, in the 12 combination the shaft must be removed when the lower bearing in the electric motor is replaced.

02 combination:

1. Dismantle the coupling by removing the pointed screw (73) and pull off the coupling. The coupling might be heated to help dismantling.

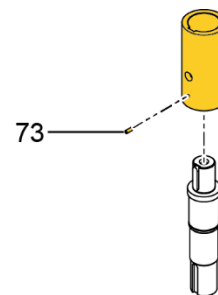

NOTE: If the coupling is removed on the assembled pump, take care that the bearing is not damaged by pulling too hard on the coupling. If the coupling is removed after dismantling the pump, fix the shaft at the thread at the opposite shaft end, while the coupling is pulled off.

12 combination :

1. Remove pointed screws (73). Pull off the shaft. The coupling might be heated to facilitate dismantling.

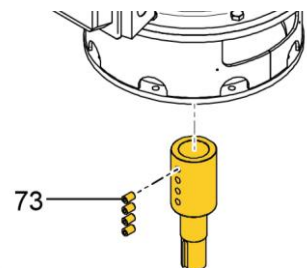

9.2. 13 and 14 combinations

9.2.1. Access to impeller

The numbers in brackets refer to the position numbers on the assembly drawing.

Ø215/265

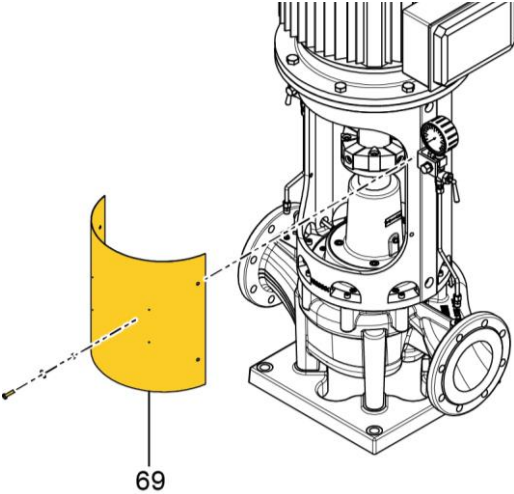
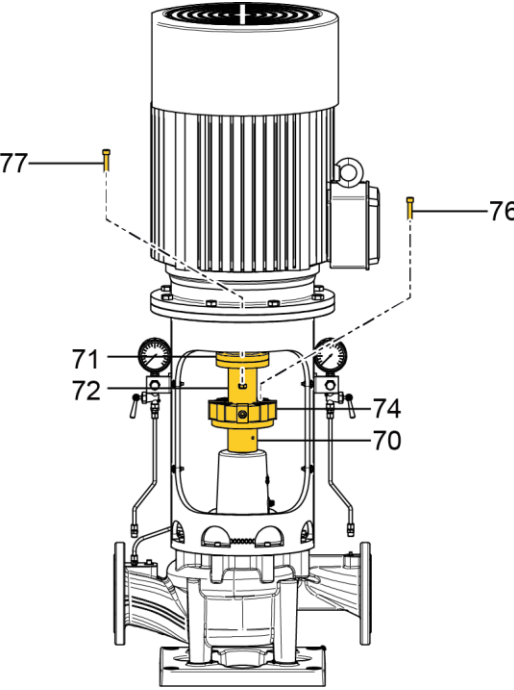
<p>1. Dismantle guard(69).</p>	
<p>2. Remove Allen screws (77) between coupling part motor (71) and spacer (72) and the screws (76), which hold the flexible coupling (74) to the coupling part pump (70). It is not necessary to remove the screws (also 76) which hold the flexible coupling to the spacer. After a vertical pull downwards take out the spacer (72).</p>	

3. Loosen the pointed screw (73) and pull the coupling part pump (70) off the shaft.

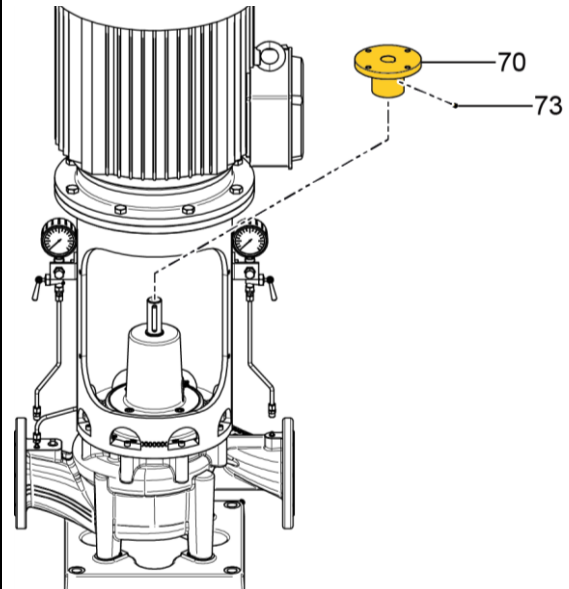

4. Dismantle the pipe (58).

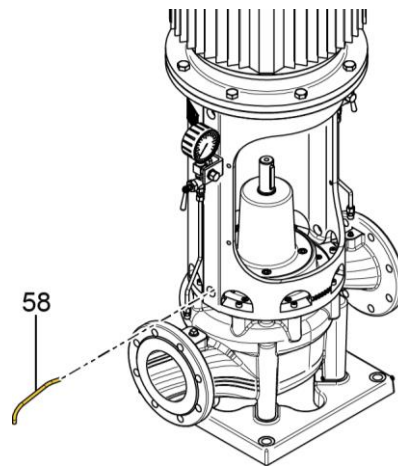

5. Remove Allen screws (22) which hold the rear cover (20) to the pump casing. Remove the rear cover from the pump casing by means of the pointed screws (86). The bearing housing with shaft and impeller can now be lifted up from the pump as a unit, and the impeller can be inspected.

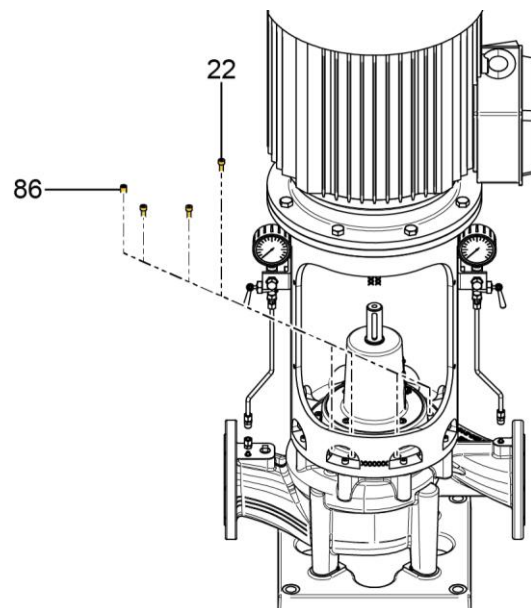

Ø330/415/418/465/525

1. Dismantle guard(69).

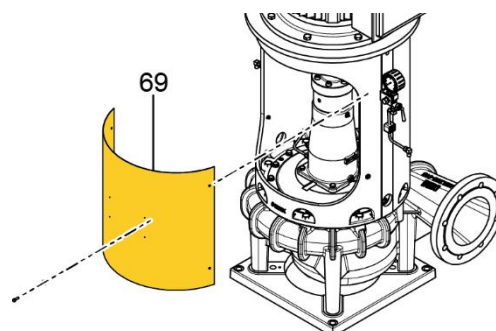

2. Remove Allen screws (76) at each end of the coupling and remove the spacer (72).

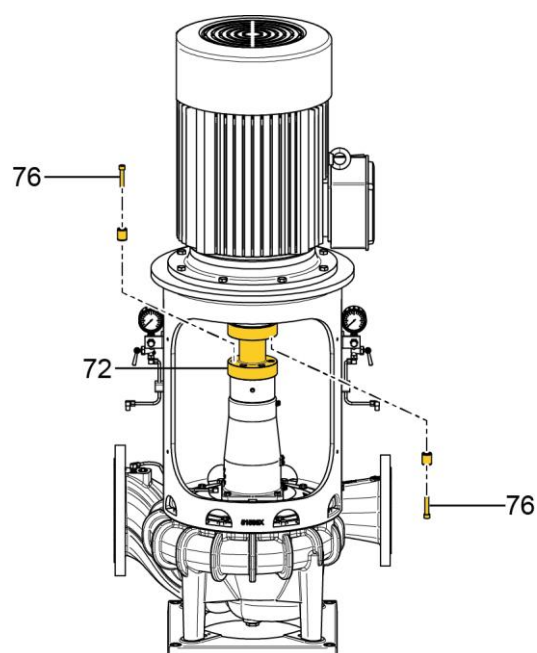

3. Loosen the pointed screw (73) and pull the coupling part pump (70) off the shaft.

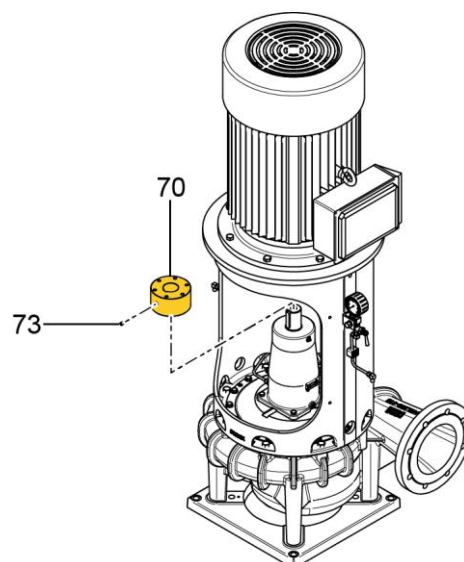

4. Dismantle the pipe (58).

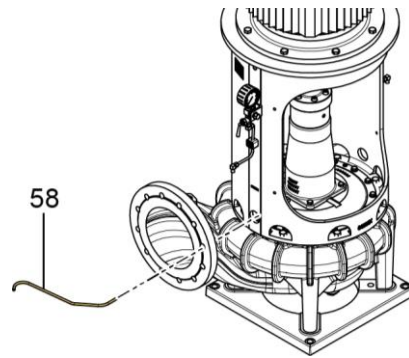

5. Remove set screws (22) with washers (23) which hold the rear cover to the pump casing. Remove the rear cover from the pump casing by means of the pointed screws (86). The rear cover and the bearing housing with shaft and impeller can now be lifted up from the pump as a unit, and the impeller can be inspected.

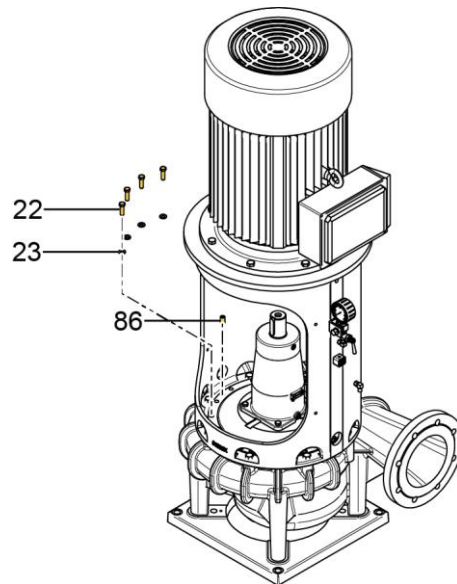

9.2.2. Dismantling shaft seal

Ø215/265

1. Remove nut (6). Pull off the impeller and remove sunk key (9).

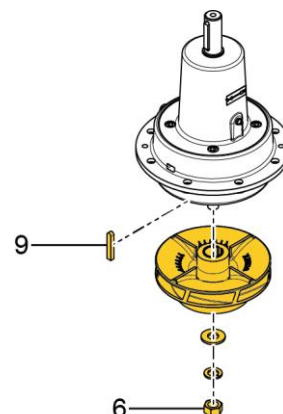

- Remove Allen screws (19), which hold the bearing housing to the rear cover, pull rear cover and bearing housing apart, by which the shaft seal (10) and water deflector (11) are pulled off the shaft.

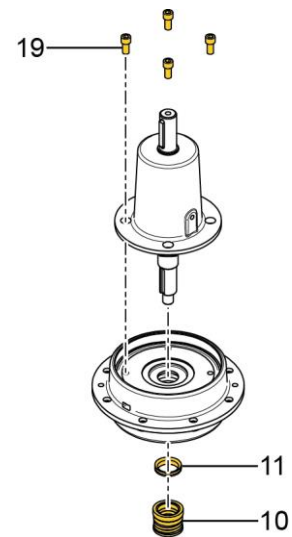

Ø330/415/418/465/525

- Remove set screw (6). Pull off the impeller and remove sunk key (9).

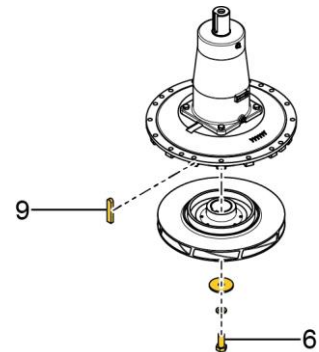

- Remove set screws (19), which hold the bearing housing to the rear cover, pull rear cover and bearing housing apart, by which the shaft seal (10) is pulled off the shaft.

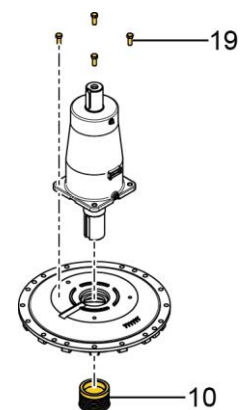

9.2.3. Dismantling seat

1. Press out the seat from behind the rear cover.

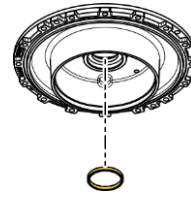

9.2.4. Dismantling shaft with bearings

1. Before dismantling the shaft with bearings, remove the sunk key (16). The shaft can now be pulled out of the bearing housing allowing inspection of the bearings.

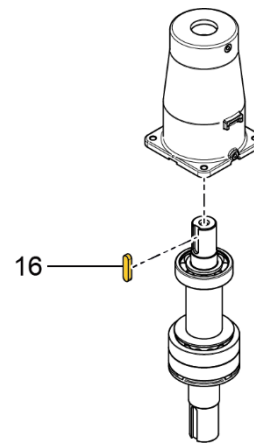

9.2.5. Inspection

When the pump has been dismantled, check the following parts for wear and damage:

- Sealing rings/impeller: Max. clearance 0.4-0.5 mm measured in radius.
- Shaft seal/rear cover: Check the seat for flatness and cracks.

Check the rubber parts for elasticity.

- Bearings: Replace in case of wear and noise.

10. ASSEMBLING THE PUMP SET

CAUTION



RISK OF PROPERTY DAMAGE!

The type of accessories used during assembling work including oil and grease shall meet the the requirement from application, food-approved if required.

10.1. Tightening Torques

Part. No.		Thread Size (mm)	Tightening Torque (Nm)	
NSL-02/12	NSL-13/14		Pump Casing/Rear Cover in GG20/Rg5 material	Pump Casing/Rear Cover in GGG40/NiAlBz/SS material
64		M8	8	16
		M12	27	54
		M16	65	130
22		M8	8	16
		M12	27	54
		M16	65	130
16	19	M12	27	54
		M16	65	130
6		M16	65	
		M20	130	
		M24	220	
71	60	M12	54	
		M16	130	
		M20	240	
		M24	400	

10.2. 12 combination

10.2.1. Fitting sealing rings

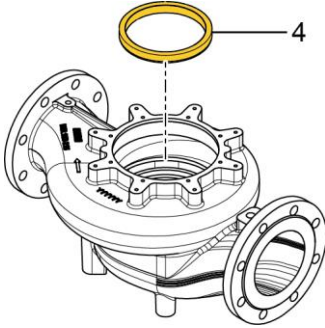
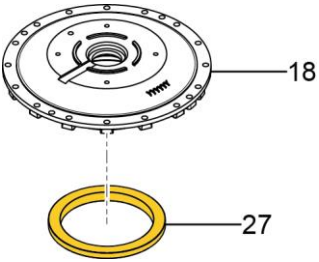
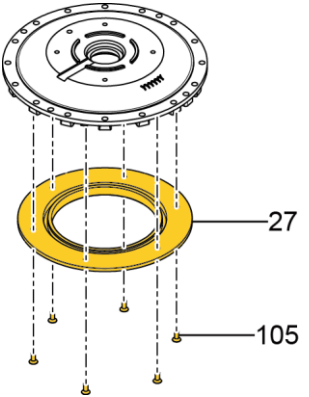
<p>1. When fitted, the sealing ring (4) is to bear against the shoulder of the pump casing.</p>	
<p>For Ø330/415/418/525, when fitted the sealing ring (27) is to bear against the shoulder of the rear cover (18).</p>	
<p>For ø418, secure the sealing ring (27) with counter sunk screws (105).</p>	

For NSL350-525, Secure the sealing ring (27) and Guard plate (38) with Counter sunk screw (39).

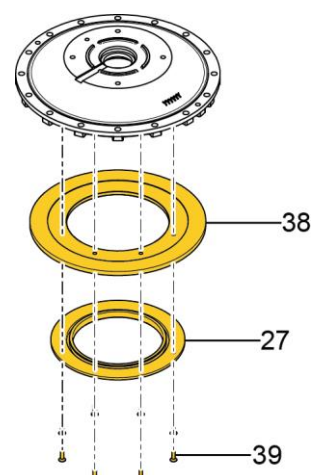

10.2.2. Fitting shaft seal

For pumps with balanced shaft seal type ELK (=“-L” included in pump code on name plate) please read appendix A.

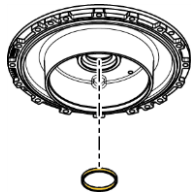
<p>1. Clean the recess in the rear cover or the motor bracket ($\varnothing 215/265$).</p>	
<p>2. Remove the protective coating of the seat without scratching the lapped surface and lubricate the outer rubber L-ring of the seat with a thin layer of silicone grease. Use a brush and ensure that no silicone grease ends up at the slide surface.</p>	
<p>3. Press the seat into place with the fingers and check that all parts are correctly imbedded.</p>	



NOTE: If it is necessary to use tools for assembling, then protect the sliding surface of the seat to prevent it from being scratched or cut. Lubricate inner surface of the slide ring rubber bellows with a thin layer of silicone grease (ensure that no silicone grease ends up at the slide surfaces) and push it over the shaft. The use of a conical fitting bush as shown on the assembly drawing is recommended to avoid that the rubber bellows is cut.



NOTE: Push the slide ring over the shaft with the hand. If the rubber bellows is tight, use a fitting tool and take care that the slide ring is not damaged. If the carbon ring is not fixed, it is important to check that it is fitted correctly, i.e. the chamfered/lapped side is to face the seat. The carbon ring can be held by a little grease.



NOTE: When using silicone grease on the shaft, the bellows will settle and seat in about 15 minutes, and until then tightness should not be expected. After start, check by viewing the leak hole that there are no leaks.

10.2.3. Fitting impeller

1. Mount the pump shaft on the motor shaft and check if run-out is OK within tolerance 0.07 mm.

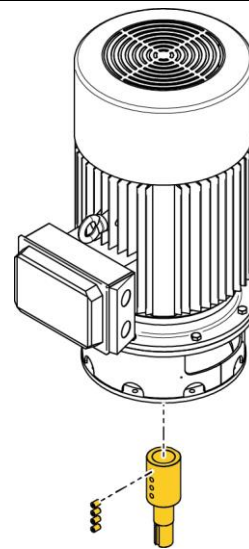

2. For Ø215/265, mount the motor bracket and shaft seal (10) to the electric motor with shaft.

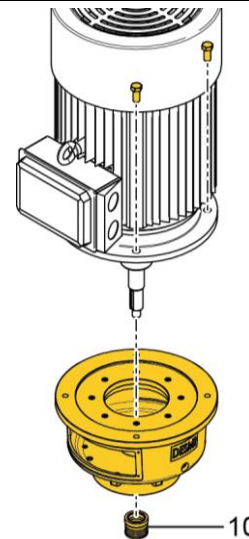

3. For Ø330/415/418/465/525, fix the rear cover to the motor bracket mounted with electric motor. Assemble the shaft seal (10) .

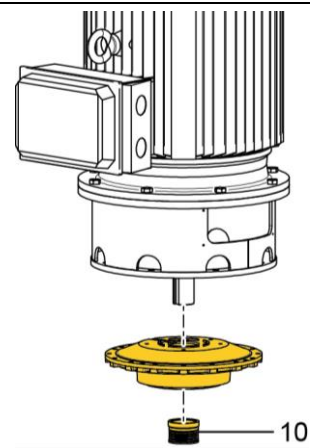

4. Fit the sunk key in the shaft and lead the impeller towards the shoulder of the shaft. Secure the impeller with washers (7 and 8) and a nut (Ø215/265/418) or a set screw (Ø330/415/465/525).

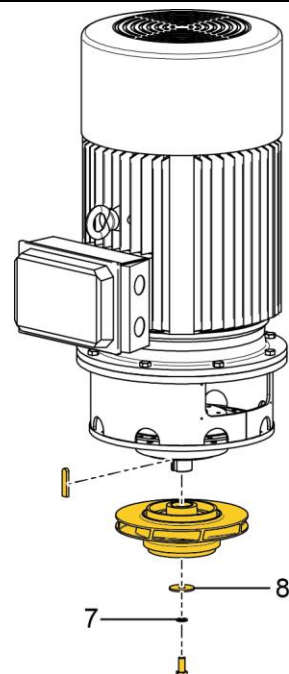

NOTE: Take care that the ring at the end of the shaft seal spring locates in the recess of the impeller.

10.2.4. Fitting rear cover or motor bracket

1. Place the O-ring (21) between pump casing and rear cover (or motor bracket in $\varnothing 215/265$) in the O-ring groove and hold it with a little grease.

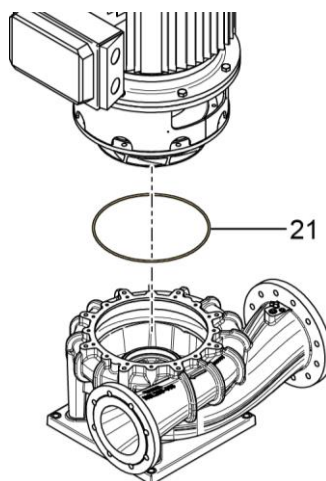

2. Screw the pointed screws (86) back into the rear cover.

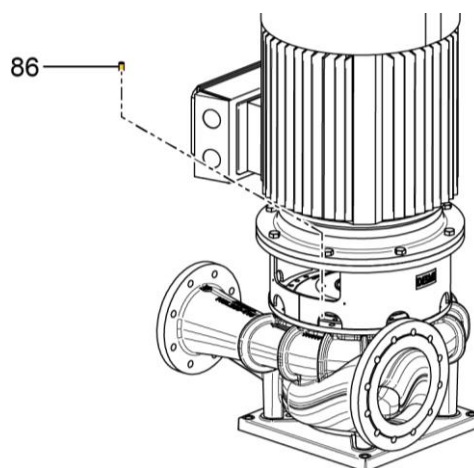

3. Fit and fasten rear cover and/or motor bracket, mounted with the electric motor, in the pump casing.

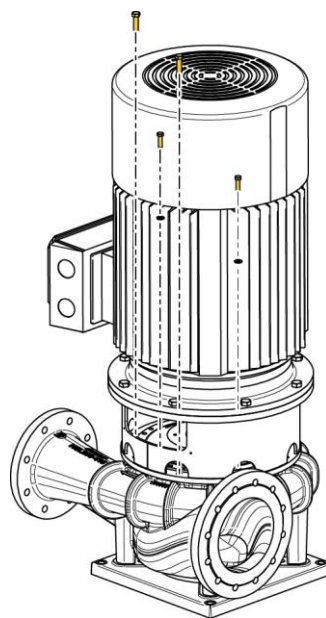

4. Fit pipe (58).

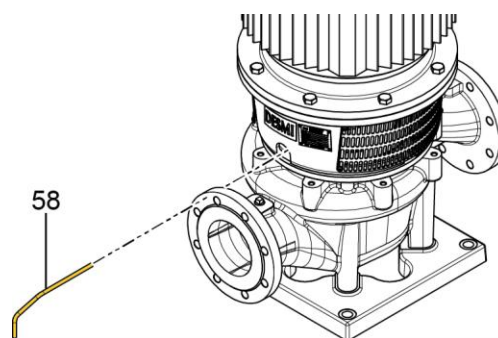

NOTE: When placing the O-ring, check the material of the O-ring first. As standard the material is nitrile, but it might be EPDM which will be damaged by mineral grease. Use soft soap or silicone grease for EPDM.

10.2.5. Shaft

When the pump has been assembled, check that the shaft rotates freely. In case the shaft has been dismantled, tap the shaft towards the shaft end of the electric motor by means of a plastic hammer, and fasten the pointed screws (first the middle screw) according to the below table. Check that the wobble, measured as close to the shaft end as possible, is within the limits indicated in the table.

Motor size	Dimension Pointed screws	Torque Pointed screws	Max. wobble
100/112	M6	10 Nm	70 µm
132	M8	24 Nm	70 µm
160	M10	40 Nm	70 µm
180	M12	55 Nm	70 µm
200	M12	75 Nm	70 µm
225	M16	160 Nm	70 µm
250	M16	160 Nm	70 µm
280	M16	160 Nm	70 µm
315	M16	160 Nm	70 µm
315 / 355	M20	320 Nm	70 µm

10.3. 02, 13 and 14 combinations

10.3.1. Fitting sealing rings

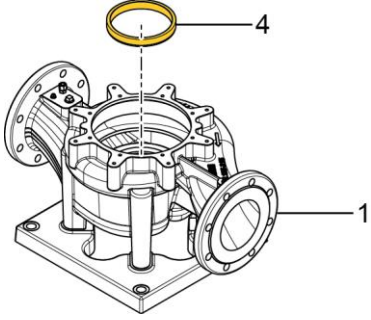
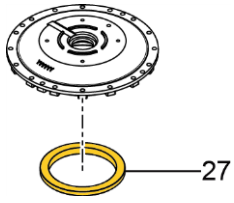
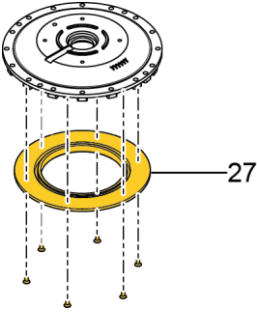
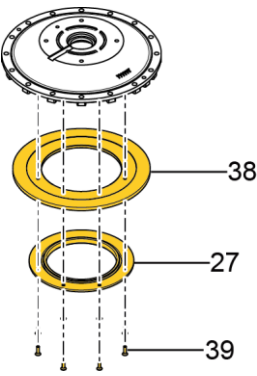
<p>1. When fitted, the sealing ring (4) in the pump casing (1) is to bear against the shoulder of the pump casing.</p>	
<p>For Ø330/415/418/465/525, when fitted, the sealing ring (27) in the rear cover is to bear against the shoulder of the rear cover.</p>	
<p>For Ø418, secure the sealing ring (27) with counter sunk screws.</p>	
<p>For NSL350-525, secure the sealing ring (27) and Guard plate (38) with Counter sunk screw (39).</p>	

10.3.2. Fitting bearings or shaft with bearings

In 02 combination:

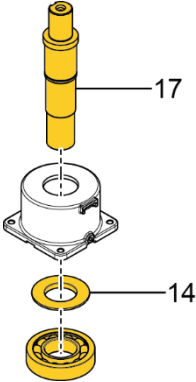
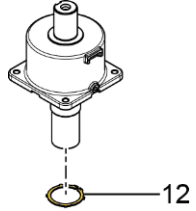
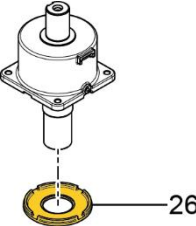
<p>1. Place the support disc (14) (grease valve ring in $\varnothing 330/415/418/525$ with angular ball bearings) in the bearing cover and press the bearing into place in the bearing cover. Lead the shaft (17) through the bearing cover, support disc and bearing, and press the bearing into place up against the support disc.</p>	
<p>2. Fit ring lock (12).</p>	
<p>3. Fit cover under bearing (26). (Only for $\varnothing 330/415/418/465/525$)</p> <p>If shim(s) are mounted between Pos. 26 and bearing then also mount shim(s) when bearings are replaced.</p> <p>DESMI spare part numbers for 0.1 mm thick shims:</p> <p>705057 (SHIM $\varnothing 110/140$)</p> <p>707214 (SHIM $\varnothing 130/160$)</p> <p>722876 (SHIM $\varnothing 160/190$)</p>	

In 13 and 14 combinations:

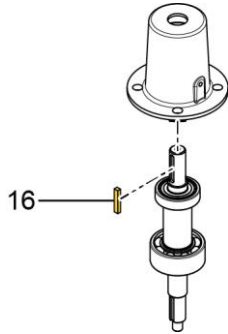
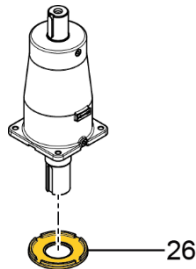
<p>1. Lead shaft with bearings into the bearing housing. Fit sunk key (16).</p>	
<p>2. Fit cover under bearing (26). (Only for Ø330/415/418/465/525)</p> <p>If shim(s) are mounted between Pos. 26 and bearing then also mount shim(s) when bearings are replaced.</p> <p>DESMI spare part numbers for 0.1 mm thick shims:</p> <p>705057 (SHIM Ø110/140)</p> <p>707214 (SHIM Ø130/160)</p> <p>722876 (SHIM Ø160/190)</p>	

For pumps with Lip seal in cover under bearing please read Appendix B.

10.3.3. Fitting water deflector

Ø215/265

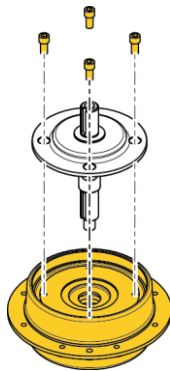
<p>1. Assemble bearing cover and rear cover.</p>	
--	---

2. Lead the water deflector (11) over the shaft until it touches the rear cover and then further 1-1.5 mm into the rear cover. Do not fasten bearing cover and electric motor until the motor has been mounted and the shaft can rotate freely without noise.

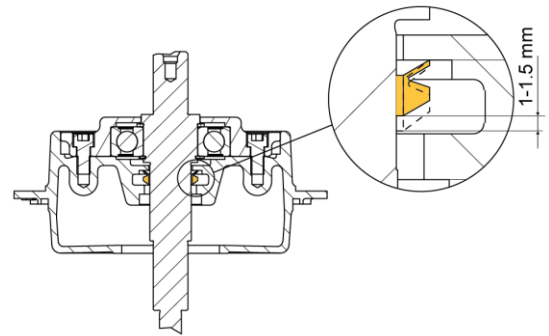

Ø330/415/418/465/525

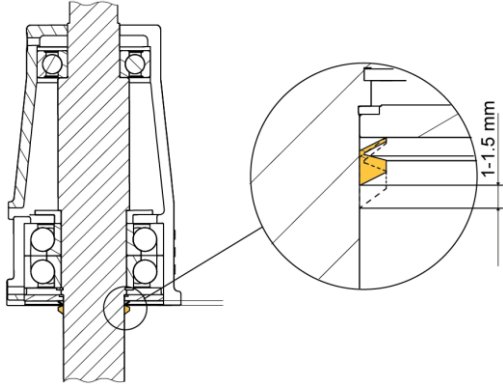
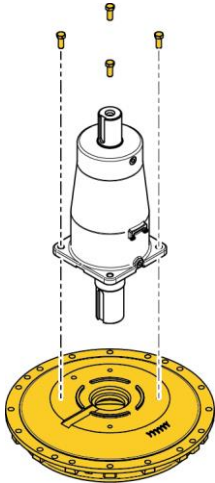
<p>1. Lead the water deflector (11) over the shaft until it touches the cover under bearing (26) and then further 1-1.5 mm towards the cover under bearing.</p>	
<p>2. Assemble bearing cover and rear cover. Do not fasten bearing cover and electric motor until the motor has been mounted and the shaft can rotate freely without.</p>	

10.3.4. Fitting shaft seal

For pumps with balanced shaft seal type ELK (= "L" included in pump code on name plate) please read appendix A.

<p>1. Clean the recess in the rear cover.</p>	
<p>2. Remove the protective coating of the seat without scratching the lapped surface and lubricate the outer rubber L-ring on the seat with a thin layer of silicone grease. Use a brush and ensure that no silicone grease ends up at the slide surface.</p>	

3. Press the seat into place with the fingers and check that all parts are correctly imbedded.

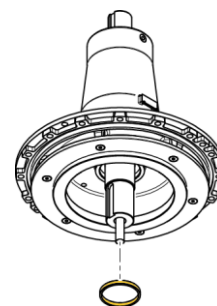

NOTE: If it is necessary to use tools for assembling, then protect the sliding surface of the seat to prevent it from being scratched or cut. Lubricate the inner surface of the slide ring rubber bellows with a thin layer of silicone grease (ensure that no silicone grease ends up at the slide surfaces) and push it over the shaft. The use of a conical fitting bush as shown on the assembly drawing is recommended to avoid that the rubber bellows is cut.



NOTE: Push the slide ring over the shaft with the hand. If the rubber bellows is tight, use a fitting tool and take care that the slide ring is not damaged. If the carbon ring is not fixed, it is important to check that it is fitted correctly, i.e. the chamfered/lapped side is to face the seat. The carbon ring can be held by a little grease.



NOTE: When using silicone grease on the shaft, the bellows will settle and seat in abt. 15 minutes, and until then tightness should not be expected. After start, check by viewing the leak hole that there are no leaks.

10.3.5. Fitting impeller

Ø215/265

1. Fit the sunk key in the shaft and lead the impeller towards the shoulder of the shaft. Secure the impeller with washers (7 and 8) and a nut.

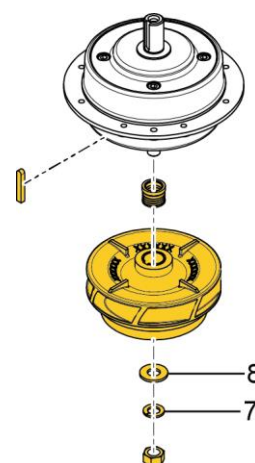

Ø330/415/418/465/525

1. Fit the sunk key in the shaft and lead the impeller towards the shoulder of the shaft. Secure the impeller with washers (7 and 8) and a set screw.

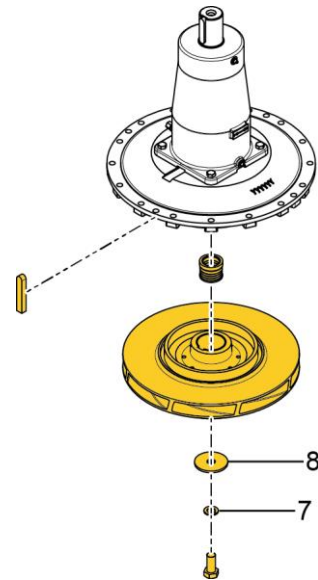

NOTE: Take care that the ring at the end of the shaft seal spring locates in the recess of the impeller.

10.3.6. Fitting bearing housing and rear cover

1. Place the O-ring (21) between pump casing and rear cover on the rear cover where it can be held with a little grease.

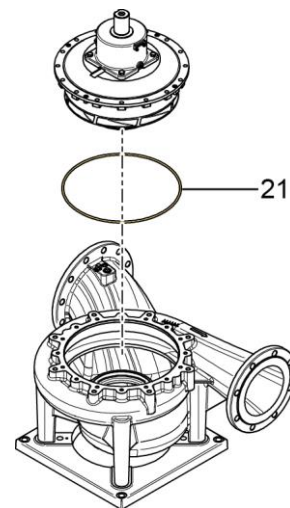

2. Screw the pointed screws (86) back into the rear cover.

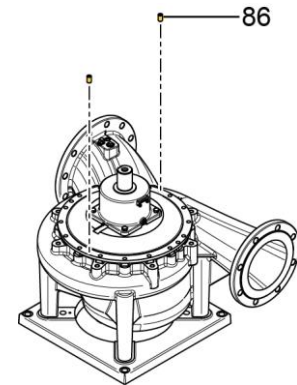

3. Fit and fasten bearing housing and rear cover in the pump casing.

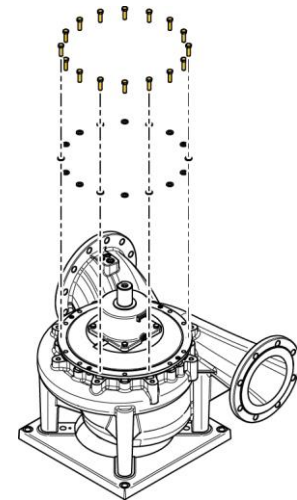

NOTE: When placing the O-ring, check the material of the O-ring first. As standard the material is nitrile, but it might be EPDM which will be damaged by mineral grease. Use soft soap or silicone grease for EPDM.

10.3.7. Shaft

When the pump has been assembled, check that the shaft rotates freely.

10.3.8. Fitting coupling

In 02 combination:

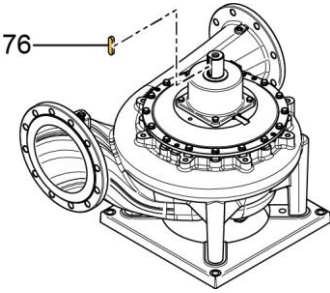
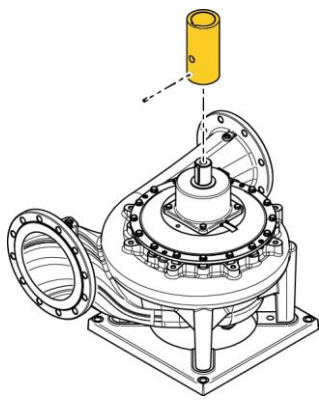
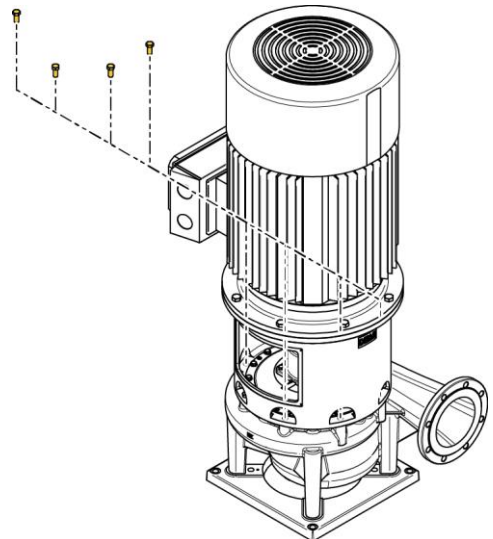
<p>1. Fit sunk key (76).</p>	
<p>2. When the coupling bears against the shoulder of the pump shaft, fit the pointed screw.</p> <p>If the vertical gap (paint thickness not considered) between bearing bracket and coupling is less than 1 mm the pump ball bearing(s) shall most likely be replaced.</p> <p>Hint: After bearing replacement (or on a new pump) record the vertical gap as reference value for later inspections.</p>	
<p>3. Fit and fasten the motor bracket mounted with the electric motor to the pump casing.</p>	

4. Fit pipe (58).

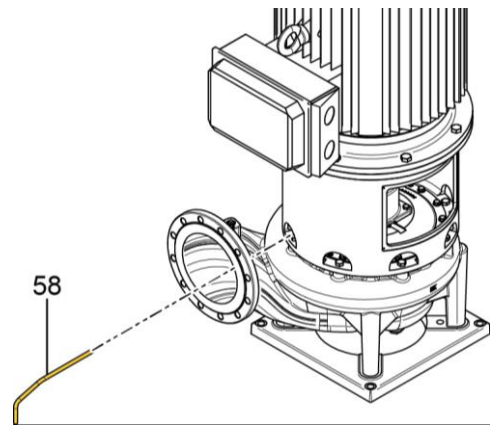

NOTE: If the coupling is fitted on the assembled pump, take care that you do not damage the bearing by pressing the coupling too hard. The coupling might be heated to facilitate the fitting. If the coupling is fitted before assembling the pump, the shaft must be supported at the opposite shaft end while the coupling is pressed into place.

In 13 and 14 combinations:

Ø215/265

1. Fit the flexible coupling (74) to the spacer (72) by means of the Allen screws (76) which are tightened up with torque according to the table below.

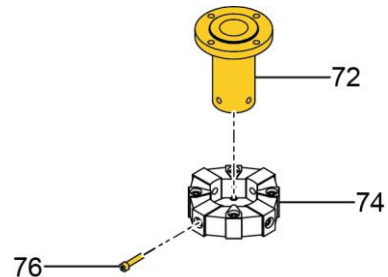

2. Secure the coupling part pump (70) to the shaft by means of the pointed screw (73).

If the vertical gap (paint thickness not considered) between bearing bracket and coupling is less than 1 mm the pump ball bearing(s) shall most likely be replaced.

Hint: After bearing replacement (or on a new pump) record the vertical gap as reference value for later inspections.

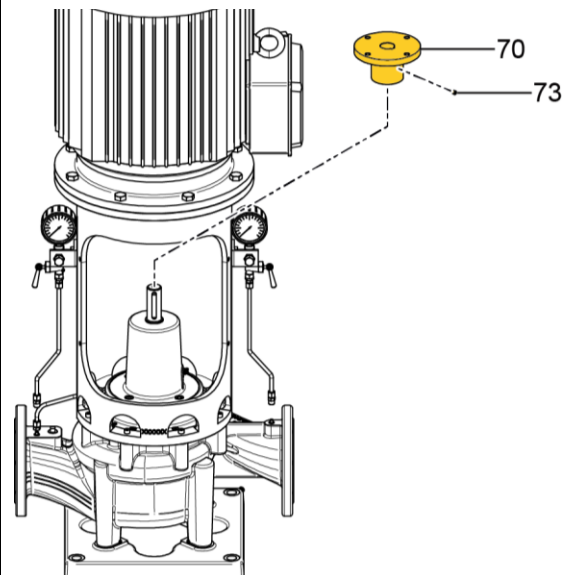

3. Fix the spacer with the flexible coupling to the coupling part motor (71) by means of the Allen screws (77) and lock nuts (79), also with torque according to the table below. In order to secure the bolt connection fit a new lock nut or secure with a locking means.

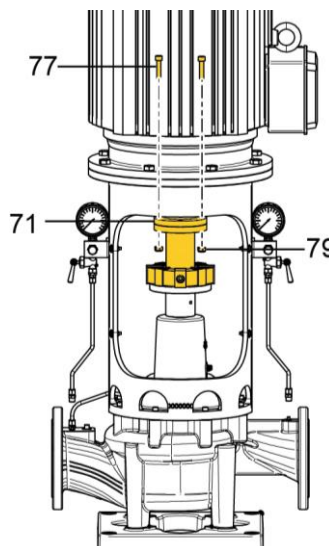

4. Fit the flexible coupling to the coupling part pump by means of the Allen screws (76) which are to be greased a little under the bolt head and tightened with the torque stated.

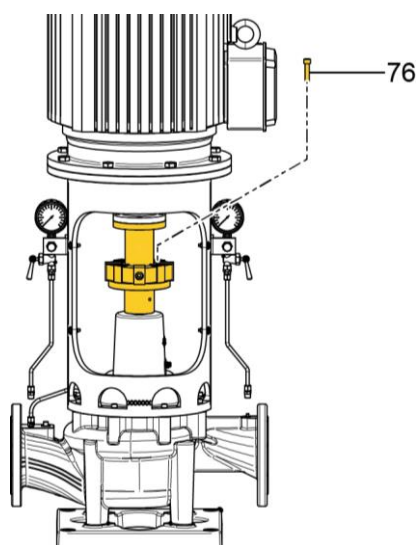

5. Fit pipe (58).

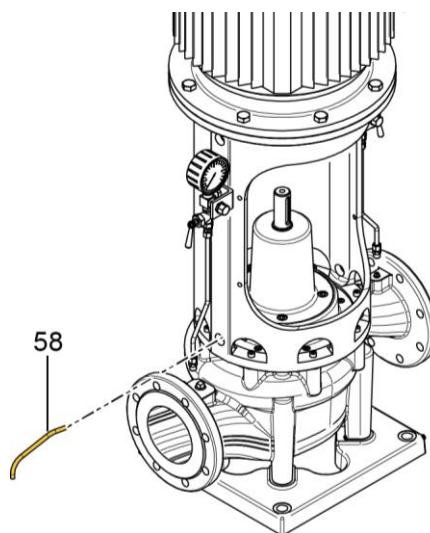



NOTE: Check that the aluminum insert in the rubber part does not rotate during tightening as it may damage the coupling. To prevent this, apply a little grease to the bolts under the bolt head. The Allen screws (76) can be used again and up to 3 times before they are to be replaced by new original bolts to secure the locking function. Do not use Loctite as it will damage the rubber element.



NOTE: Check that the distance, cf. the table below, between spacer and coupling part pump corresponds to the actual coupling size which appears from the coupling element itself.

Thread	Torque	Coupling element	Distance
M8	25 Nm	V1700-0832	4 mm
M10	50 Nm	V1700-1042	4 mm
M12	90 Nm	V1700-1242	6 mm
M14	140 Nm	V1700-1442	6 mm

Ø330/415/418/465/525

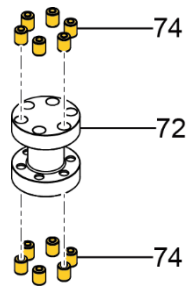
<p>1. Check Allen screws (76) and coupling bushes (74) for damage and clean these with a cloth. Replace them in case of damage.</p>	
<p>2. Remove grease from the screw threads by means of benzene, and clean the threaded holes in the coupling halves for pump and motor by means of pressure air. If new coupling halves are mounted, also remove grease from the threaded holes by means of benzene.</p>	
<p>3. Place coupling bushes (74) in the top holes of the spacer (72), the chamfering on the bushes is to face downwards. Place the coupling bush in the bottom holes of the spacer, the chamfering on the bushes is to face upwards. Hold the hand under the spacer and the bottom coupling bushes and carefully push the spacer into place.</p>	

4. Secure the coupling part pump (70) to the shaft by means of the pointed screw (73).

If the vertical gap (paint thickness not considered) between bearing bracket and coupling is less than 1 mm the pump ball bearing(s) shall most likely be replaced.

Hint: After bearing replacement (or on a new pump) record the vertical gap as reference value for later inspections.

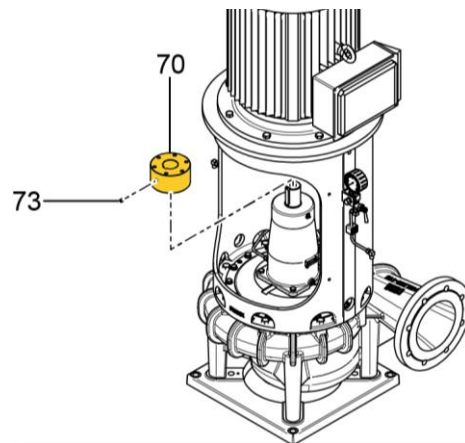

5. Apply Loctite type 242 on the allen screws (Loctite 242 is recommended as it will allow dismantling) and tighten all screws with the torque wrench. It might be necessary to push the spacer a little until the screws have located in the thread and you feel that the spacer has found the right position.

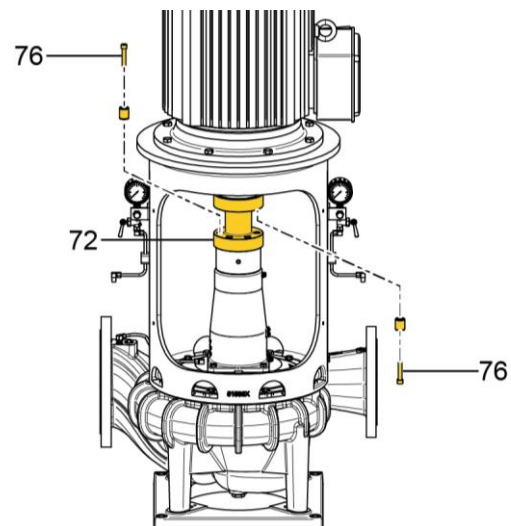

6. Fit guard (69).

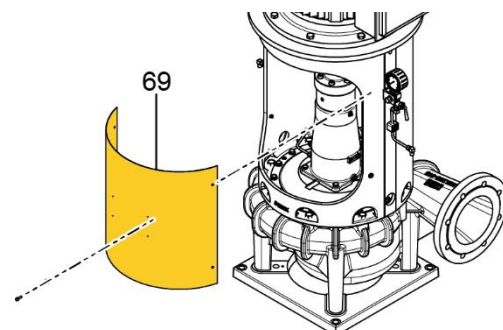

NOTE: Tighten the screws(76) with a torque wrench at 55 Nm. As motor/pump shaft will rotate during this operation it is necessary to hold the spacer by wedging a pin bolt, a piece of flat bar or the like between the two following screw heads in order to lock the system while the screws are tightened.

11. ORDERING SPARE PARTS

When ordering spare parts please always state pump type, serial No. (appears on the name plate of the pump), position No. on the assembly drawing and designation on the spare parts list.

Spare parts or Spare Parts Kit (SPK) can be ordered via spareparts@desmi.com

Recommended spare parts stock for 2 years' operation to DIN 24296.

Quantity of spare parts for recommended spare parts stock.

NSL /-02 combination

Part No.	Description	Number of pumps (including stand-by pumps)						
		2	3	4	5	6 and 7	8 and 9	10 and more
17	Shaft	1	1	1	2	2	2	20%
5	Impeller	1	1	1	2	2	2	20%
21	O-ring	4	6	8	8	9	10	100%
10	Mechanical seal	1	1	2	2	2	3	25%
4	Casing wear ring	2	2	2	3	3	4	50%
27 (only for 330/415/418/465/525)	Rear cover wear ring	2	2	2	3	3	4	50%
13	Bearing	2	2	2	3	3	4	50%
12	Snap ring	2	2	2	3	3	4	50%
11	Water deflector	2	2	2	3	3	4	50%
	SPK	2	2	2	3	3	4	50%

NSL /-12 combination

Part No.	Description	Number of pumps (including stand-by pumps)						
		2	3	4	5	6 and 7	8 and 9	10 and more
17	Shaft	1	1	1	2	2	2	20%
5	Impeller	1	1	1	2	2	2	20%
21	O-ring	4	6	8	8	9	10	100%
10	Mechanical seal	1	1	2	2	2	3	25%
4	Casing wear ring	2	2	2	3	3	4	50%
27(only for 330/415/418 /465/525)	Rear cover wear ring	2	2	2	3	3	4	50%
	SPK	2	2	2	3	3	4	50%

NSL /-13/14 combinations

Part No.	Description	Number of pumps (including stand-by pumps)						
		2	3	4	5	6 and 7	8 and 9	10 and more
17	Shaft	1	1	1	2	2	2	20%
5	Impeller	1	1	1	2	2	2	20%
21	O-ring	4	6	8	8	9	10	100%
10	Mechanical seal	1	1	2	2	2	3	25%
4	Casing wear ring	2	2	2	3	3	4	50%
27(only for 330/415/418 /465/525)	Rear cover wear ring	2	2	2	3	3	4	50%
13	Bearing	2	2	2	3	3	4	50%
15	Bearing	2	2	2	3	3	4	50%
12	Snap ring	2	2	2	3	3	4	50%
11	Water deflector	2	2	2	3	3	4	50%
	SPK	2	2	2	3	3	4	50%

11.1. Assembly drawing NSL-215/265 -02 combination

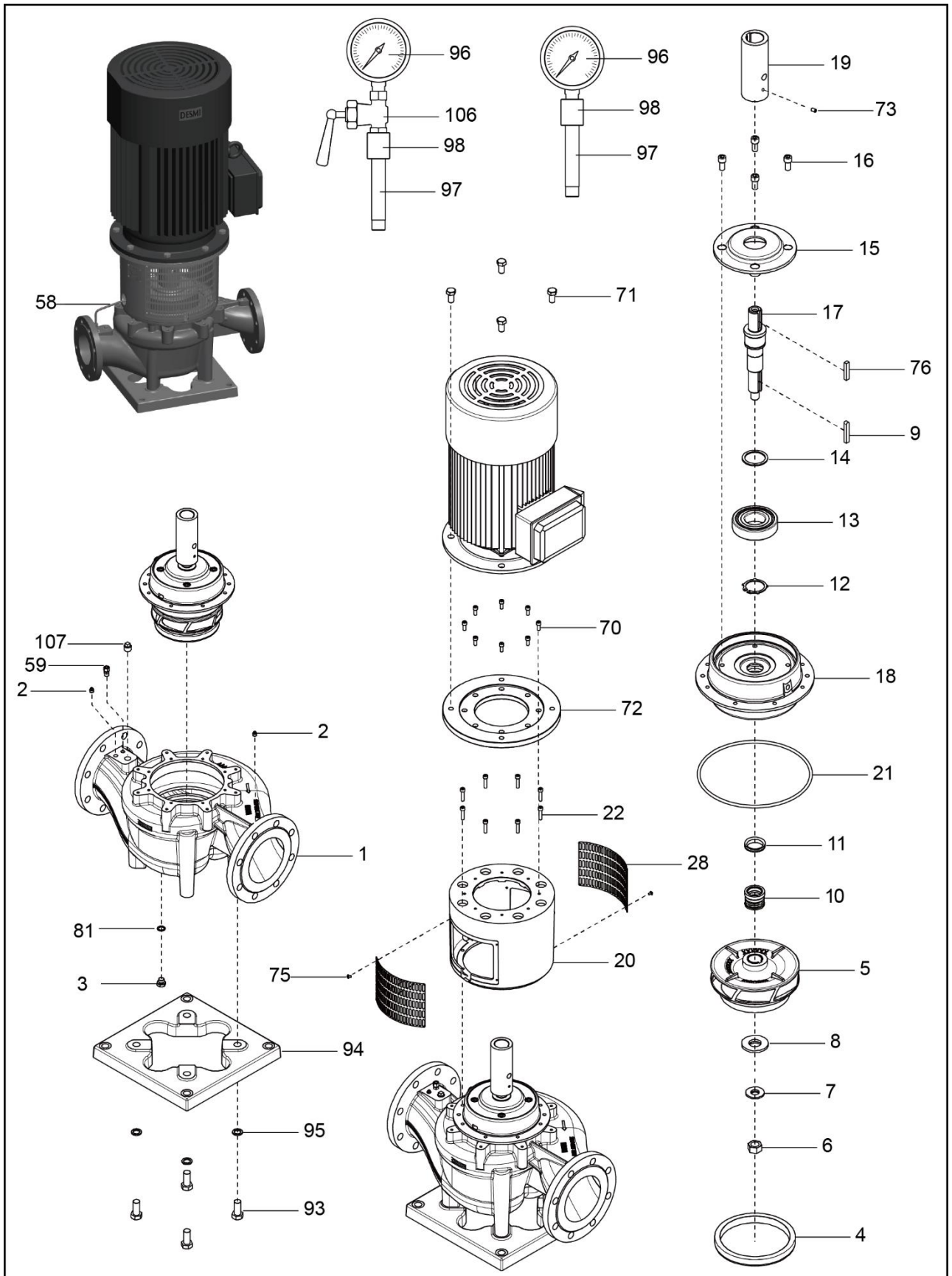

11.2. Spare parts list NSL-215/265 -02 combination

Pos. No	Description	Pos. No	Description
1	Pump casing	21	O-ring
2	Pipe plug	22	Allen screw
3	Pipe plug	28	Guard
4	Sealing ring	58	Pipe
5	Impeller	59	Hexagon nipple
6	Nut	70	Allen screw
7	Spring washer	71	Set screw
8	Washer	72	Intermediate flange
9	Sunk key	73	Pointed screw
10	Shaft seal	75	INSEX-screw
11	Water deflector	76	Sunk key
12	Ring lock	81	Sealing washer
13	Ball bearing	93	Set screw
14	Support disc	94	Base plate
15	Bearing cover	95	Lock washer
16	Allen screw	96	Manometer
17	Shaft	97	Nipple
18	Rear cover	98	Sleeve
19	Coupling	106	Gauge valve
20	Motor bracket	107	Pipe plug

11.3. Assembly drawing NSL-215/265 -12 combination

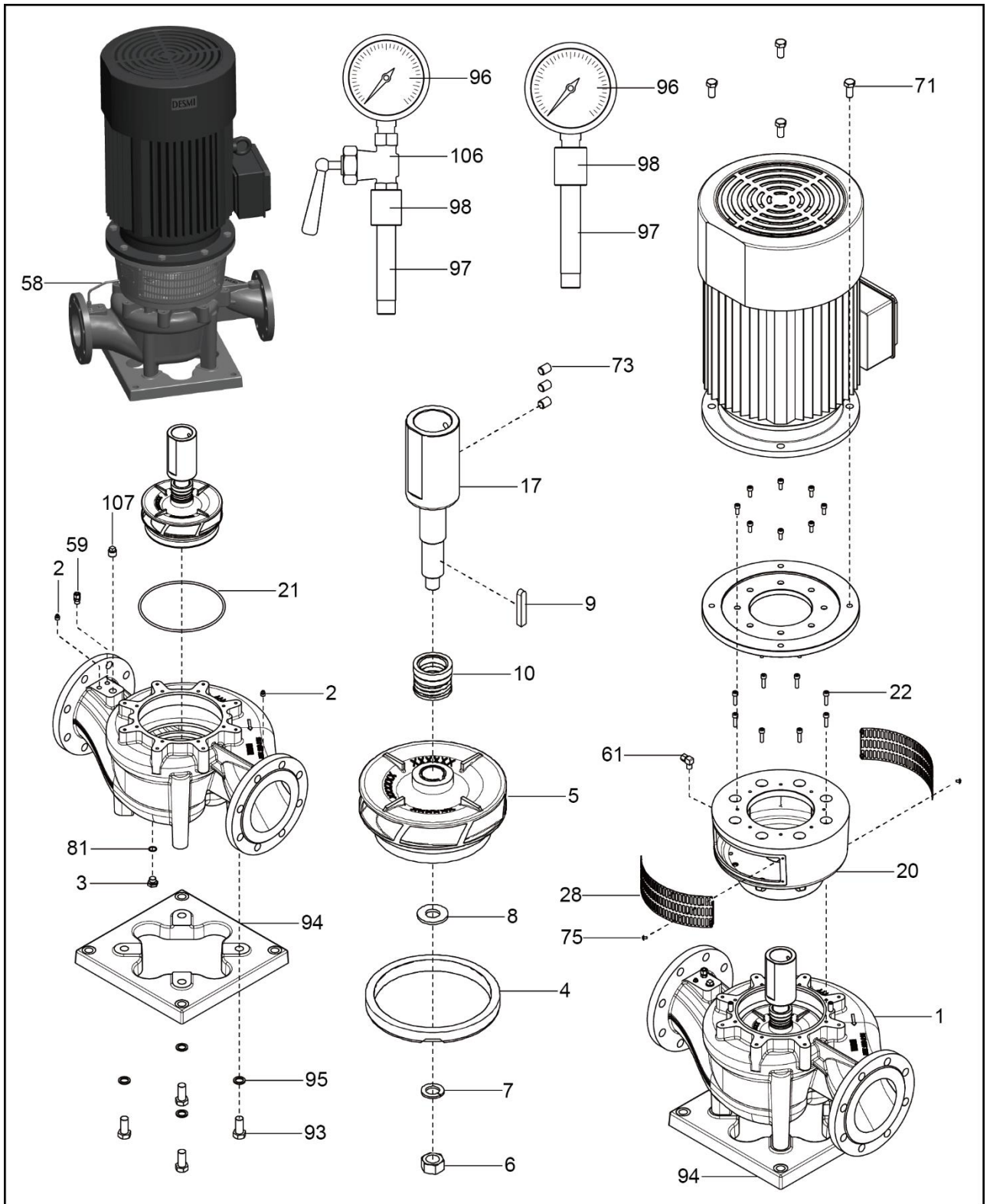

11.4. Spare parts list NSL-215/265 -12 combination

See stainless steel pump on the next pages

Pos. No	Description	Pos. No	Description
1	Pump casing	28	Guard
2	Pipe plug	58	Pipe
3	Pipe plug	59	Hexagon nipple
4	Sealing ring	71	Set screw
5	Impeller	73	Pointed screw
6	Nut	75	INSEX-screw
7	Spring washer	81	Sealing washer
8	Washer	93	Set screw
9	Sunk key	94	Base plate
10	Mechanical shaft seal	95	Lock washer
17	Shaft	96	Manometer
20	Motor bracket	97	Nipple
21	O-ring	98	Sleeve
22	Allen screw	107	Pipe plug

The pump has various options and combinations for the wet part material to fulfil desired applications.

11.5. Assembly drawing NSL-215/265 -S12 combination

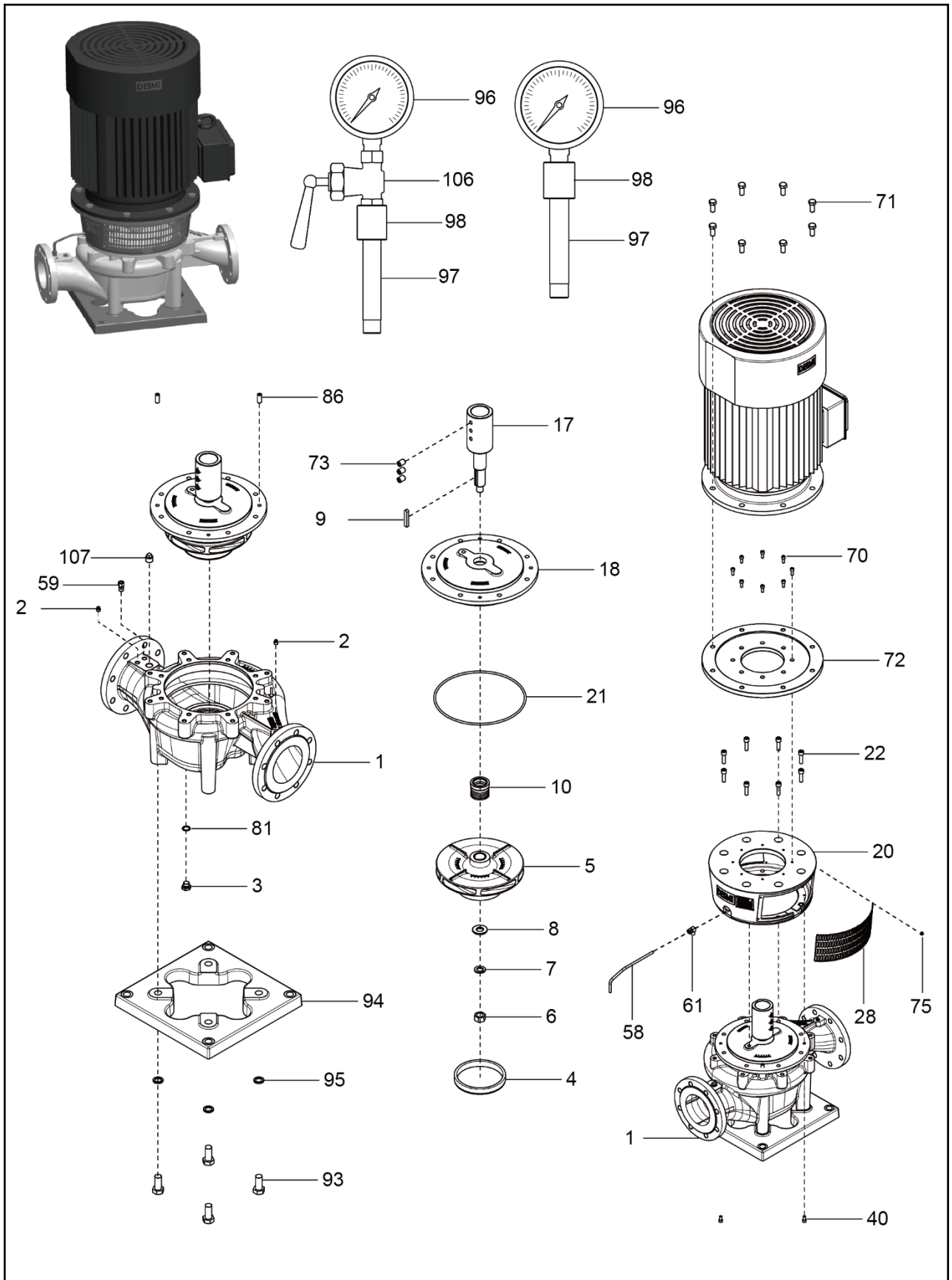

11.6. Spare parts list NSL-215/265 -S12 combination

Pos. No	Description	Pos. No	Description
1	Pump casing	40	Allen screw
2	Pipe plug	58	Pipe
3	Pipe plug	59	Hexagon nipple
4	Sealing ring	70	Allen screw *
5	Impeller	71	Set screw
6	Nut	72	Interm. flange *
7	Spring washer	73	Pointed screw
8	Washer	75	INSEX-screw
9	Sunk key	81	Sealing washer
10	Mech. Shaft seal	93	Set screw
17	Shaft	94	Base plate
18	Rear cover	95	Lock washer
20	Motor bracket	96	Manometer
21	O-ring	97	Nipple
22	Allen screw	98	Sleeve
28	Guard	107	Pipe plug

*) Only if motor flange is bigger than bracket.

11.7. Assembly drawing NSL-330/415/465 -02 combination

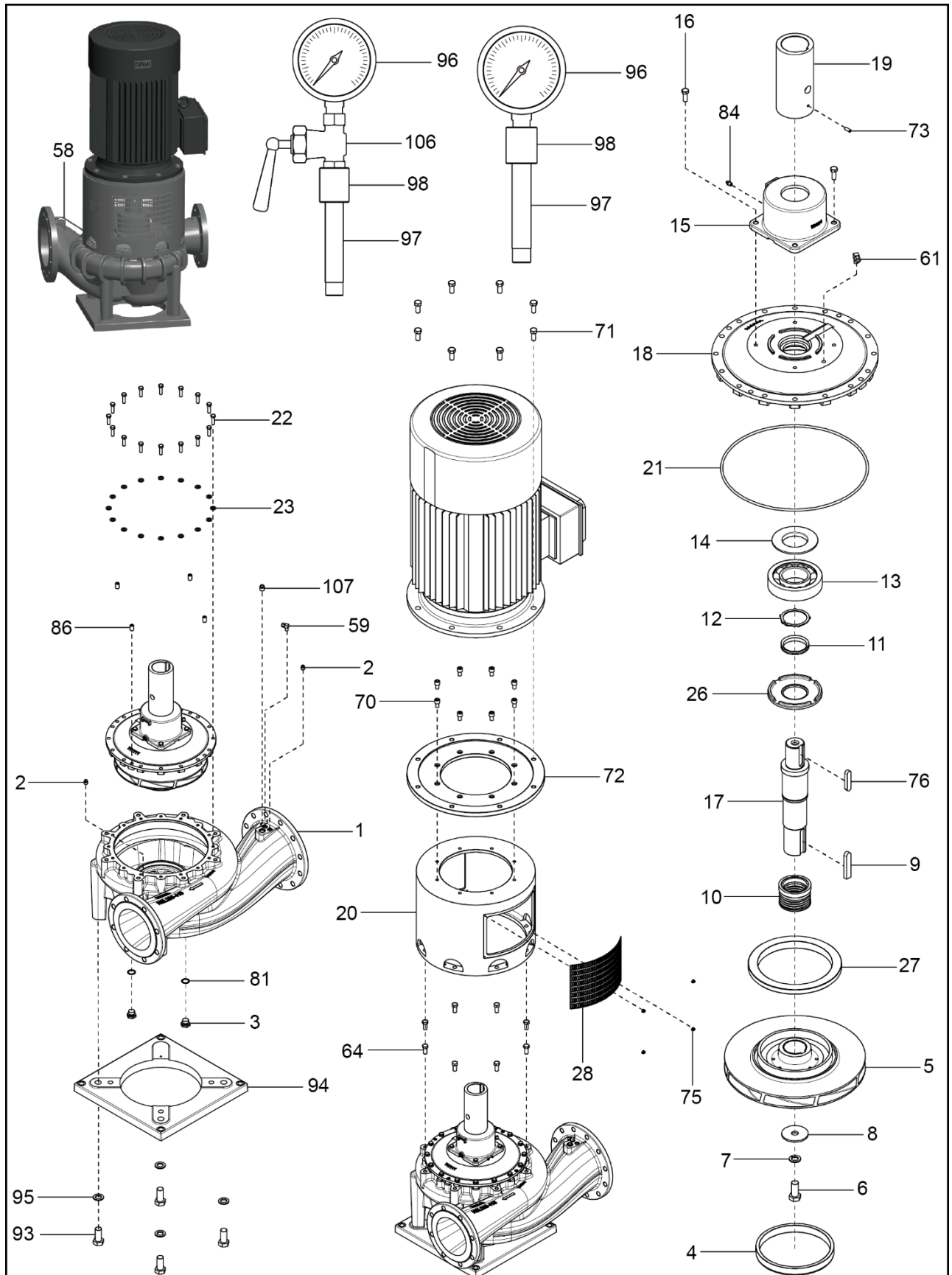

11.8. Spare parts list NSL-330/415/465 -02 combination

Pos. No	Description	Pos. No	Description
1	Pump casing	27	Sealing ring 2
2	Pipe plug	28	Guard
3	Pipe plug	58	Pipe
4	Sealing ring	59	Hexagon nipple
5	Impeller	61	Hexagon nipple
6	Set screw	64	Set screw
7	Spring washer	70	Allen screw
8	Washer	71	Set screw
9	Sunk key	72	Intermediate flange
10	Mech. Shaft seal	73	Pointed screw
11	Water deflector	75	INSEX-screw
12	Ring lock	76	Sunk key
13	Ball bearing	81	Sealing washer
14	Grease valve ring *	84	Lubricator nipple
15	Bearing cover	86	Pointed screw
16	Set screw	93	Set screw
17	Shaft	94	Base plate
18	Rear cover	95	Lock washer
19	Coupling	96	Manometer
20	Motor bracket	97	Nipple
21	O-ring	98	Sleeve
22	Set screw	106	Gauge valve
23	Lock washer	107	Pipe plug
26	Cover under bearing *1		

*) Support disc in light bearing housing

*1) Option – See Appendix B

11.10. Spare parts list NSL-330/415/465 -12 combination

Pos. No	Description	Pos. No	Description
1	Pump casing	28	Guard
2	Pipe plug	58	Pipe
3	Pipe plug	59	Hexagon nipple
4	Sealing ring	64	Set screw
5	Impeller	71	Set screw
6	Set screw	73	Pointed screw
7	Spring washer	75	INSEX-screw
8	Washer	81	Sealing washer
9	Sunk key	86	Pointed screw
10	Mech. shaft seal	93	Set screw
17	Shaft	94	Base plate
18	Rear cover	95	Lock washer
20	Motor bracket	96	Manometer
21	O-ring	97	Nipple
22	Set screw	98	Sleeve
23	Lock washer	106	Gauge valve
27	Sealing ring 2	107	Pipe plug

11.11. Assembly drawing NSL300-418 -02 combination

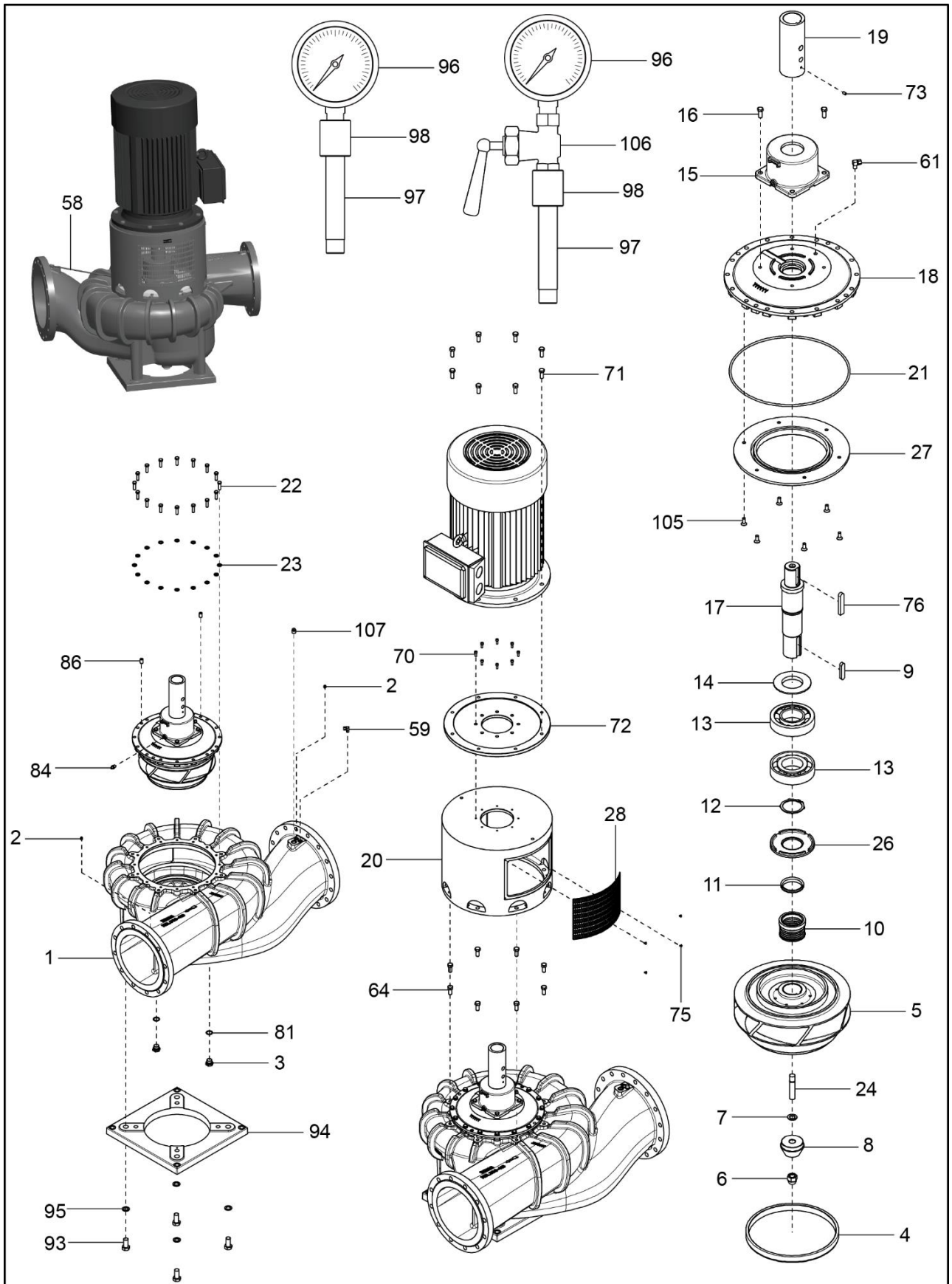

11.12. Spare parts list NSL300-418 -02 combination

Pos. No	Description	Pos. No	Description
1	Pump casing	27	Sealing ring 2
2	Pipe plug	28	Guard
3	Pipe plug	58	Pipe
4	Sealing ring	59	Hexagon nipple
5	Impeller	61	Hexagon nipple
6	Nut	64	Set screw
7	Spring washer	70	Allen screw
8	Inlet cone	71	Set screw
9	Sunk key	72	Intermediate flange
10	Mech. shaft seal	73	Pointed screw
11	Water deflector	75	INSEX-screw
12	Ring lock	76	Sunk key
13	Ball bearing	81	Sealing washer
14	Grease valve ring	84	Lubricator nipple
15	Bearing cover	86	Pointed screw
16	Set screw	93	Set screw
17	Shaft	94	Base plate
18	Rear cover	95	Lock washer
19	Coupling	96	Manometer
20	Motor bracket	97	Nipple
21	O-ring	98	Sleeve
22	Set screw	105	Counter sunk screw
23	Lock washer	106	Gauge valve
24	Stud	107	Pipe plug
26	Cover under bearing*		

*) Option – See Appendix B

11.13. Assembly drawing NSL300-418 -12 combination

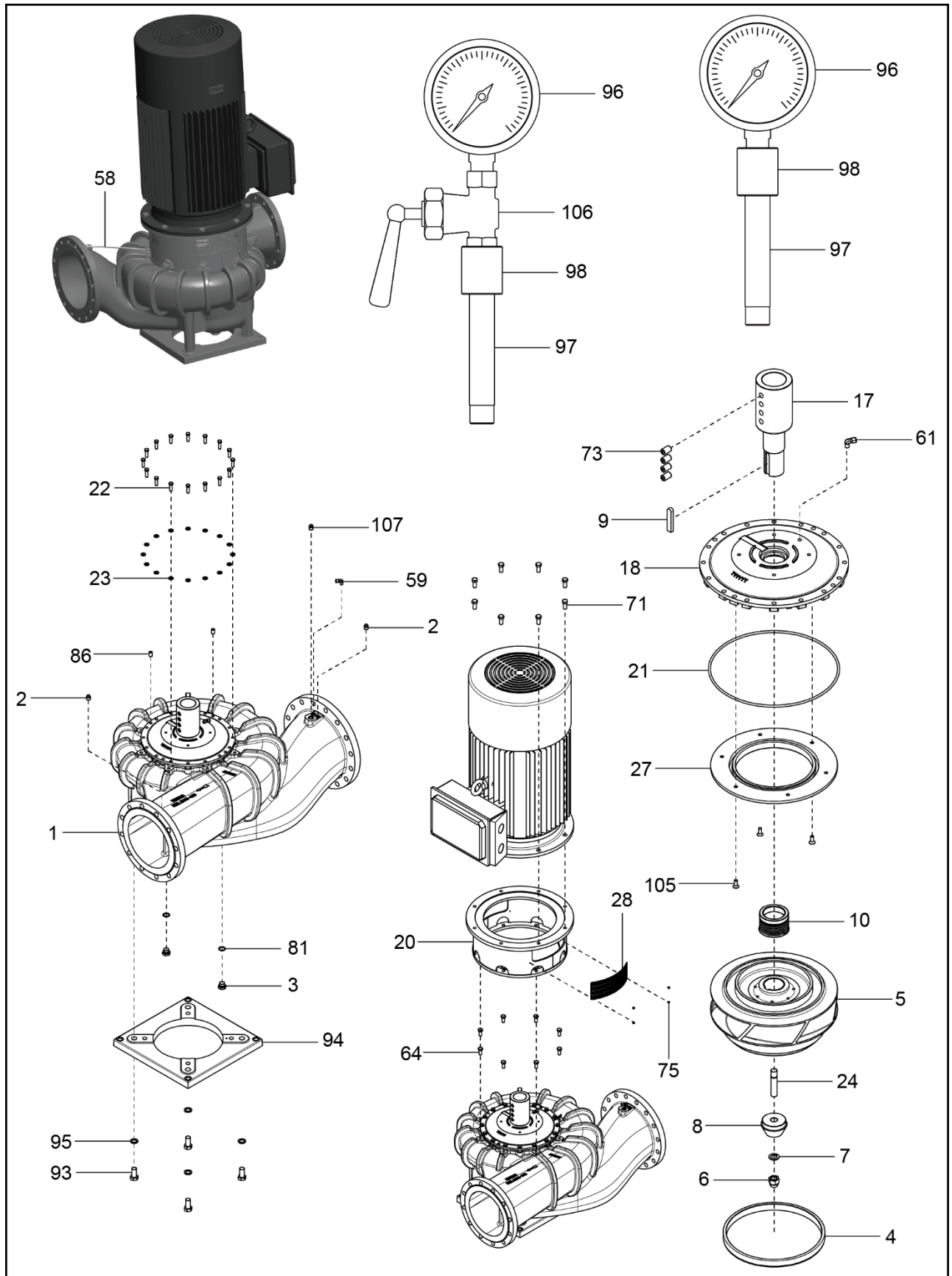

11.14. Spare parts list NSL300-418 -12 combination

Pos. No	Description	Pos. No	Description
1	Pump casing	58	Pipe
2	Pipe plug	59	Hexagon nipple
3	Pipe plug	61	Hexagon nipple
4	Sealing ring	64	Set screw
5	Impeller	71	Set screw
6	Nut	73	Pointed screw
7	Spring washer	75	INSEX-screw
8	Inlet cone	81	Sealing washer
9	Sunk key	86	Pointed screw
10	Mech. shaft seal	93	Set screw
17	Shaft	94	Base plate
18	Rear cover	95	Lock washer
20	Motor bracket	96	Manometer
21	O-ring	97	Nipple
22	Set screw	98	Sleeve
23	Lock washer	105	Counter sunk screw
24	Stud	106	Gauge valve
27	Sealing ring 2	107	Pipe plug
28	Guard		

11.15. Assembly drawing NSL200/250/300-525 -02 combination

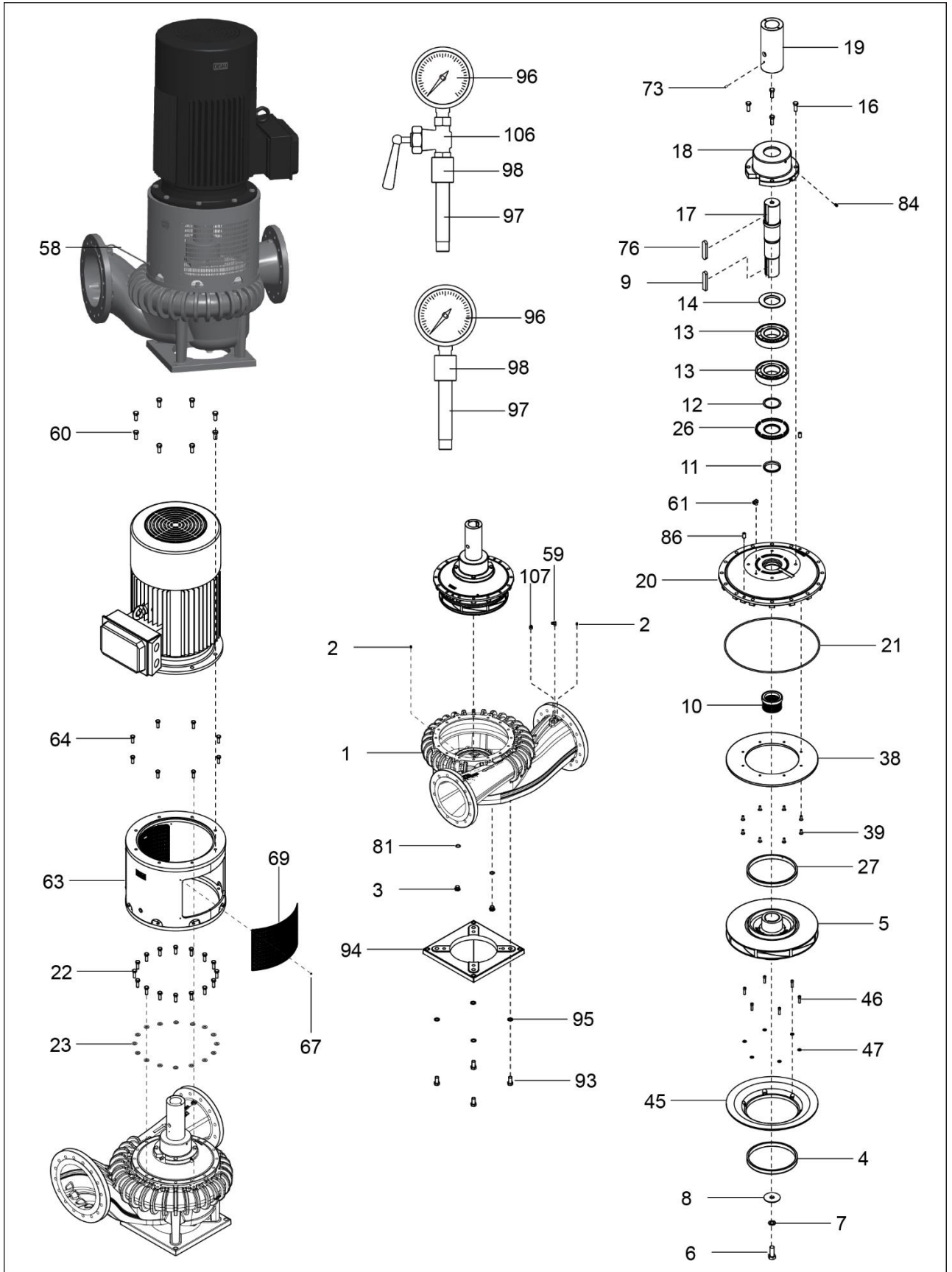

11.16. Spare parts list NSL200/250/300-525 -02 combination

Pos. No	Description	Pos. No	Description
1	Pump casing	39	Counter sunk screw
2	Pipe plug	45	Guide plate (only for NSL300-525)
3	Pipe plug	46	Allan screw
4	Sealing ring	47	Washer
5	Impeller	58	Pipe
6	Set screw	59	Hexagon nipple
7	Spring collar	60	Set screw
8	Inlet cone	61	Hexagon nipple
9	Sunk key	63	Bracket
10	Mech. shaft seal	64	Set screw
11	Water deflector	67	Set screw
12	Ring lock	69	Guard
13	Ball bearing	73	Pointed screw
14	Grease valve ring	76	Sunk key
16	Set screw	81	Sealing washer
17	Shaft	84	Lubricator nipple
18	Bearing housing	86	Pointed screw
19	Coupling	93	Set screw
20	Rear cover	94	Base plate
21	O-ring	95	Lock washer
22	Set screw	96	Manometer
23	Lock washer	97	Reducing nipple
26	Cover under bearing *	98	Hexagon nipple
27	Sealing ring 2	106	Gauge valve
38	Guide plate	107	Pipe plug

*) Option – See Appendix B

11.17. Assembly drawing NSL200/250/300-525 -12 combination

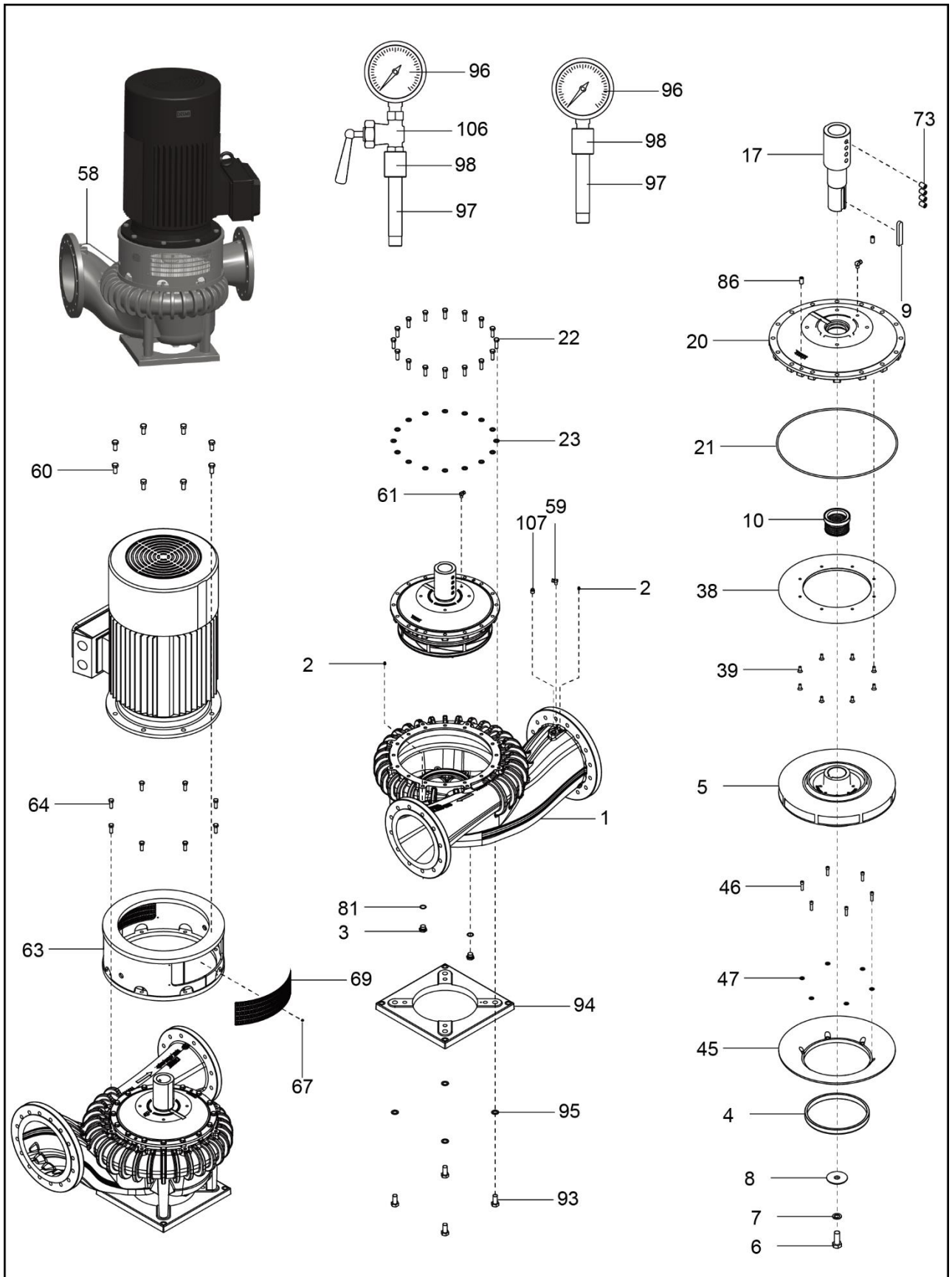

11.18. Spare parts list NSL200/250/300-525 -12 combination

Pos. No	Description	Pos. No	Description
1	Pump casing	58	Pipe
2	Pipe plug	59	Hexagon nipple
3	Pipe plug	60	Set screw
4	Sealing ring	61	Hexagon nipple
5	Impeller	63	Bracket
6	Set screw	64	Set screw
7	Spring collar	67	Set screw
8	Inlet cone	69	Guard
9	Sunk key	73	Pointed screw
10	Mech. shaft seal	81	Sealing washer
17	Shaft	86	Pointed screw
20	Rear cover	93	Set screw
21	O-ring	94	Base plate
22	Set screw	95	Lock washer
23	Lock washer	96	Manometer
38	Guide plate	97	Reducing nipple
39	Counter sunk screw	98	Hexagon nipple
45	Guide plate (only for NSL300-525)	106	Gauge valve
46	Allan screw	107	Pipe plug
47	Washer		

11.19. Assembly drawing NSL350-525 -02 combination

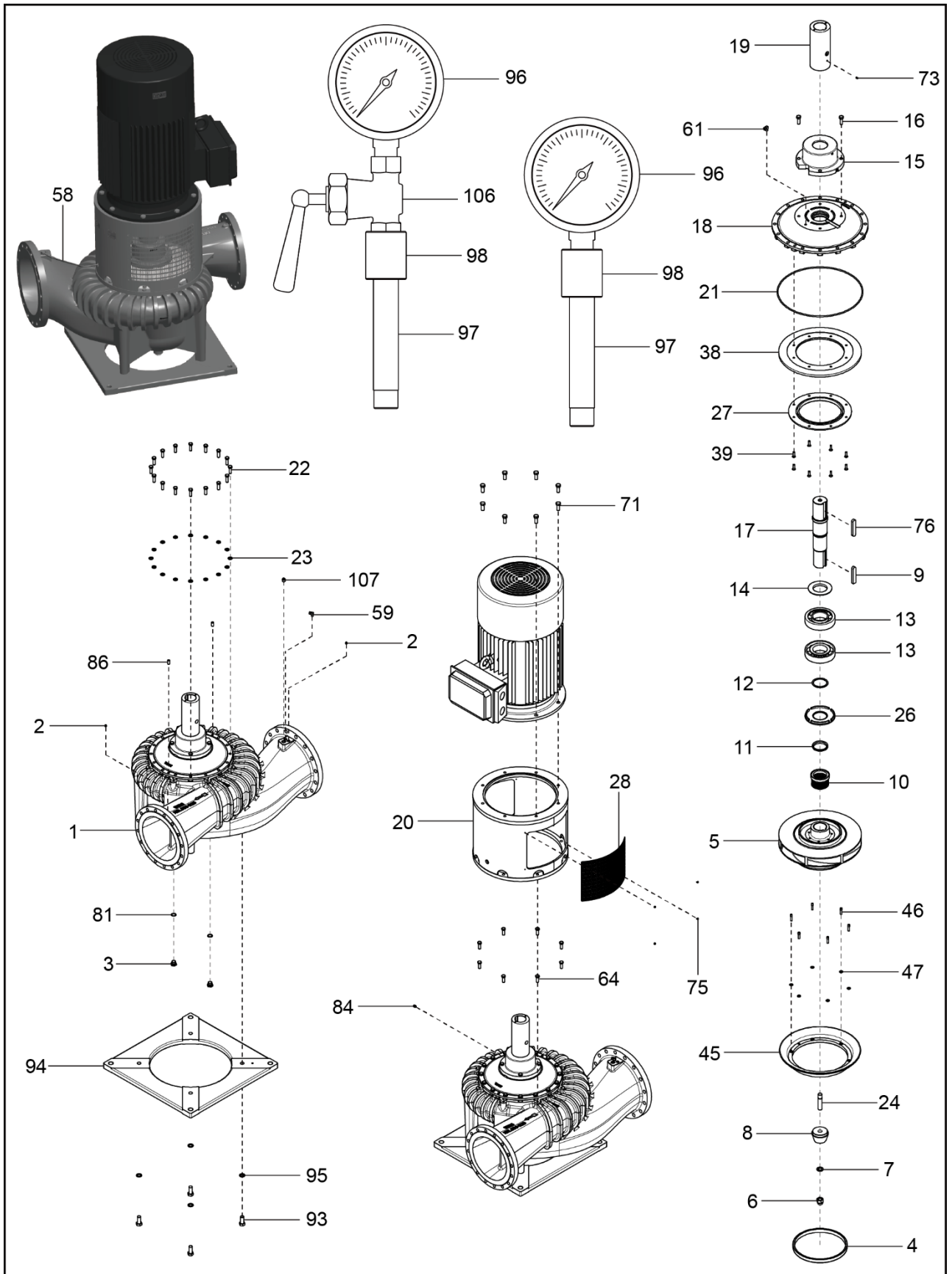

11.20. Spare parts list NSL350-525 -02 combination

Pos. No	Description	Pos. No	Description
1	Pump casing	28	Guard
2	Pipe plug	38	Guard plate
3	Pipe plug	39	Counter sunk screw
4	Sealing ring	45	Guard Plate
5	Impeller	46	Screw
6	Nut	47	Washer
7	Spring washer	58	Pipe
8	Inlet cone	59	Hexagon nipple
9	Sunk key	61	Hexagon nipple
10	Mech. shaft seal	64	Set screw
11	Water deflector	71	Set screw
12	Ring lock	73	Pointed screw
13	Ball bearing	75	INSEX-screw
14	Grease valve ring	76	Sunk key
15	Bearing cover	81	Sealing washer
16	Set screw	84	Lubricator nipple
17	Shaft	86	Pointed screw
18	Rear cover	93	Set screw
19	Coupling	94	Base plate
20	Motor bracket	95	Lock washer
21	O-ring	96	Manometer
22	Set screw	97	Nipple
23	Lock washer	98	Sleeve
24	Stud	106	Gauge valve
26	Cover under bearing*	107	Pipe plug
27	Sealing ring 2		

*) Option – See Appendix B

11.21. Assembly drawing NSL350-525 -12 combination

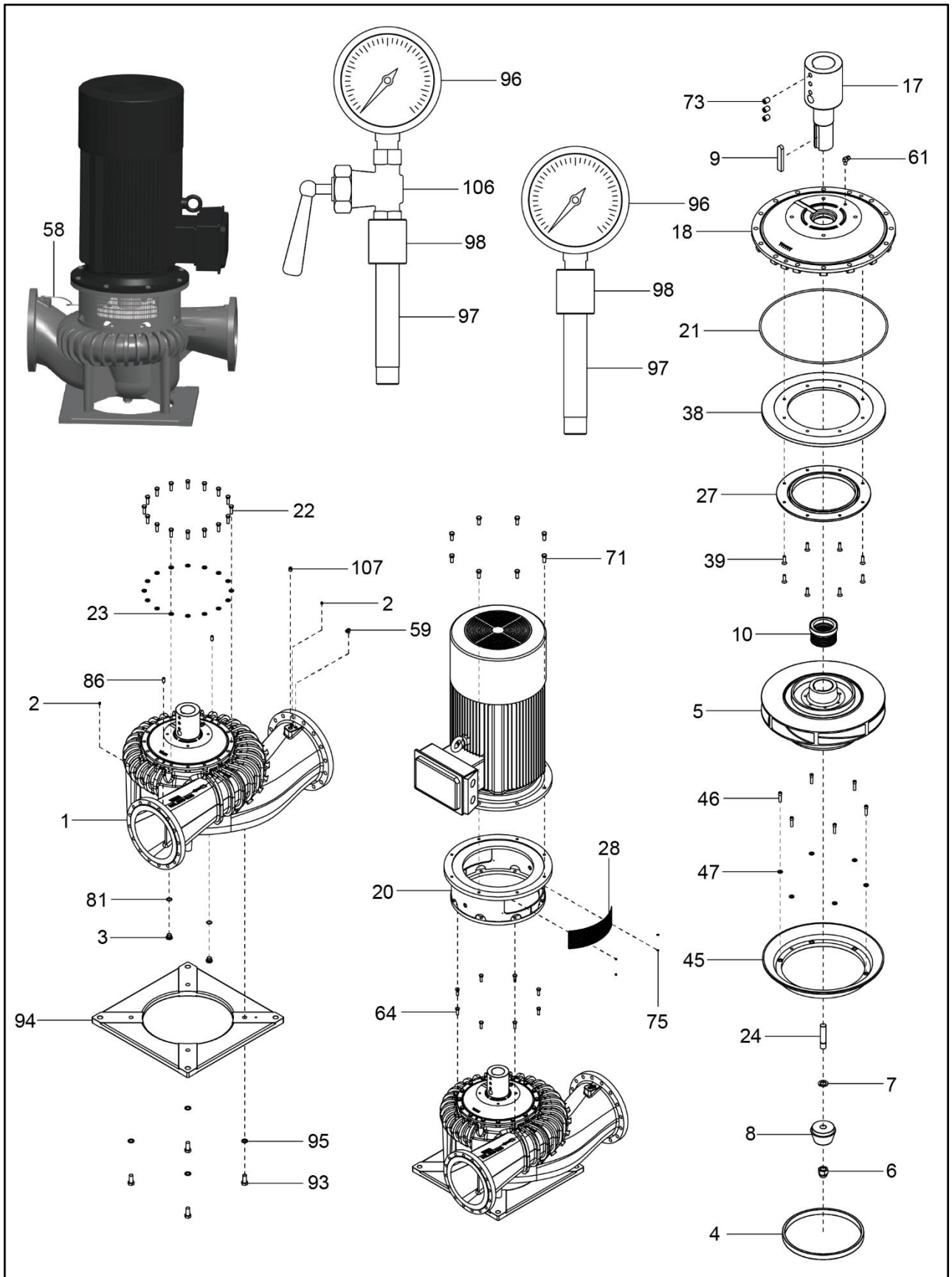

11.22. Spare parts list NSL350-525 -12 combination

Pos. No	Description	Pos. No	Description
1	Pump casing	45	Guard Plate
2	Pip eplug	46	Screw
3	Pipe plug	47	Washer
4	Sealing ring	58	Pipe
5	Impeller	59	Hexagon nipple
6	Nut	61	Hexagon nipple
7	Spring washer	64	Set screw
8	Inlet cone	71	Set screw
9	Sunk key	73	Pointed screw
10	Mech. shaft seal	75	INSEX-screw
17	Shaft	81	Sealing washer
18	Rear cover	86	Pointed screw
20	Motor bracket	93	Set screw
21	O-ring	94	Base plate
22	Set screw	95	Lock washer
23	Lock washer	96	Manometer
24	Stud	97	Nipple
27	Sealing ring 2	98	Sleeve
28	Guard	106	Gauge valve
38	Guard plate	107	Pipe plug
39	Counter sunk screw		

11.24. Spare parts list NSL-215/265 -14 combination

Also applies to /-13 or /-15 design.

Pos. No	Description	Pos. No	Description
1	Pump casing	67	Set screw
2	Pipe plug	69	Guard
3	Pipe plug	70	Coupling part pump
4	Sealing ring	71	Coupling part motor
5	Impeller	72	Spacer
6	Nut	73	Pointed screw
7	Spring washer	74	Elastomer
8	Washer	76	Allen screw
9	Sunk key	77	Allen screw
10	Mech. shaft seal	79	Nut
11	Water deflector	81	Sealing washer
12	Ring lock	84	Lubricator nipple *
13	Ball bearing	86	Pointed screw
14	Support disc	93	Set screw
15	Ball bearing	94	Base plate
16	Sunk key	95	Lock washer
17	Shaft	96	Manometer
18	Bearing housing	97	Reducing nipple
19	Allen screw	98	Hexagon nipple
20	Rear cover	99	T-piece
21	O-ring	100	Bulkhead connection
22	Allen screw	101	Screw cap
58	Pipe	103	Pipe
59	Hexagon nipple	106	Gauge valve
60	Set screw	107	Pipe plug
63	Bracket	109	Set screw
64	Set screw	110	Manometer fitting

*) Only combination 14

11.25. Assembly drawing NSL-330/415/465 -14 combination

Also applies to /-13 design.

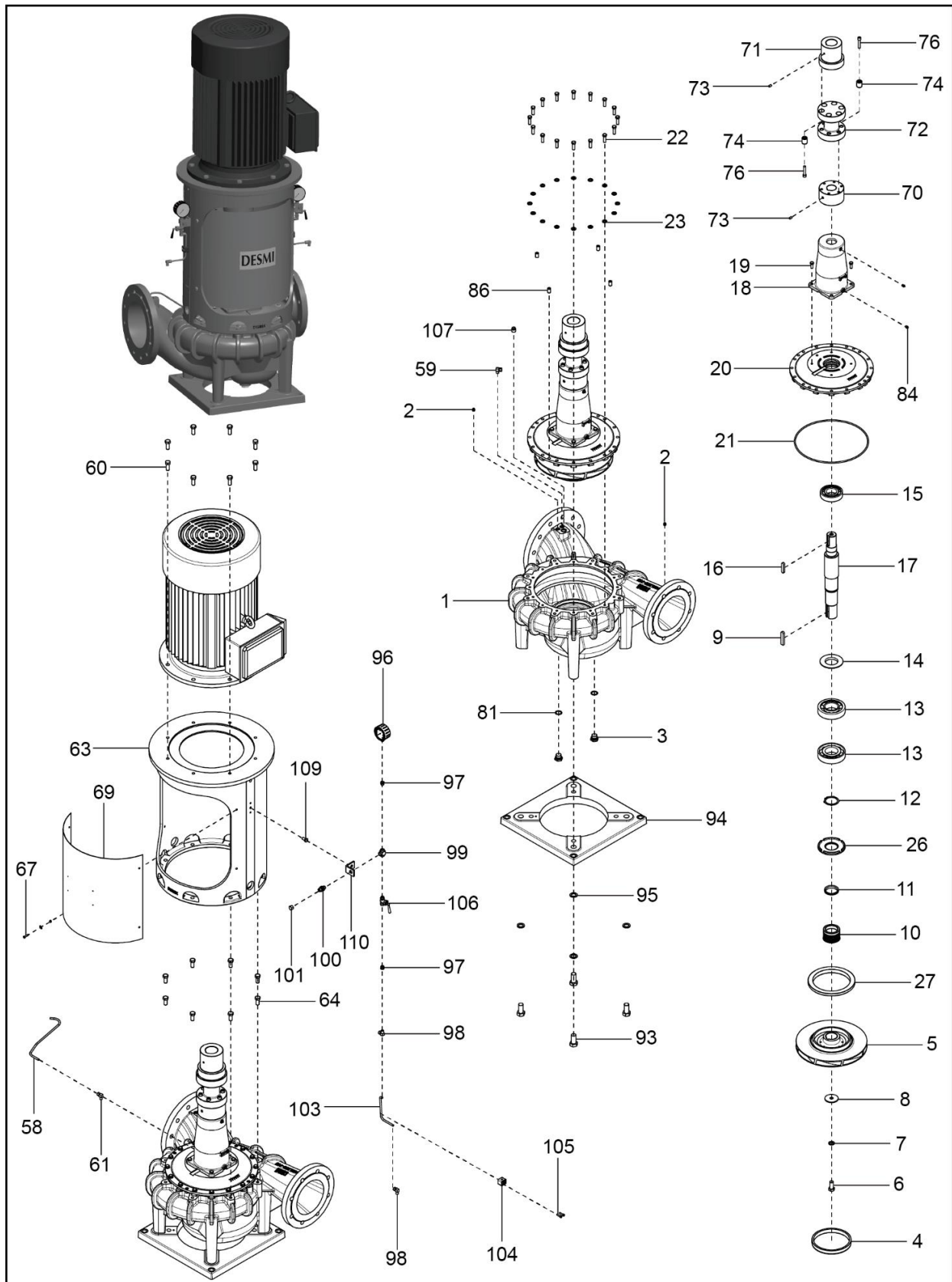

11.26. Spare parts list NSL-330/415/465 -14 combination

Also applies to /-13 design.

Pos. No	Description	Pos. No	Description
1	Pump casing	63	Bracket
2	Pipe plug	64	Set screw
3	Pipe plug	67	Set screw
4	Sealing ring	69	Guard
5	Impeller	70	Coupling part pump
6	Set screw	71	Coupling part motor
7	Spring collar	72	Spacer
8	Washer	73	Pointed screw
9	Sunk key	74	Coupling bush
10	Mech. shaft seal	76	Allen screw
11	Water deflector	81	Sealing washer
12	Ring lock	84	Lubricator nipple
13	Ball bearing	86	Pointed screw
14	Grease valve ring *	93	Set screw
15	Ball bearing	94	Base plate
16	Sunk key	95	Lock washer
17	Shaft	96	Manometer
18	Bearing housing	97	Reducing nipple
19	Set screw	98	Hexagon nipple
20	Rear cover	99	T-piece
21	O-ring	100	Bulkhead connection
22	Set screw	101	Screw cap
23	Lock washer	103	Pipe
26	Cover under bearing *1	104	Pipe clamp
27	Sealing ring 2	105	Allen screw
58	Pipe	106	Gauge valve
59	Hexagon nipple	107	Pipe plug
60	Set screw	109	Set screw
61	Hexagon nipple	110	Manometer fitting

*) Support disc in comb.13.

*1) Option – See Appendix B

11.27. Assembly drawing NSL300-418 -14 combination

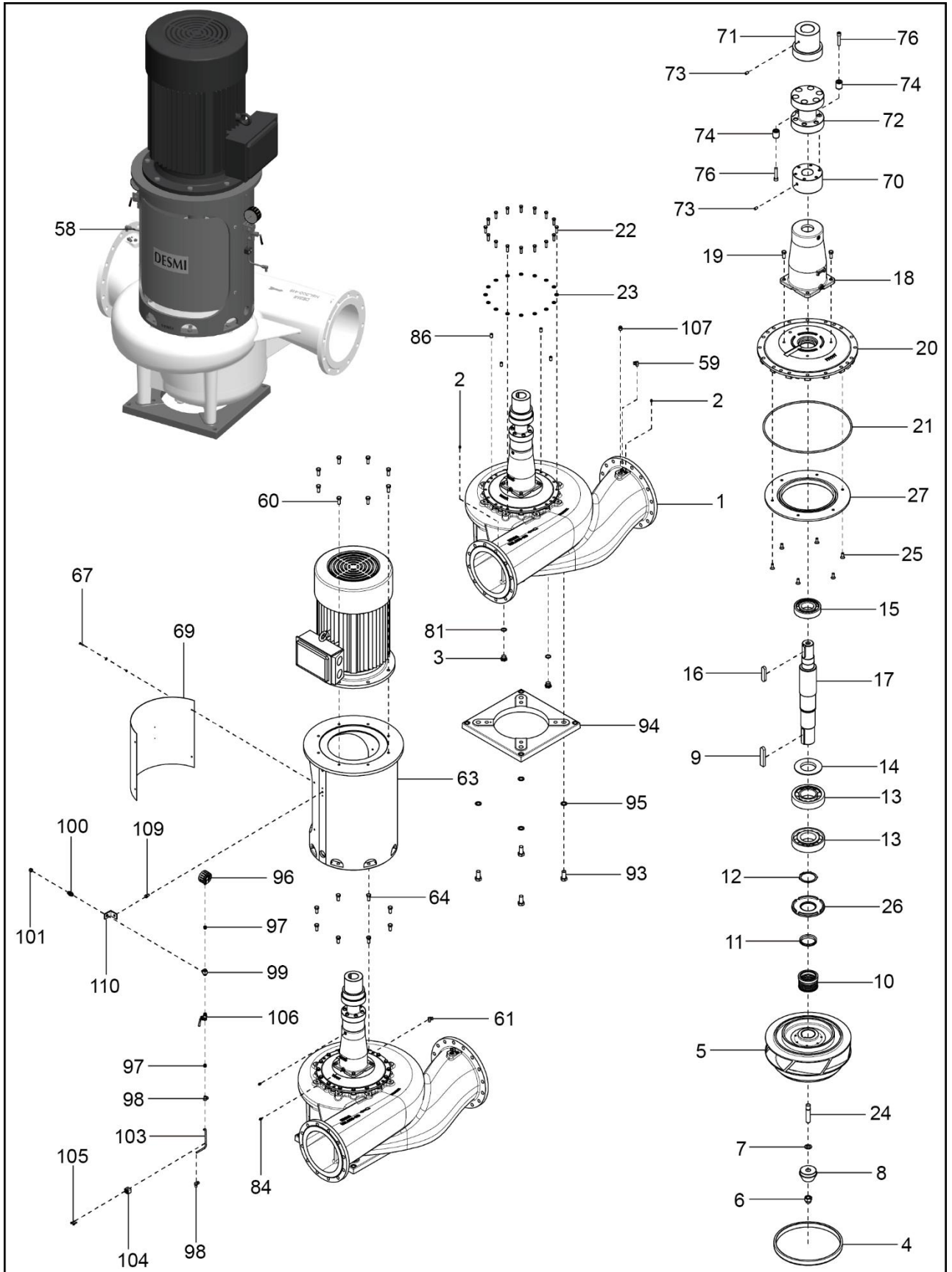

11.28. Spare parts list NSL300-418 -14 combination

Pos. No	Description	Pos. No	Description
1	Pump casing	61	Hexagon nipple
2	Pipe plug	63	Bracket
3	Pipe plug	64	Set screw
4	Sealing ring	67	Set screw
5	Impeller	69	Guard
6	Cap nut	70	Coupling part pump
7	Spring collar	71	Coupling part motor
8	Inlet cone	72	Spacer
9	Sunk key	73	Pointed screw
10	Mech. shaft seal	74	Coupling bush
11	Water deflector	76	Allen screw
12	Ring lock	81	Sealing washer
13	Ball bearing	84	Lubricator nipple
14	Grease valve ring	86	Pointed screw
15	Ball bearing	93	Set screw
16	Sunk key	94	Base plate
17	Shaft	95	Lock washer
18	Bearing housing	96	Manometer
19	Set screw	97	Reducing nipple
20	Rear cover	98	Hexagon nipple
21	O-ring	99	T-piece
22	Set screw	100	Bulkhead connection
23	Lock washer	101	Screw cap
24	Stud	103	Pipe
25	Counter sunk screw	104	Pipe clamp
26	Cover under bearing *	105	Allen screw
27	Sealing ring 2	106	Gauge valve
58	Pipe	107	Pipe plug
59	Hexagon nipple	109	Set screw
60	Set screw	110	Manometer fitting

*) Option – See Appendix B

11.29. Assembly drawing NSL200/250/300-525 -14 combination

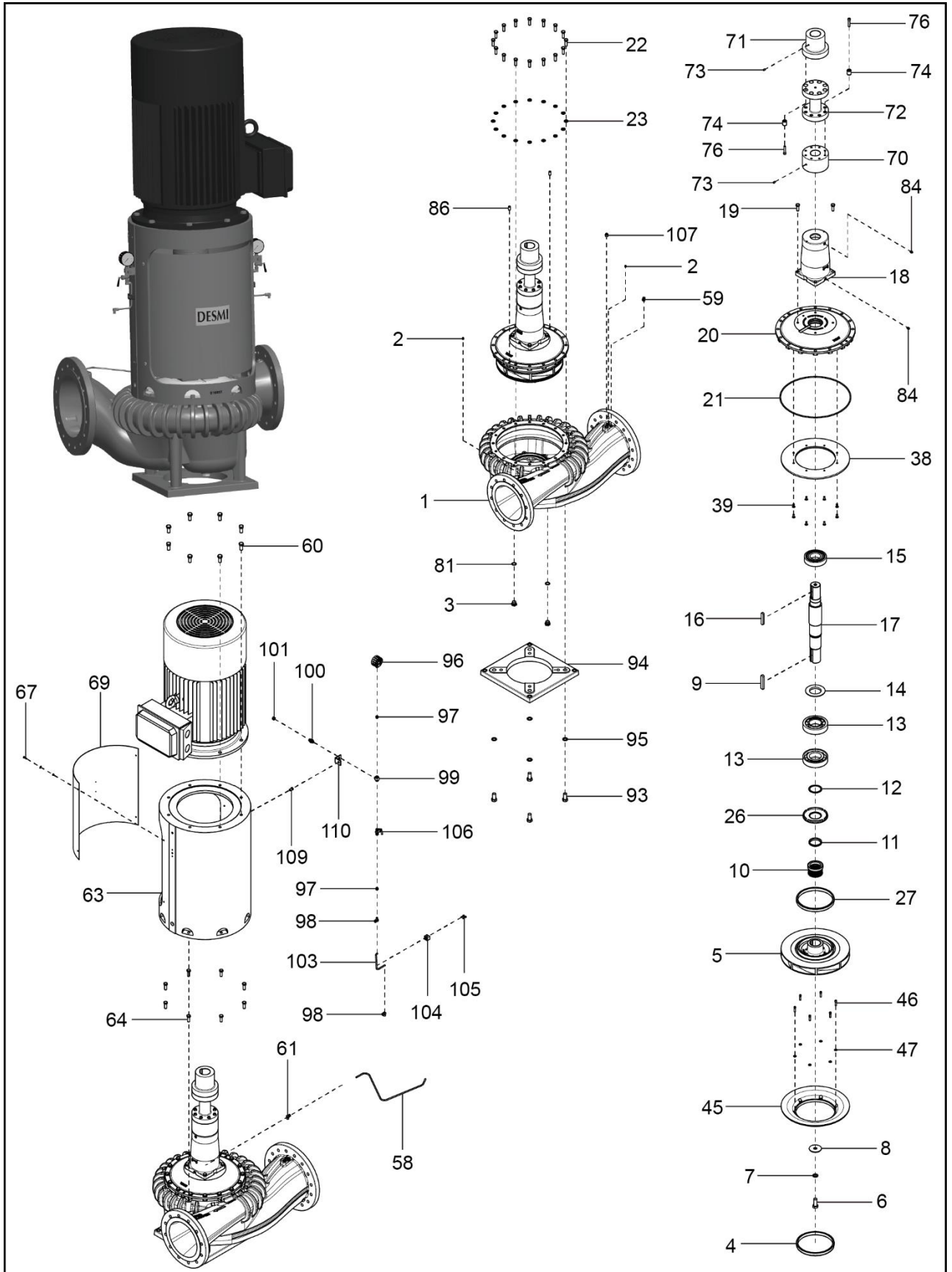

11.30. Spare parts list NSL200/250/300-525 -14 combination

Pos. No	Description	Pos. No	Description
1	Pump casing	60	Set screw
2	Pipe plug	61	Hexagon nipple
3	Pipe plug	63	Bracket
4	Sealing ring	64	Set screw
5	Impeller	67	Set screw
6	Set screw	69	Guard
7	Spring collar	70	Coupling part pump
8	Inlet cone	71	Coupling part motor
9	Sunk key	72	Spacer
10	Mech. shaft seal	73	Pointed screw
11	Water deflector	74	Coupling bush
12	Ring lock	76	Allen screw
13	Ball bearing	81	Sealing washer
14	Grease valve ring	84	Lubricator nipple
15	Ball bearing	86	Pointed screw
16	Sunk key	93	Set screw
17	Shaft	94	Base plate
18	Bearing housing	95	Lock washer
19	Set screw	96	Manometer
20	Rear cover	97	Reducing nipple
21	O-ring	98	Hexagon nipple
22	Set screw	99	T-piece
23	Lock washer	100	Bulkhead connection
26	Cover under bearing *	101	Screw cap
27	Sealing ring 2	103	Pipe
38	Guide plate	104	Pipe clamp
39	Counter sunk screw	105	Allen screw
45	Guide plate (only for NSL300-525)	106	Gauge valve
46	Allan screw	107	Pipe plug
47	Washer	109	Set screw
58	Pipe	110	Manometer fitting
59	Hexagon nipple		

*) Option – See Appendix B

11.31. Assembly drawing NSL350-525 -14 combination

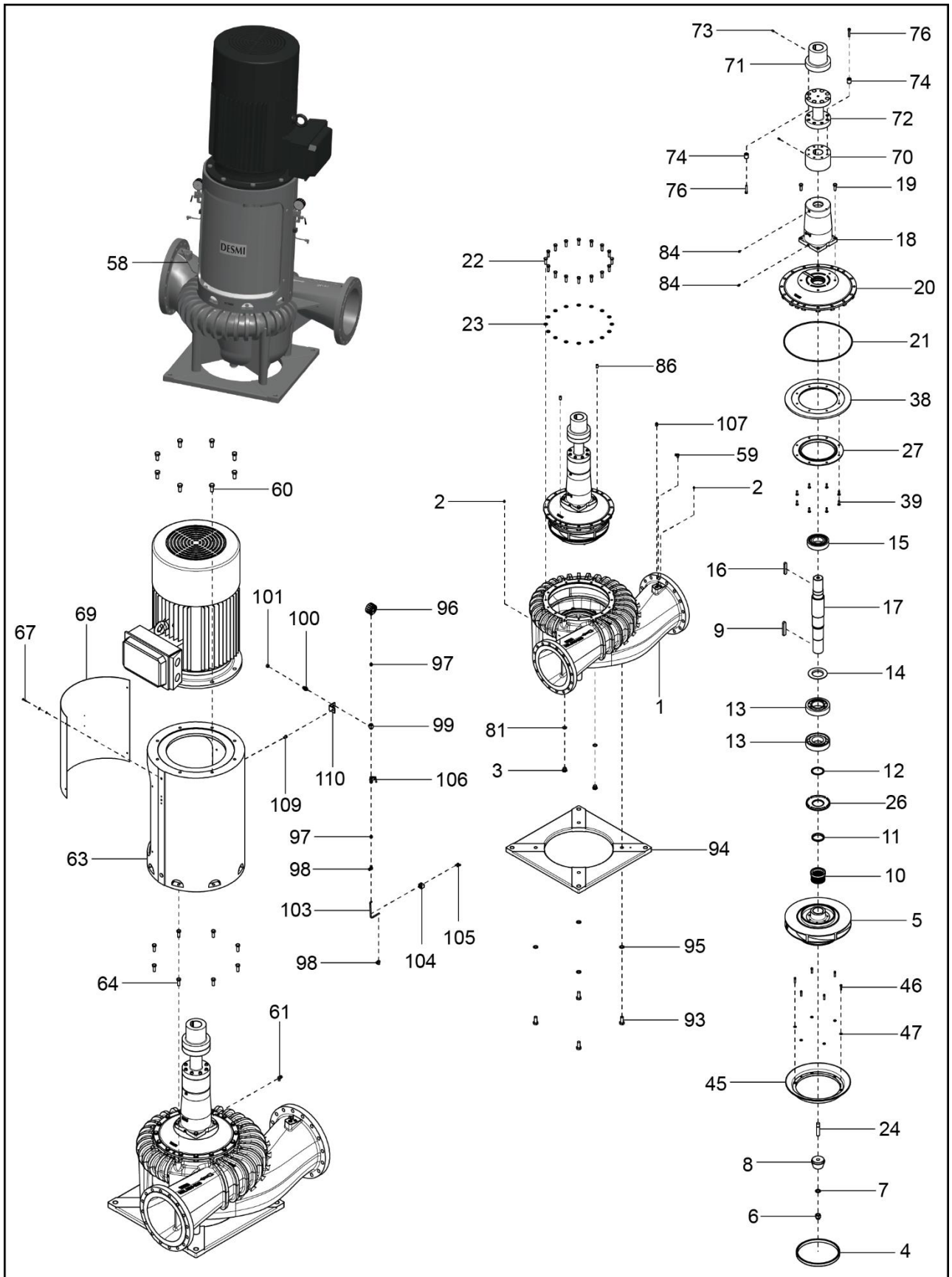

11.32. Spare parts list NSL350-525 -14 combination

Pos. No	Description	Pos. No	Description
1	Pump casing	59	Hexagon nipple
2	Pipe plug	60	Set screw
3	Pipe plug	61	Hexagon nipple
4	Sealing ring	63	Bracket
5	Impeller	64	Set screw
6	Cap nut	67	Set screw
7	Spring collar	69	Guard
8	Inlet cone	70	Coupling part pump
9	Sunk key	71	Coupling part motor
10	Mech. shaft seal	72	Spacer
11	Water deflector	73	Pointed screw
12	Ring lock	74	Coupling bush
13	Ball bearing	76	Allen screw
14	Grease valve ring	81	Sealing washer
15	Ball bearing	84	Lubricator nipple
16	Sunk key	86	Pointed screw
17	Shaft	93	Set screw
18	Bearing housing	94	Base plate
19	Set screw	95	Lock washer
20	Rear cover	96	Manometer
21	O-ring	97	Reducing nipple
22	Set screw	98	Hexagon nipple
23	Lock washer	99	T-piece
24	Stud	100	Bulkhead connection
26	Cover under bearing *	101	Screw cap
27	Sealing ring 2	103	Pipe
38	Guide plate	104	Pipe clamp
39	Counter sunk screw	105	Allen screw
45	Guide plate	106	Gauge valve
46	Allan screw	107	Pipe plug
47	Washer	109	Sets crew
58	Pipe	110	Manometer fitting

*) Option – See Appendix B

APPENDIX A

Check length from motor shaft end to motor flange being within ± 0.5 mm of the nominal length (like 60, 80, 110, 140 and 170 mm).

If the motor shaft is too short then fit a pointed screw glued into the motor shaft end to adjust the pump shaft to correct mounting position – in order to ensure correct build in length for the ELK shaft seal.

If the motor shaft is too long then it has to be machined / milled to nominal length.

It has to be checked if the shaft sealing have the correct length when mounted on the pump shaft as shown below. I.e. there shall always be 44.5 ± 0.5 mm from sliding surface on the seat to the end of the rotating part, on the sizes of ELK sealing used by DESMI. Please observe that the rotating part protrudes 2 mm beyond the shoulder on the pump shaft as shown below.

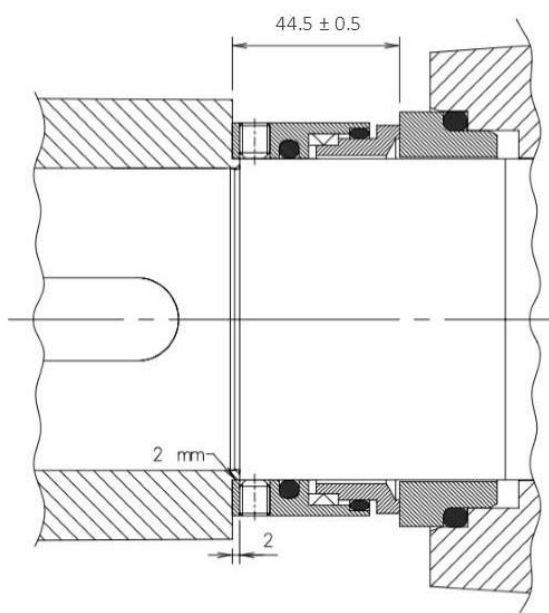

Figure 12-1: Nominal length

Also make sure that the electric motor is with locked bearing in the drive end – i.e. there must not be forced axial stroke of the electric motor.



NOTE: Never use mineral oil / fat as grease, as rubber parts as standard are in EPDM.



NOTE: *Never put grease on the sliding surfaces! They must be completely dry, dust-free and clean during the mounting procedure. Also any fingerprints shall be removed with alcohol or another suitable solvent.*



NOTE: *ELK shaft seals must be turned after installation. So O-rings, springs and sliding surfaces can slip into right placement before pressure testing. This is done by mounting the seal as described and later turn the shaft about 10 revolutions - with water in the pump - but without adding pressure. Then pressure test the pump as normally done.*

APPENDIX B

Assembly drawing of Lip seal kit in cover under bearing.

- The lip seal kit is optional.

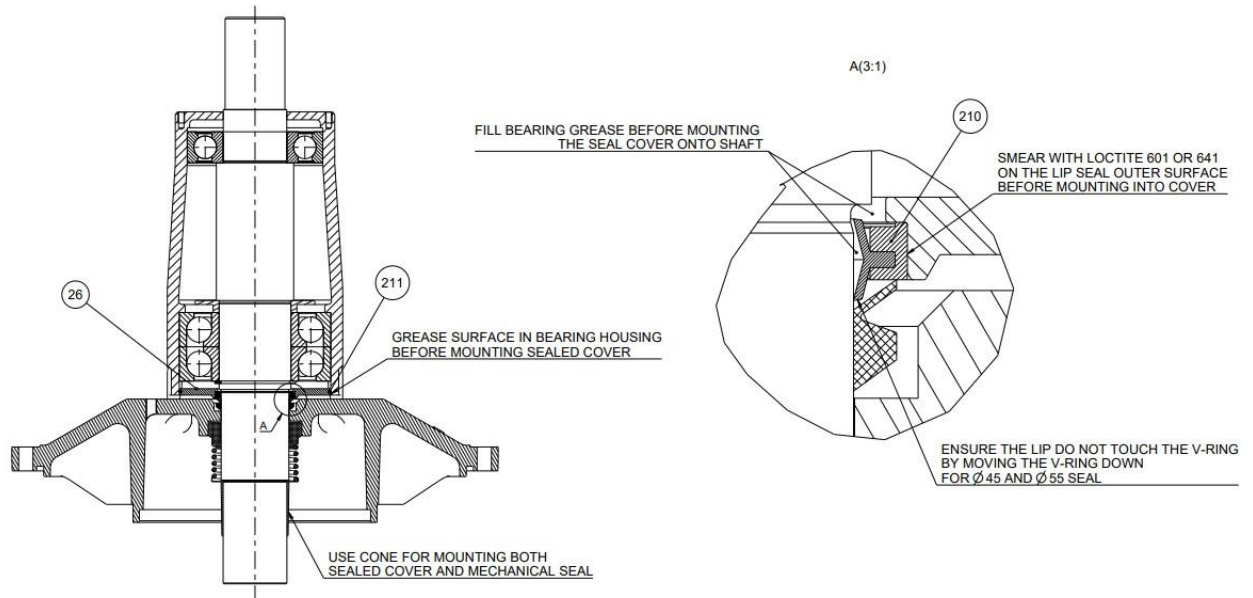

Figure 13-1 Lip seal kit in cover under bearing

SPARE PARTS LIST

Pos. No	Description
26	Cover under bearing
210	Lip Seal
211	O-ring